

USE OF ATTITUDE STICK FORCE CUES
TO IMPROVE VELOCITY CONTROL SYSTEM PERFORMANCE

by

LAWRENCE GEORGE ELBERFELD
Lieutenant Commander, United States Navy

BS, United States Naval Academy
(1964)

MSAE, United States Naval Postgraduate School
(1970)

Submitted in partial fulfillment of the requirements
for the degree of
ENGINEER IN AERONAUTICS AND ASTRONAUTICS
at the
Massachusetts Institute of Technology
January 1972

Signature of Author

Signature redacted

Department of Aeronautics and Astronautics
January 1972

Certified by

Signature redacted

Thesis Supervisor

Accepted by

Signature redacted

Chairman, Departmental Graduate Committee

Archives

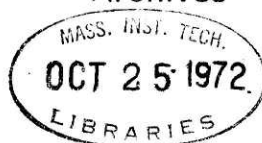

USE OF ATTITUDE STICK FORCE CUES
TO IMPROVE VELOCITY CONTROL SYSTEM PERFORMANCE

by

Lawrence George Elberfeld

Submitted to the Department of Aeronautics and Astronautics,
Massachusetts Institute of Technology, in January 1972, in
partial fulfillment of the requirements for the degree of
Engineer in Aeronautics and Astronautics.

ABSTRACT

This thesis investigates the feasibility of enhancing vehicle handling qualities in a helicopter velocity control system through the use of attitude feedback cues to the pilot. These cues are provided through a velocity controller whose stick force characteristics are programmed as a function of pitch attitude and pitch rate. The non-linear dynamics of such a control stick are linearized for system analysis and design. Preliminary analog verification is followed by system testing on a hybrid simulation of a tandem-rotor helicopter through a fixed-base cockpit installation to complete the pilot/vehicle interface. The results of various control tasks indicate that both handling quality opinion and mean-square performance criteria are considerably improved through the use of attitude-dependent force-feel characteristics in the controller.

Thesis Supervisor: H. P. Whitaker

Title: Professor of Aeronautics
and Astronautics

ACKNOWLEDGEMENTS

The author wishes to express his gratitude and appreciation to Professor H. P. Whitaker for his guidance and assistance as thesis supervisor.

Sincere thanks also go to the staff of the Tactical Systems Group of the M.I.T. Draper Laboratory for their advice and assistance. Particular acknowledgement is given to Mr. William C. Diniak, whose generous contributions of personal time, effort and technical expertise have been invaluable.

Additionally, I would like to thank Miss Jean Fennell for the expert typing and efficient handling of associated tasks in the final preparation of this document.

Finally, I wish to express my deepest appreciation to my wife, Gerrie, for her encouragement, patience and understanding throughout the completion of this work.

The research for this thesis was performed while serving on active duty with the U.S. Navy, under their sponsorship as a full-time graduate student at M.I.T. Simulator support was provided through the Tactical Systems Group in conjunction with DSR Project 54-33810, sponsored by the U.S. Army Aviation Materiel Laboratories under Contract DAAJ02-69-C-0038.

The presentation of this thesis does not constitute approval by the U.S. Navy, the U.S. Army or the Draper Laboratory of findings and conclusions contained herein. It is presented only for the exchange and stimulation of ideas.

TABLE OF CONTENTS

<u>Chapter</u>		<u>Page</u>
I	INTRODUCTION	9
II	SYSTEM DESCRIPTION AND INITIAL SPECIFICATIONS	12
	2.1 Introduction	12
	2.2 Horizontal X-Axis Velocity Control System	15
	2.3 Linearization of the Control Stick Dynamics	17
	2.4 Selection of System Parameters	20
III	ANALYSIS AND COMPENSATION DESIGN FOR THE RIGOROUS SYSTEM	27
	3.1 Introduction	27
	3.2 Incorporation of Actual Helicopter Dynamics	28
	3.3 System Analysis and Design	31
	3.4 Time Response of the Compensated System	36
IV	EXPERIMENTAL APPARATUS FOR THE FIXED-BASE TEST INSTALLATION	41
	4.1 Introduction	41
	4.2 Major Components	42
	4.3 The Experimental Two-Axis Controller	46

TABLE OF CONTENTS (CONT.)

<u>Chapter</u>		<u>Page</u>
V	SYSTEM PERFORMANCE ON THE FIXED-BASE TEST INSTALLATION	50
	5.1 Introduction	50
	5.2 Engineering Preparations for the Simulator Tests	50
	5.3 Attitude Control Tests	53
	5.4 Velocity Tracking Tests	58
	5.5 Related Tests	60
	5.6 Discussion of Results	62
VI	CONCLUSIONS AND RECOMMENDATIONS	68
	6.1 Conclusions	68
	6.2 Recommendations	69
<u>Appendices</u>		
A	THE INTERFACE WITH AN ACTIVE ENGINEERING GROUP	71
B	STATISTICAL ANALYSIS OF THE TEST RESULTS	74
<u>References</u>		78

LIST OF ILLUSTRATIONS

<u>Figure</u>	<u>Page</u>
2.1 Elements of a Manually Controlled System with Programmable Control Stick Characteristics	14
2.2 Elements of the XVCS with Programmable Control Stick Forces Proportional to Pitch Attitude	16
2.3 Conceptual Analog Representation of the Non-Linear System with Ideal PACS	23
2.4 Conceptual Analog Representation of the Linearized System with Ideal PACS	24
2.5 Time Response of the Idealized Systems	25
3.1 Block Diagram of Pitch Attitude Control System	28
3.2 Schematic Illustration of the Total System	30
3.3 Modified Block Diagram for Linear Analysis	31
3.4 Bode Gain Diagrams of the Linearized Systems	33
3.5 Nichols Chart for the Linearized Systems	34
3.6 Bode Diagrams of the Compensated and Model Systems	37
3.7 Time Response of the Linear System	39
3.8 Time Response of the Non-Linear System	40
4.1 Longitudinal Step Responses at (a) hover, (b) 40 knots, (c) 90 knots	43
4.2 Schematic Representation of the Test Installation	45
4.3 Schematic of the Longitudinal Axis of the Two-Axis Controller	48
5.1 Typical Pitch Errors for an Attitude Control Task	56

LIST OF TABLES

<u>Table</u>		<u>Page</u>
I	Longitudinal Characteristics, Experimental Two-Axis Controller	47
II	Results of Attitude Control Tasks	57
III	Results of Velocity Tracking Tasks	60
IV	Results Using Sub-Optimal Spring Stiffness	62

LIST OF SYMBOLS

<u>Symbol</u>	<u>Description</u>
c	Control Stick Damping Force Coefficient
CL	Closed Loop Transfer Function (Subscript)
E	Pitch Angle Measured from Trim Attitude
\dot{E}	Pitch Rate
F_E	Pseudo-Force Proportional to E
F_P	Pilot-Applied Force
$G_{(A,B)}$	Transfer Function Relating (A) to (B)
g	Acceleration of Gravity
K	Gain or Potentiometer Setting
k	Control Stick Spring Stiffness
OL	Open Loop Transfer Functions (Subscript)
p	Laplace Operator
PACS	Acronym for Pitch Attitude Control System
P_x	X-Displacement of Control Stick from Trim Position
$S_{(A,B)}$	Static Sensitivity Relating (A) to (B)
S_k	Static Sensitivity Relating Pitch Angle to Control Stick Stiffness
V_x	X-Velocity
XVCS	Acronym for X-Velocity Control System
δ_ϵ	Longitudinal Pitch Actuator Displacement
ϵ	Error Quantity (Subscript)
τ	Time Constant

CHAPTER I

INTRODUCTION

In recent years, as the helicopter and other V/STOL aircraft have moved to assume an increasingly important role in both the military and domestic environments, the systems technology relating to such vehicles has, of necessity, shown proportionate advances in sophistication, versatility and reliability. Considerable research and development has been undertaken in the control of these vehicles, and one of the more current evolutions is the direct velocity controller for helicopters, whereby control stick displacement commands vehicle velocity rather than cyclic pitch. Related studies have indicated that not only is such a fly-by-wire flight control system a requisite step in fully exploiting the potential of VTOL aircraft¹, but that encouraging improvement in flight path control has accompanied the use of such a system².

While pitching motion is "one step removed" from the pilot's direct control in a longitudinal velocity control system, it is still a requisite action for translational velocity changes in a helicopter, since the rotor thrust vector must be reoriented. In addition to leaving the realm of direct control of vehicle attitude, the pilot has also lost one of his key

cues to that attitude, in that control stick force and displacement are now correlated with velocity. In hopes of eliminating this deficiency and concurrently enhancing the handling qualities of the helicopter, the present study will investigate the use of a velocity controller whose displacement will continue to command velocity, but whose stick-force characteristics can be programmed as a function of any measurable signal in general, and some combination of stick displacement and vehicle attitude (and their derivatives) in particular.

Varying the spring stiffness of the control stick as a function of the pitch angle of the vehicle results in nonlinear stick dynamics (products of pitch angles and stick displacements). When coupled to the longitudinal response mode of the helicopter, this yields a highly complex system. Hence, the initial analysis will deal with a simplified helicopter representation (mass and inertia) in order to investigate feasible linearization schemes for the control stick dynamics.

This analysis, as well as a description of the total system, is presented in the following chapter. Chapter III reflects the incorporation of actual helicopter dynamics, the ensuing problems, and the design and optimization of compensation to restore system performance to a desirable level.

The fourth chapter describes the experimental test apparatus-- the fixed-base cockpit installation, the hybrid helicopter simulation, and the programmable control stick-- employed as a test vehicle. Chapter V deals with the preparations for, the conduct of, and the results of several independent tests of system performance, both with and without the programmable control stick characteristics. The final chapter presents the conclusions drawn from this work and recommendations for future study.

Not evident in the text of this thesis, but a dominant influence on its ultimate outcome, was the integration of this work into the schedule of an active engineering group. The considerations involved in the liaison between student research and the priorities of a group project was enlightening and, at times, frustrating. This interface is discussed in greater detail in Appendix A.

CHAPTER II

SYSTEM DESCRIPTION AND INITIAL SPECIFICATIONS

2.1 Introduction

The material presented in this chapter is designed to acquaint the reader with the purpose of velocity control systems and the considerations involved in applying pitch-related force feedback to the control stick providing the inputs to such a system. Several simplifying assumptions will be made at this time in order to attack the problem on a manageable level, but in subsequent chapters these constraints will be relaxed.

While it is self-evident that helicopters, through their low-speed and hovering capability, offer a distinct advantage over conventional aircraft for various civilian and military applications, this advantage has not always been exploited to the fullest. The prime reason for such shortcomings lies in the inherently poor handling qualities of helicopters, particularly in the low-speed (including hover) flight regime. The problem is further complicated by the variable nature of vehicle dynamics with changing flight conditions.

Longitudinal velocity control systems, which include pitch attitude control and altitude control subsystems, have been developed to free the pilot from portions of the stabilization tasks in the aircraft, thereby allowing him to devote a greater percentage of his time to more basic missions, such as flight

path control or the performance of required maneuvers. If ground speed is the controlled quantity, as is usually the case for low-speed flight, it is evident that a precise hover can be maintained by merely positioning the control stick in the null position. And if vertical velocity is also directly controlled, an instrument approach glide slope can conceptually be intercepted and tracked more readily than performing the approach with conventional attitude control maneuvering.

Using a programmable control stick rather than one with conventional spring stiffness and damping has shown to be effective in improving handling qualities in several experiments.³ A functional diagram of the basic elements involved in such a controller is shown in Figure 2.1, where the input errors to the pilot are either displayed directly or deduced by the pilot by comparing desired and actual outputs of the system. In that the control stick displacement must correspond directly to the commanded velocity, it cannot also provide attitude cues. But the control stick force is under no such constraint, and is available as a free parameter to the designer. By providing a perceptible attitude cue to the pilot through stick force, his neuromuscular mechanisms may interpret this cue in a profitable way so as to modify his performance and hopefully improve the overall handling qualities of the vehicle.

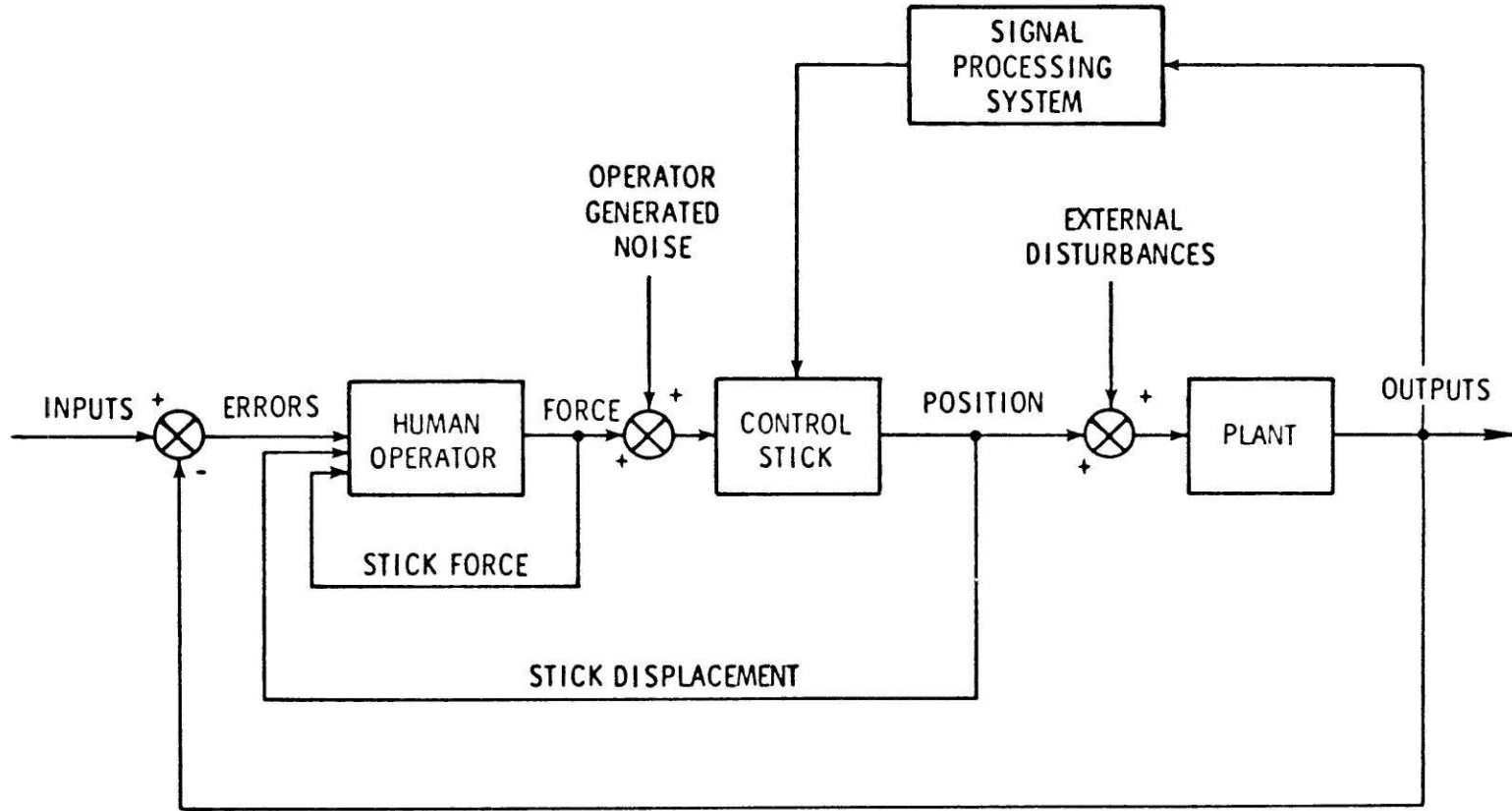

ELEMENTS OF A MANUALLY CONTROLLED SYSTEM
WITH PROGRAMMABLE CONTROL STICK CHARACTERISTICS

FIGURE 2.1

2.2 Horizontal X-Axis Velocity Control System

The horizontal x-axis velocity control system (XVCS) to be studied is commanded directly by control stick displacements. Figure 2.2 shows the basic elements of the system under consideration, where PACS represents the Pitch Attitude Control System. The most significant simplification to be made at this time is the treatment of the helicopter as a pure mass and inertia. This means the PACS will be considered unity, and the helicopter pitch angle (E) is identically equal to the commanded pitch angle (E_c) at all times. Additionally, the helicopter will be treated as an integrator with respect to achieving its forward velocity (V_x) from pitch angle. That is,

$$V_x = - \frac{g}{p} E \quad (2.2.1)$$

Hence,

$$G_{OL}(V_{x_c}, V_x) = \frac{-g S(v, E_c)}{p} \quad (2.2.2)$$

and,

$$G_{CL}(V_{x_c}, V_x) = \frac{1}{1 + \tau_v p} \quad (2.2.3)$$

where

$$\tau_v \equiv - \frac{1}{g S(v, E_c)} \quad (2.2.4)$$

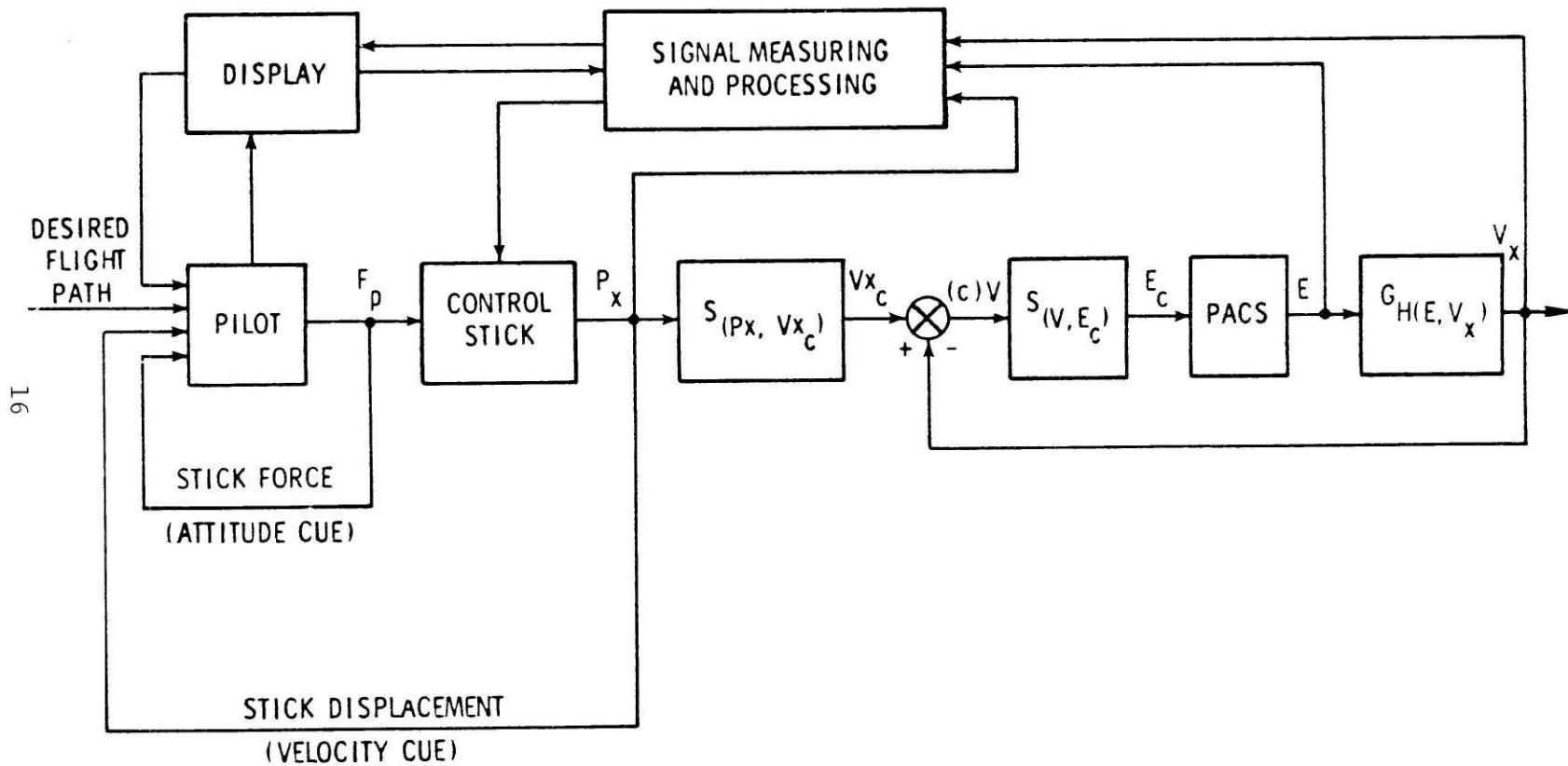

ELEMENTS OF THE XVCS WITH PROGRAMMABLE CONTROL STICK FORCES
PROPORTIONAL TO PITCH ATTITUDE

FIGURE 2.2

Note that $S_{(V, E_c)}$ is a negative quantity since, by convention, forward velocity is positive while nose-down pitch is negative. Assigning the convention that forward control stick displacement (P_x) is positive, the sensitivity $S_{(P_x, V_{x_c})}$ is positive. This then gives a positive gain system from stick displacement to x-velocity:

$$G_{(P_x, V_x)} = \frac{S_{(P_x, V_{x_c})}}{1 + \tau_v p} \quad (2.2.5)$$

This portion of the system, under the simplifying assumptions stated, behaves as a simple gain and lag.

2.3 Linearization of the Control Stick Dynamics

Beginning with the basic equation of motion for a displaced control stick with negligible inertia forces ,

$$c\dot{P}_x + kP_x = F_p \quad (2.3.1)$$

where c = damping force coefficient

k = force centering gradient

F_p = pilot-applied force.

To incorporate pitch information, the force centering gradient, or spring "stiffness", is set equal to some steady-state value plus a signal proportional to the pitch angle:

$$c\dot{P}_x + (k_o + S_k E)P_x = F_p \quad (2.3.2)$$

where S_k = static sensitivity relating pitch angle to spring stiffness.

The non-linearity in the problem, EP_x , is now evident. A more subtle problem concerns the net sign of this product. A forward (positive) force by the pilot will substantially result in a positive stick displacement and a negative pitch angle. With S_k negative, this portion of the stick force gradient is stabilizing. But for a similar negative force by the pilot, both P_x and E will be opposite in sense, but their product will remain negative, thereby contributing a destabilizing effect. This situation can be remedied by considering the absolute value of one of the signals. The most frequently encountered commands from the pilot involve essentially one-sided stick displacements. The pitch attitude, however, might experience a sign reversal during a maneuver to counter any undesired velocity build-up. If only the magnitude of the pitch angle were considered, the pilot would be provided with an erroneous force cue as the vehicle pitched through its trim position. This reason, coupled with the fact that the desired stick-force cue should correlate well with the pitch attitude, led to the decision to use, instead, $E|P_x|$ for the non-linear term. This decision was further substantiated by analog simulation of the system with numerous force inputs. Pitch reversals occurred frequently if the control stick returned to or near its trim position, but only on rare occasions did the control stick actually pass through its trim position, which would cause a sign

change in P_x . This absolute value requirement is circumvented by the linearization process outlined in subsequent pages, but it is imperative that the treatment described above be applied to any analysis or actual use of the "real" (non-linear) system.

To linearize, begin with Equation (2.3.2), and let the coupled terms be replaced by

$$E = E_0 + \Delta E \quad (2.3.3)$$

$$P_x = P_{x_0} + \Delta P_x$$

where E_0 and P_{x_0} are constant nominal values of pitch and control stick displacement which will provide linear system performance matching non-linear performance as closely as possible in the maneuvering region of interest. The resulting equation, dropping the Δ 's for notational simplicity, is:

$$\begin{aligned} c\dot{P}_x + k_0 P_x + k_0 P_{x_0} + S_k E_0 P_{x_0} \\ + (S_k E_0 P_x + S_k P_{x_0} E + S_k P_x E) = F_p \end{aligned} \quad (2.3.4)$$

Trimming out the fixed term forces and representing the three terms in parentheses by only the first two such terms, the equation is now linear:

$$c\dot{P}_x + (k_0 + S_k E_0) P_x + (S_k P_{x_0}) E = F_p \quad (2.3.5)$$

While this method of linearization was found suitable for

the problem under study, its general applicability is doubtful. The selection of fixed values for E_0 and P_{x_0} is, in effect, incorporating the absolute value requirements of the non-linear system, as discussed earlier. For a problem in which the signs of the coupled terms are not directly correlated, it is questionable if nominal values of these parameters could be found which would provide acceptable response characteristics of the linearized system. There appears no reason, however, why this linearization scheme would not be generally applicable to problems in which a sign correlation existed similar to that under study or if the coupled variables did not change sign.

2.4 Selection of System Parameters

Two sets of parameters must be determined at this stage, the first being the system parameters and the second being the nominal values of E_0 and P_{x_0} to satisfy the linearization of the previous section. The system parameters, in addition to meeting certain physical constraints, should also provide desirable, or at least acceptable, vehicle handling qualities. But these handling qualities are highly subjective, being based primarily on pilot opinion. Cooper⁴ has had the most notable success in attempting to quantify pilot opinion, but his technique is "after the fact", and of little help to the designer. The Armed Forces has published a valuable design aid in the form of a document⁵ specifying various flying qualities, flight

envelopes, flight phases, failure modes, and other related criteria for conventional military aircraft. A similar publication is being prepared for V/STOL aircraft (including helicopters), but is not yet available.

This leaves the selection of certain system parameters in the subjective realm, particularly those relating to control stick dynamics. Selecting a particular vehicle and control system will establish a number of the parameters in question. Due to the anticipated availability of a fixed-base hybrid simulation of the CH-46C tandem-rotor helicopter, representative characteristics of that simulation were employed. These were:

$$S_{(P_x, V_{x_c})} = 33.8 \frac{\text{feet/second}}{\text{inch}}$$

$$S_{(V, E_c)} = -0.860 \frac{\text{degree}}{\text{feet/second}} = -0.015 \frac{\text{radian}}{\text{feet/second}} .$$

Using an armrest-mounted controller in lieu of the conventional floor-mounted control stick, test pilots in the actual helicopter determined that vehicle handling qualities were best for non-programmable stick dynamics of

$$c = \text{damping force coefficient} = 0.778 \frac{\text{pound}}{\text{inch/second}}$$

$$k = \text{force centering gradient} = 0.973 \frac{\text{pound}}{\text{inch}} .$$

The damping force coefficient will be retained at this nominal value. Noting that Jamieson³ found better overall performance

with higher than nominal "stiffness" in the low-speed range, suitable manipulator characteristics were ultimately chosen to be

$$k_o = 0.25 \frac{\text{pound}}{\text{inch}}$$

$$S_k = -0.20 \frac{\text{pound/inch}}{\text{degree}} = -11.46 \frac{\text{pounds/inch}}{\text{radian}} .$$

These values represent the subjective "optimum" based on analog simulation of the system with various values of k_o and S_k .

This simulation, shown conceptually in Figure 2.3, in which scaling and certain sign changes are not explicitly shown, was also used in the selection of E_o and P_{x_o} . Numerous test inputs ($-F_p/c$) were applied to the system and the resultant pitch angles, stick displacements and time integrals were observed, recorded and processed to determine preliminary values of E_o and P_{x_o} . These values were then used in a simulation of the linearized system (Figure 2.4), which was run simultaneously with the non-linear system under identical inputs to allow accurate and detailed comparison. Only slight modifications of the preliminary values were needed to provide a reasonably close approximation of the non-linear system by the linearized system. Figure 2.5 shows representative results of a typical pitching maneuver for the selected nominal values of

$$E_o = -5.55 \text{ degrees} = -0.097 \text{ radian}$$

$$P_{x_o} = 0.38 \text{ inch.}$$

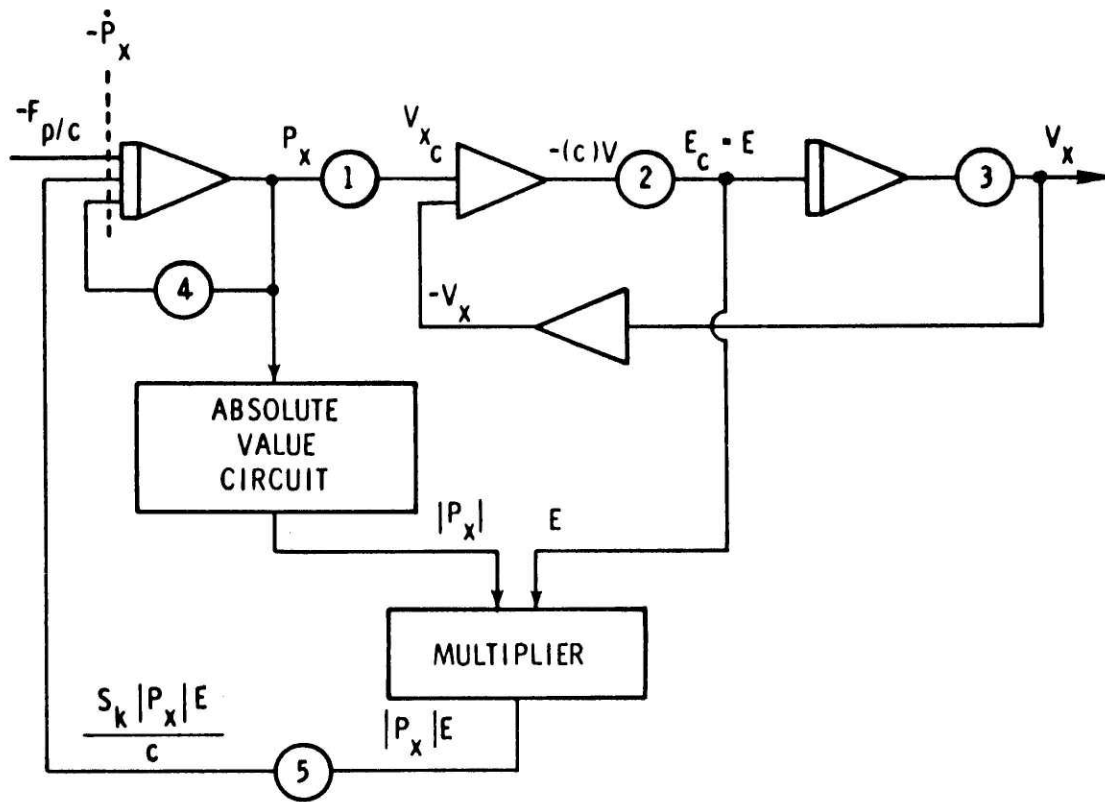

$$\dot{-P}_x = -\frac{F}{c} + \frac{k_0 P_x}{c} + \frac{S_k |P_x| E}{c}$$

GAIN REQUIREMENTS

- ① - $S_{(P_x, V_{x_c})}$
- ② - $S_{(V, E_c)}$
- ③ - g
- ④ - k_0/c
- ⑤ - S_k/c

CONCEPTUAL ANALOG REPRESENTATION OF THE
NON-LINEAR SYSTEM WITH IDEAL PACS

FIGURE 2.3

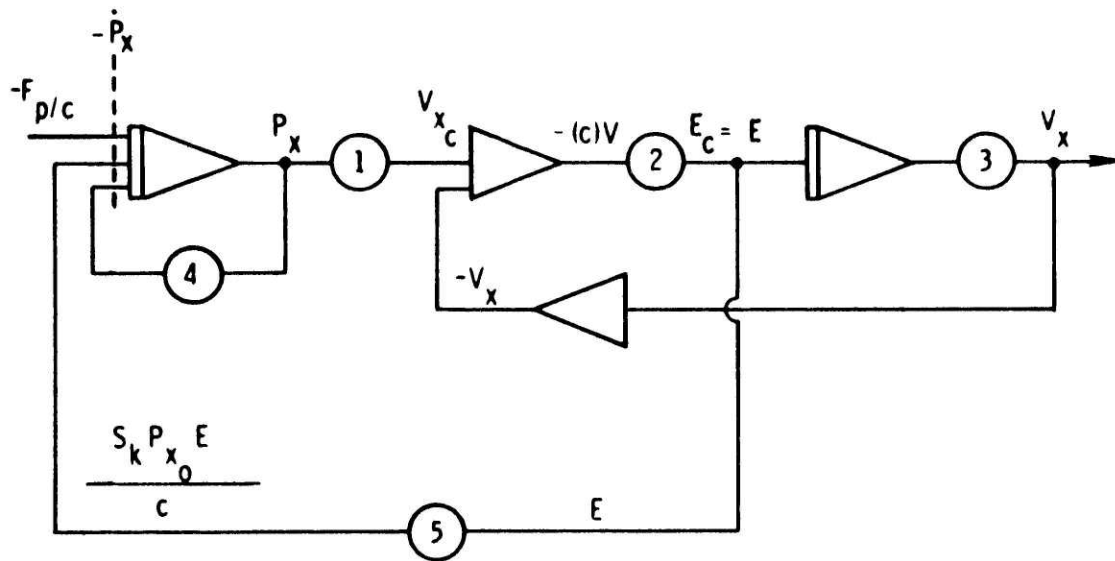

$$-\dot{P}_x = -\frac{F_p}{c} + \frac{k_o + S_k E_o}{c} P_x + \frac{S_k P_{x_0}}{c} E$$

GAIN REQUIREMENTS

- ① = $S_{(P_x, V_{x_c})}$
- ② = $S_{(V, E_c)}$
- ③ = g
- ④ = $(k_o + S_k E_o) / c$
- ⑤ = $(S_k P_{x_0}) / c$

CONCEPTUAL ANALOG REPRESENTATION
OF THE LINEARIZED SYSTEM WITH IDEAL PACS
FIGURE 2.4

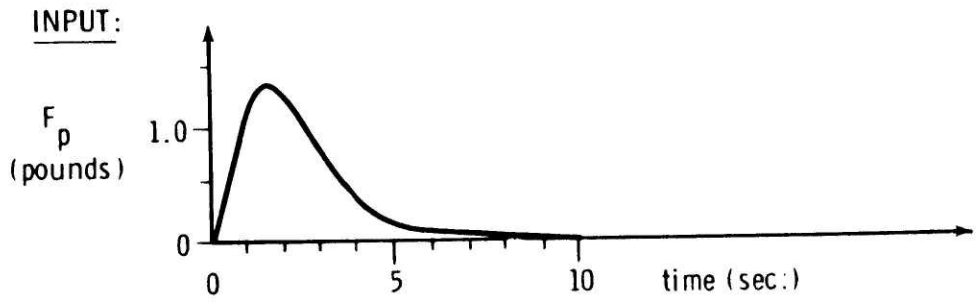

— Linear System
 - - - Non-linear System

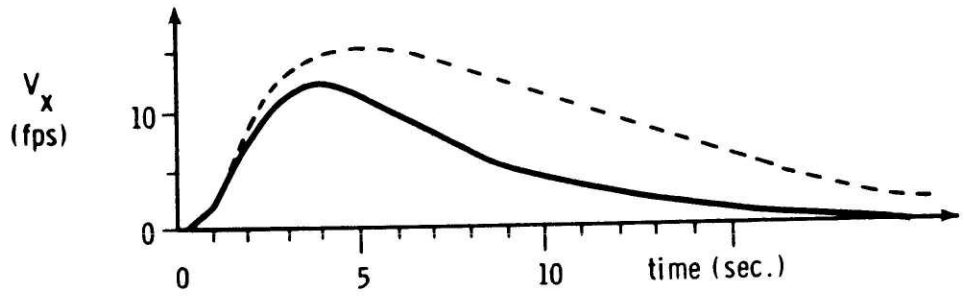
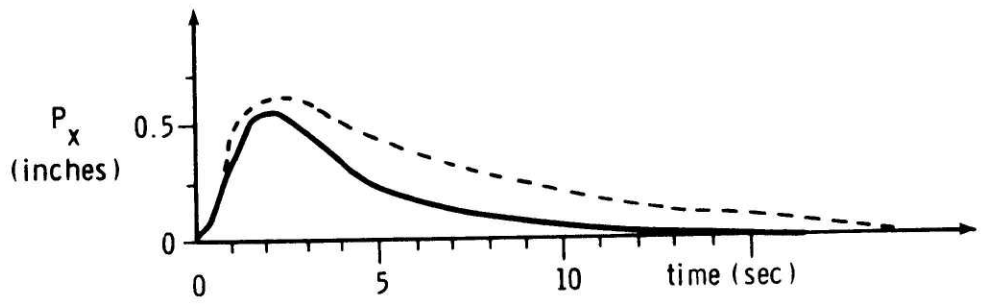
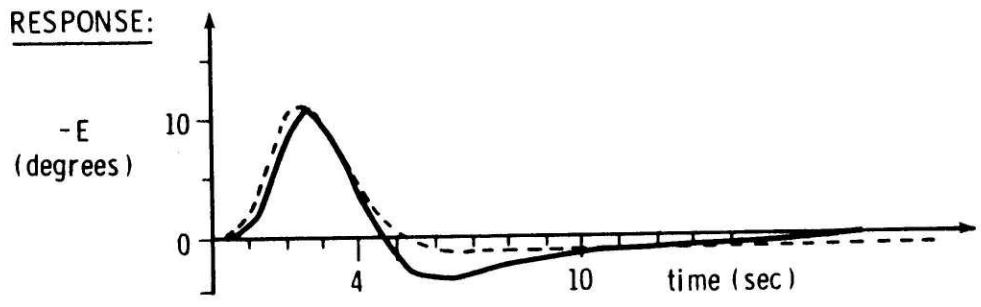

TIME RESPONSE OF THE IDEALIZED SYSTEMS
 FIGURE 2.5

In this figure the pitch axis is drawn with negative (nose-down) pitch angles up, in order to show more clearly the correlation between attitude and pilot force. The phenomenon described in Section 2.3 is clearly evident for this particular maneuver, as the vehicle pitches up slightly after its initial nose-down response, in order to return to the trim velocity. The control stick, however, does not pass through its trim position.

In selecting these nominal values, primary emphasis was placed on matching responses for typical pitching maneuvers a pilot might desire for visual observation purposes. This criterion was weighted most heavily for two reasons. It was felt that pitch feedback cues would be especially helpful if the pilot were trying to command a pitch maneuver. Also, response matching under such transitory conditions was generally more difficult to satisfy than conditions resulting from more standard test inputs, such as steps or ramps. As a final verification, constant control stick displacements were applied, as in commanding a new velocity, and the resultant open loop pitch and stick force signals were observed and found to provide the desired correlation, both in the linear and non-linear cases.

CHAPTER III

ANALYSIS AND COMPENSATION DESIGN FOR THE RIGOROUS SYSTEM

3.1 Introduction

Having achieved acceptable results from the simplified systems described in the previous chapter, this chapter will deal with the incorporation of actual helicopter performance data. It will also discuss the difficulties encountered as a result of these more realistic dynamics, and the adjustments that were made to return the performance of the system to a desirable level.

The most significant assumption made in Chapter II was modelling the Pitch Attitude Control System (PACS) as a unity transfer function. In reality, the PACS is of relatively high-order after compensation of undesirable response modes are included in the system. Typical PACS performance functions for the CH-46C helicopter under study were found by Todd⁶ to be eighth- to tenth-order systems, depending on the flight conditions and the amount of pole-zero cancellation possible. An appropriate ninth-order system was patched into the area representing the PACS in the analog simulation, as shown in Figures 2.3 and 2.4. The commanded pitch angle (E_c) is the input to this PACS, the actual pitch angle (E) is the output, and the closed-loop static sensitivity is unity.

The second major assumption of Chapter II was relaxed by modifying the idealized relationship between pitch angle and forward velocity. The pure integration was replaced by a more appropriate third-order transfer function, as determined by the vehicle stability and control derivatives.

3.2 Incorporation of Actual Helicopter Dynamics

The PACS incorporated into the complete system is shown in block diagram form in Figure 3.1 .

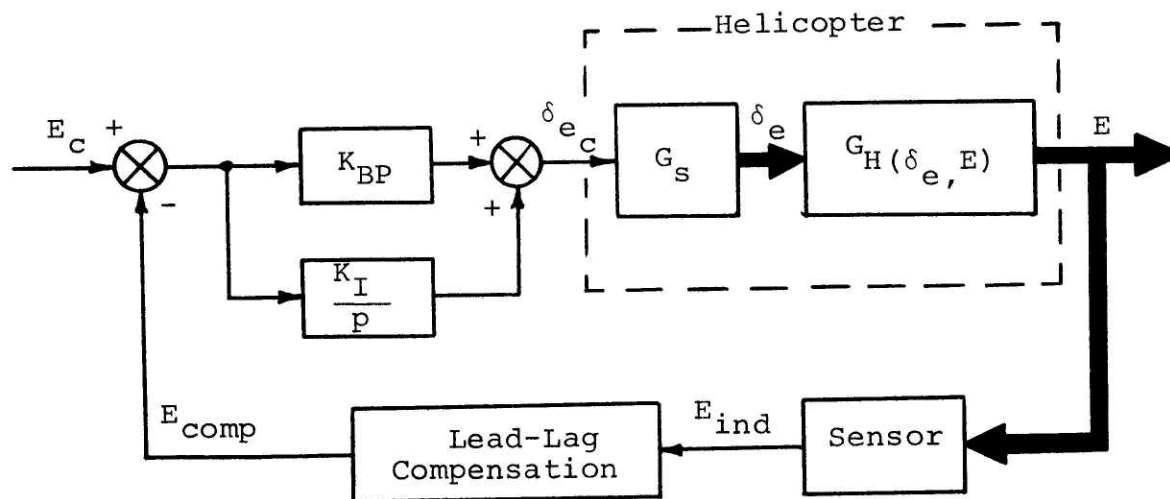

Figure 3.1 Block Diagram of Pitch Attitude Control System

In this figure,

δ_e = longitudinal actuator displacement (inches)

K_{BP} = bypass gain = 0.178 inch/degree

K_I = integral path gain = $0.050 \frac{\text{inch/second}}{\text{degree}}$
 G_{FB} = feedback compensation (lead-lag)
 G_s = servo and rotor transfer function.

In transfer function form,

$$G_{FB} = \left[\frac{7(0.05)p+1}{(0.05)p+1} \right]^2 \quad (3.2.1)$$

$$G_s = \frac{217.36}{(p+14.3)(p+15.2)} \quad (3.2.2)$$

$$G_{H(\delta_e, E)} = \frac{17.953(p+0.0206)(p+0.2915)}{(p+0.2654)(p+0.8669)[p-0.0972+j0.4175]} \frac{\text{degree}}{\text{inch}} \quad (3.2.3)$$

All system parameters and transfer functions are now realistically defined, and the complete linear and non-linear systems, as shown in Figure 3.2, were ready for testing. When test inputs similar to those of the previous chapter were applied to the total system, the pitch response was stable, but objectionably oscillatory. This completely unacceptable response was evident in both the non-linear and linear systems to approximately the same extent. Analysis of the linear system to determine adequate compensation for the non-linear system was therefore deemed feasible. By appropriate block diagram manipulation, the system can be represented as a unity feedback system in tandem with a pure gain, as shown in Figure 3.3 .

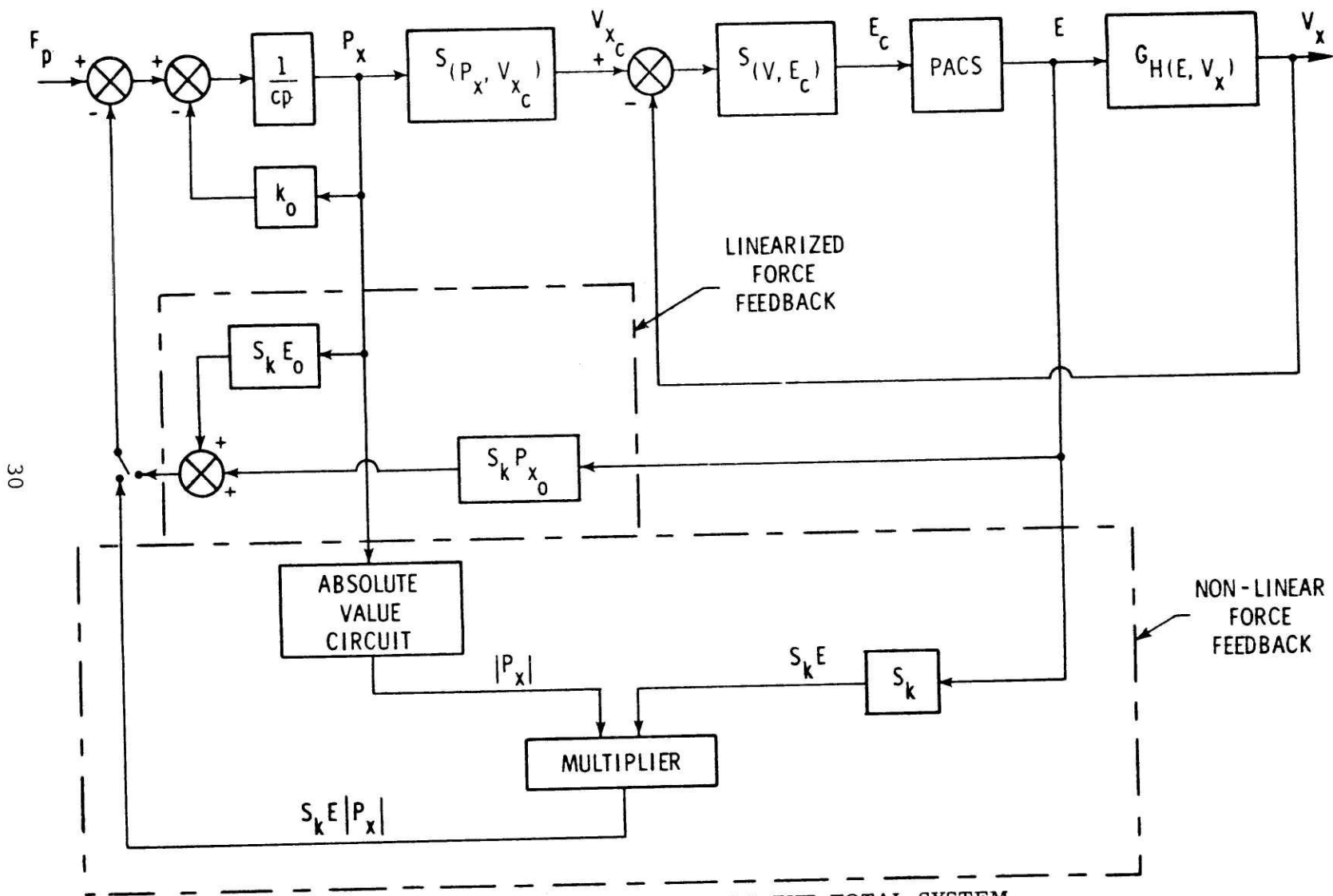

30

SCHMATIC ILLUSTRATION OF THE TOTAL SYSTEM
 FIGURE 3.2

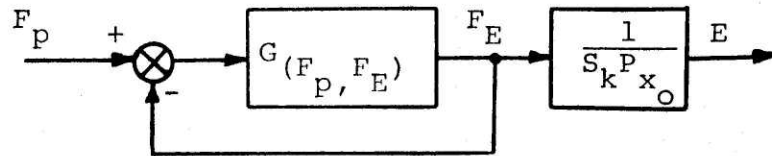

Figure 3.3 Modified Block Diagram for Linear Analysis

The quantity F_E is a force directly proportional to the pitch angle, E . Hence, the pitch response is proportional to the pseudo-force, F_E . For this reason, the analysis and design process will consider the transfer function $G_{(F_p, F_E)}$ as well as $G_{(F_p, E)}$, both of which embody the PACS, the XVCS, and portions of the control stick dynamics.

3.3 Systems Analysis and Design

To determine the cause of and the possible remedy for the undesirable oscillations described above, a frequency-domain analysis of the linear system was conducted. In closed-loop form, the PACS was determined to be:

$$\text{PACS} = \frac{34040 (p+0.0206) (p+0.2809) (p+0.2915) (p+20.0)^2}{(p+0.01757) (p+0.2691) (p+0.3824) [p+0.9083 \pm j1.442]}$$

$$\times \frac{1}{[p+7.410 \pm j7.629] [p+26.57 \pm j9.127]}$$

(3.3.1)

Closing the velocity loop around this PACS and including the portion of the system preceding the XVCS, with the parameter

values given in Chapter II, the open-loop transfer function for Figure 3.3 was found to be:

$$G_{OL}(F_p, F_E) = \frac{11168(p+0.0206)(p+0.2809)(p+0.2915)(p+20.0)^2}{(p+0.9562)(p+1.735)[p+0.2565 \pm j0.0073]} \times \frac{1}{[p+0.4973 \pm j1.315][p+7.423 \pm j7.644][p+26.57 \pm j9.129]} \quad (3.3.2)$$

The Bode diagram for the close-loop response from pilot force to vehicle pitch attitude is shown in Figure 3.4. For reference, the closed-loop frequency response for the ideal (PACS = 1) system is also plotted. These transfer functions, as can be seen from Figure 3.3, are given simply by

$$G_{CL}(F_p, E) = \frac{1}{S_k P_{x_0}} G_{CL}(F_p, F_E) \quad (3.3.3)$$

That is, only a shift in the magnitude axis is needed to convert a plot of $G_{CL}(F_p, F_E)$ to one of $G_{CL}(F_p, E)$.

From Figure 3.4 it is dramatically evident that the uniform response over the bandwidth of interest in the ideal case is sorely lacking in the more rigorously-defined system. To investigate the problem further and to determine what type of compensation was needed, a Nichols Chart was employed (Figure 3.5). This substantiated the fact that the gain of the system was acceptable, yet showed clearly that considerable phase lead was necessary in order to juxtapose the characteristics of the troublesome system with the more desirable traits of the ideal system.

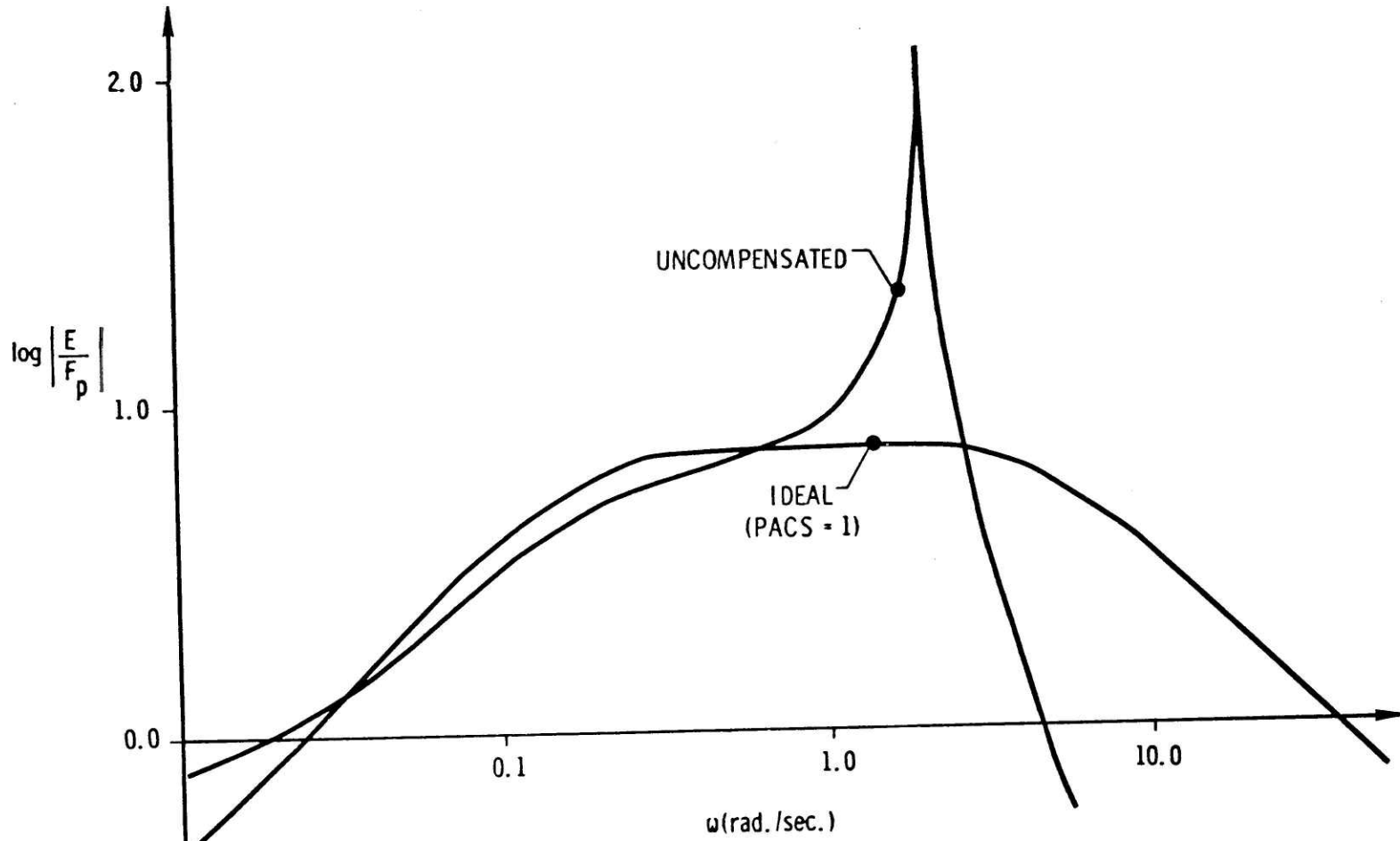

BODE GAIN DIAGRAMS OF THE LINEARIZED SYSTEMS
FIGURE 3.4

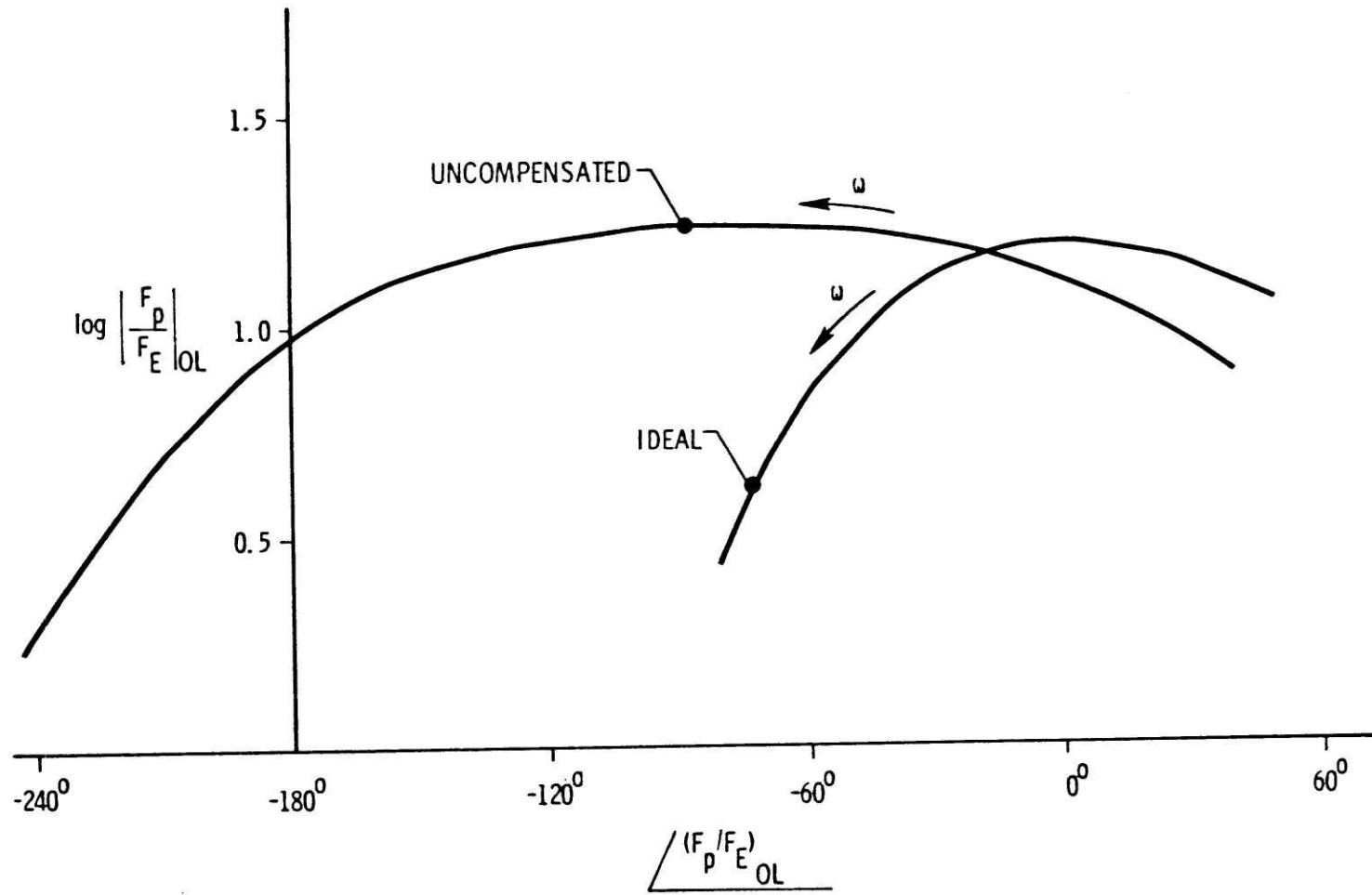

NICHOLS CHART FOR THE LINEARIZED SYSTEMS

FIGURE 3.5

Since pitch rate is a readily available signal, both in the actual helicopter and in the simulations, rate compensation was selected as the means of providing the system with lead. This will result in providing force-feel characteristics to the pilot which are proportional to pitch rate as well as pitch attitude. But such a cue is justified by Oakes⁷, who found pitch rate to be a meaningful feedback quantity to the pilot in helicopter feel-augmentation systems. The unity feedback path of Figure 3.3 must be modified accordingly, to include this compensation:

$$G_{\text{comp}} = 1 + \tau_c p \quad (3.3.4)$$

To find an appropriate value of τ_c , a design procedure developed by Rediess⁸ and modified by Palsson⁹ was employed. This technique, using an iterative digital computer program, determines the optimum value of a selected design parameter in the system under study. This value provides the subject system with response characteristics most nearly duplicating those of a specified model system. In this case, the ideal system was used as the model, and τ_c was the free design parameter. Considerable improvement in the system response was achieved with the rate compensation selected by the design program ($\tau_c = 0.532$), but further refinement still seemed possible.

In view of the fact that this synthesis procedure will

treat more than one free parameter, the static sensitivity relating the pitch quantities to spring stiffness (S_k) was also considered. This parameter was added to the optimization scheme for several reasons. As outlined in Chapter II, S_k was selected somewhat subjectively, and was applicable to the linear and non-linear systems when the PACS was idealized. With actual helicopter dynamics incorporated, a different value of S_k would appear in order. Further, S_k is now working on a different signal ($E + \tau_c \dot{E}$ vice E alone). And finally, S_k is one of the main keys to the successful operation of the system since it plays an important role in fixing the magnitude of the force feedback cue to the pilot.

The design process ultimately led to the optimum parameter values of:

$$S_k = -0.0664 \frac{\text{pound/inch}}{\text{degree}} = -3.80 \frac{\text{pound/inch}}{\text{radian}}$$

$$\tau_c = 1.41 \text{ second.}$$

Modifying the system to reflect these new values, the closed-loop Bode diagram was altered considerably (Figure 3.6). A very close match with the gain of the model system was attained, and the phase angles were within acceptable limits, except at frequencies outside the bandwidth of interest.

3.4 Time Response of the Compensated System

Incorporating these new parameter values into the analog

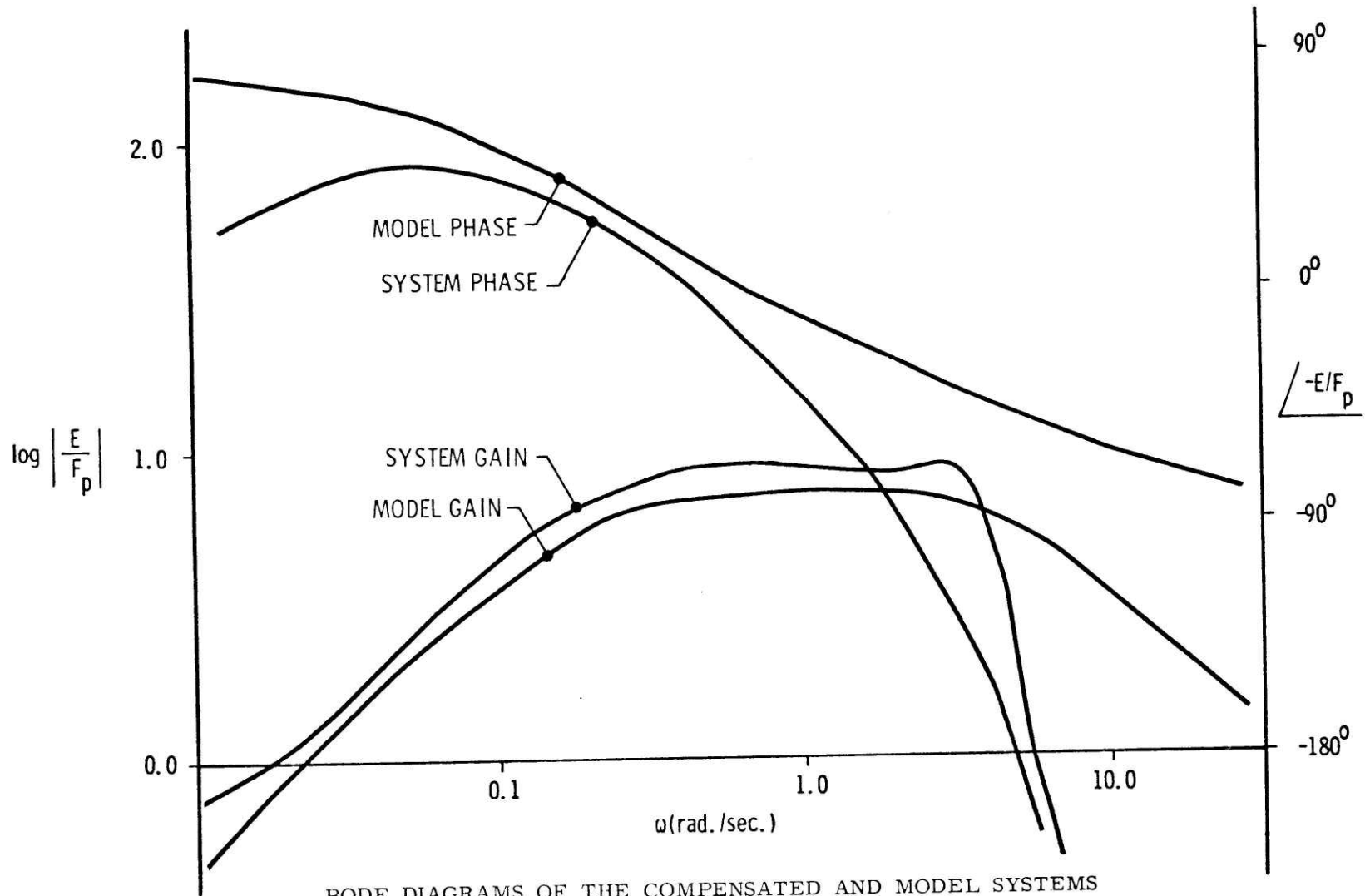

BODE DIAGRAMS OF THE COMPENSATED AND MODEL SYSTEMS
FIGURE 3.6

simulation, the compensated system was ready for final testing. As before, the primary inputs were programmed forces applied by the pilot (F_p). These were in the form of steps, ramps, truncated ramps, and shaped pulses. Some open-loop testing with step inputs of control stick displacement was also undertaken to verify the correlation between the force feedback and the vehicle's pitch attitude and pitch rate. All such tests resulted in well-damped time responses which were qualitatively as predicted and anticipated.

Shaped pulses of pilot-force provided the most troublesome compensation task, in that their uncompensated response was the most oscillatory. Applying the specified pitch rate compensation, however, resulted in a substantial improvement in system performance. The time responses to a typical test input for both the linear and non-linear systems are shown in Figures 3.7 and 3.8, respectively. In each case, the responses before and after compensation are plotted.

The system was now operating satisfactorily for all inputs, but the limited capability of the analog simulation (48 operational amplifiers, including 16 integrators) had been reached. Further, several artificialities of the simulation and test procedure, as outlined in the succeeding chapter, could not be circumvented. It was clearly time to move to the next phase of this work--system testing on a sophisticated simulation of an actual helicopter.

INPUT:

F_p
(pounds)

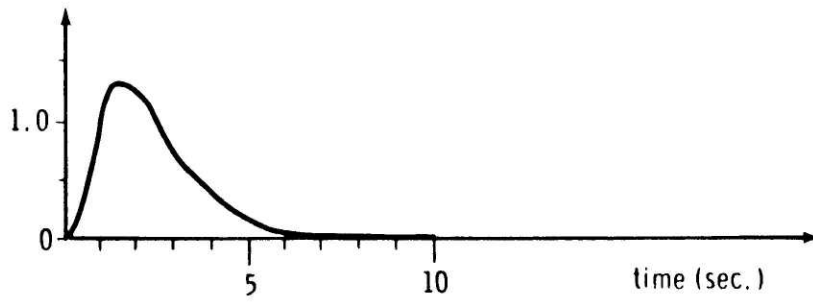

RESPONSE:

$-E$
(degrees)

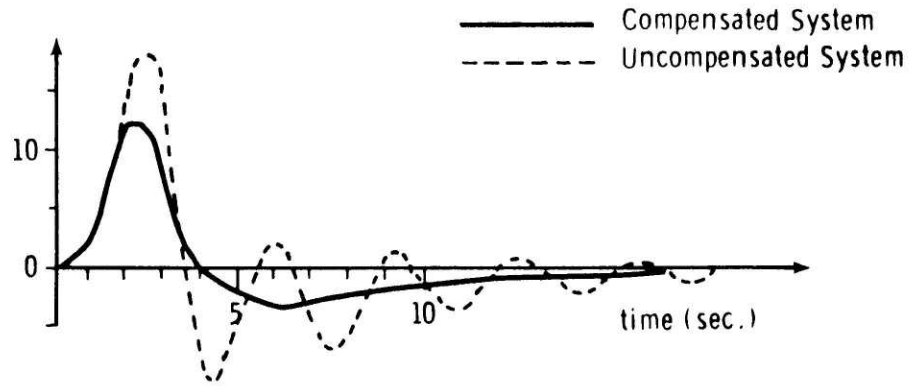

P_x
(inches)

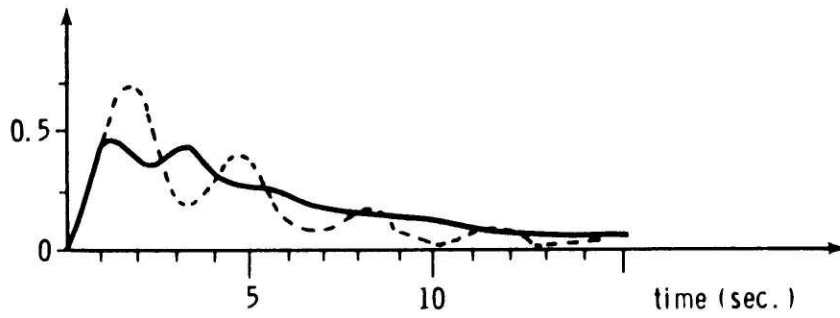

V_x
(fps)

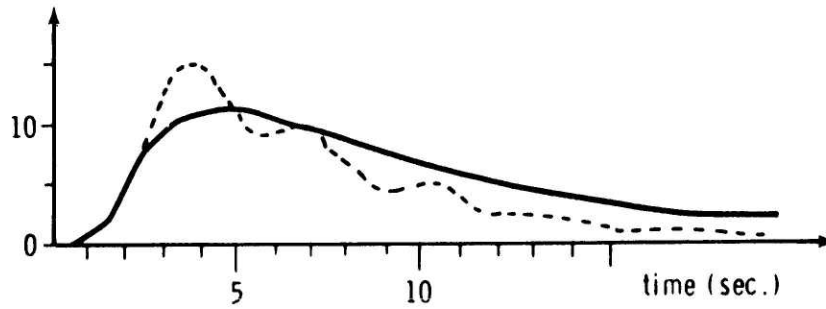

TIME RESPONSE OF THE LINEAR SYSTEM

FIGURE 3.7

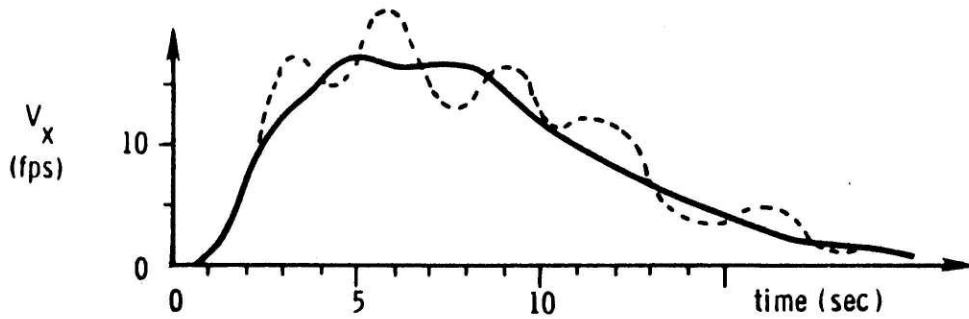
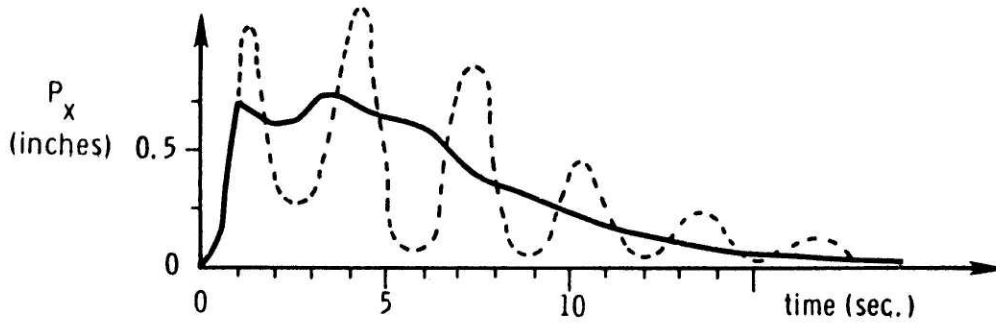
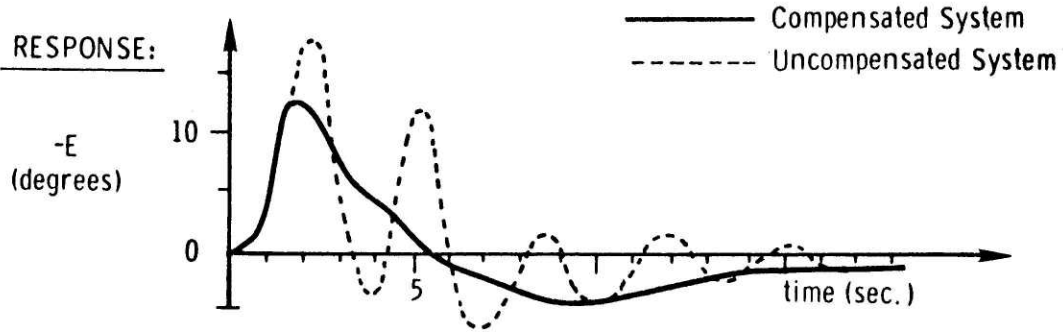
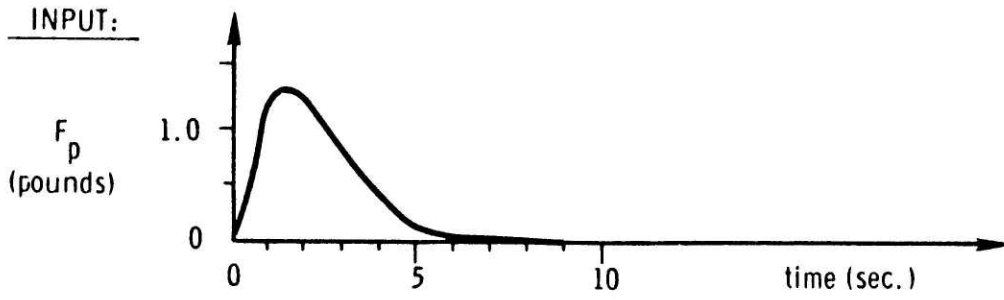

TIME RESPONSE OF THE NON-LINEAR SYSTEM

FIGURE 3.8

CHAPTER IV

EXPERIMENTAL APPARATUS FOR THE FIXED-BASE TEST INSTALLATION

4.1 Introduction

Encouraged by the modest successes of the simulation described in the previous chapters, it was evident that the time had arrived to move to a more sophisticated test installation. The analog simulation provided a launching point for analytic study and design, as well as limited real-time testing of the results of such theoretical work, but two major shortcomings of that simulation could not be denied. The first of these was the absence of the pilot in the loop. The primary purpose of this work is to improve vehicle handling qualities by providing attitude cues to the pilot through the control stick. Without the pilot to interpret these force-feedback cues, they are of little help.

Secondly, no method of updating the vehicle equations of motion was available. Variations in airspeed often result in significant changes in the coefficients of these equations. But in the simulation, these coefficients are translated into gain and potentiometer requirements which remain fixed during a test run. All velocity-dependent parameters and transfer functions in Chapters II and III represented the hover flight condition. It was for this flight condition that analysis and

testing were primarily conducted, but occasional stability and performance checks were undertaken at 40 knots and 90 knots, using root locus and analog techniques.

To overcome these two major deficiencies, a hybrid (digital/analog) simulation of a tandem-rotor helicopter in conjunction with a fixed-base cockpit was employed. Although both longitudinal and lateral dynamics were available, only the former were controlled and displayed. Implicit in such an arrangement is the conventional assumption that there is no cross-coupling between these two modes. To insure completeness and accuracy of the longitudinal response, the effects of vertical motion, as influenced through an Altitude Control System, were included. The overall system, however, remained essentially as shown earlier in Figure 3.2. Typical longitudinal responses in the hybrid system to step control-stick displacements at various airspeeds are shown in Figure 4.1.

4.2 Major Components

The test installation consisted of three major subsystems: a PACE 231-R analog computer, a Honeywell DDP-124 digital computer, and a fixed-base cockpit arrangement. There were no direct ties between the DDP-124 and the cockpit controllers and displays. All such input/output signals were linked through the PACE. The PACE also handled the high frequency transfer functions representing the servo and rotor dynamics and performed

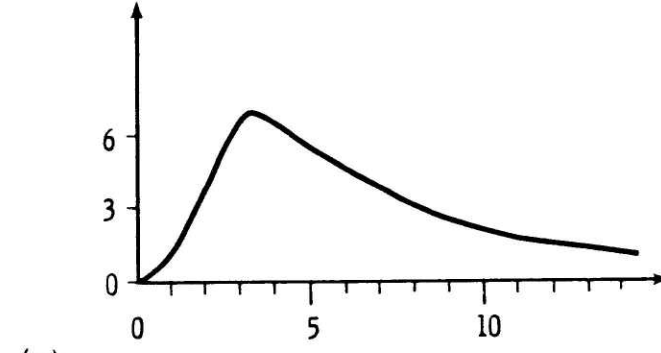
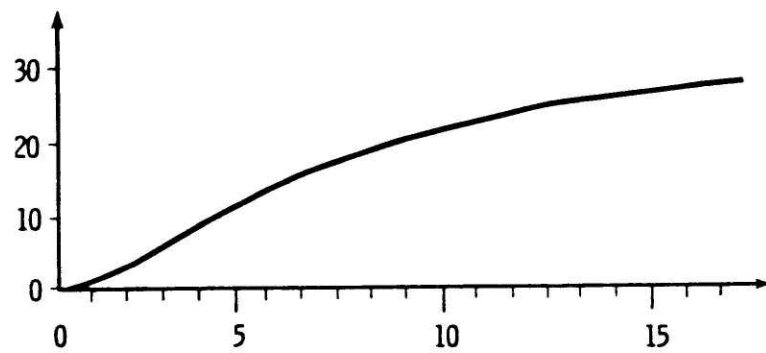
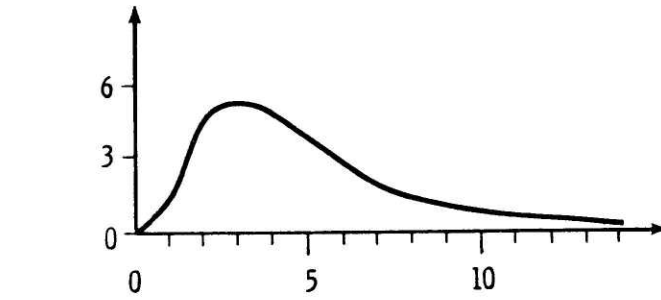
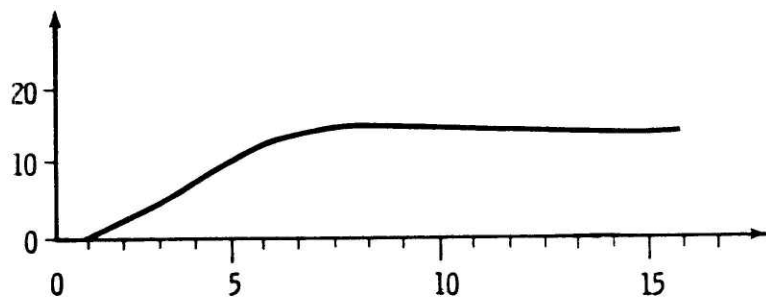
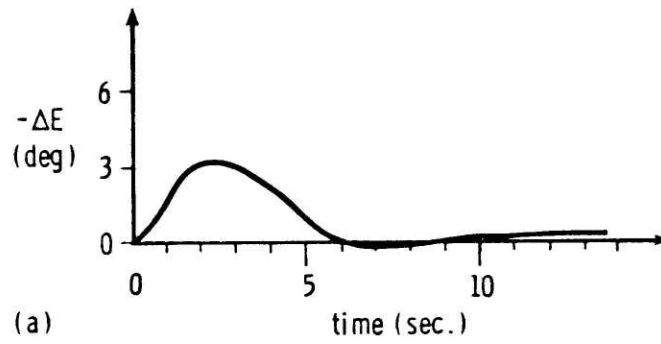
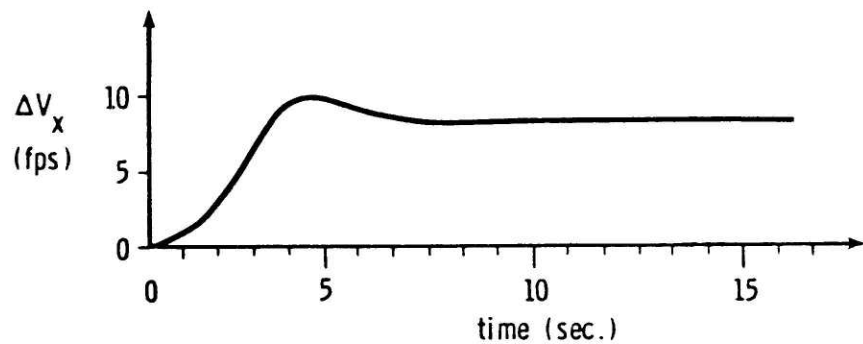

43

LONGITUDINAL STEP RESPONSES AT (a) HOVER, (b) 40 KNOTS, (c) 90 KNOTS

FIGURE 4.1

the Euler angle computations.

All other computations were performed digitally at a sampling interval of 50 milliseconds. Thus, the DDP-124 contained all necessary programming and logic for the flight control system, aerodynamic forces, stability derivative generation, gravity computations, trim computations, inertial cross-coupling effects, and cockpit display and controller signals. A schematic representation of the system and its interfaces is depicted in Figure 4.2. In total, there are 51 digital-to-analog (D/A) and 32 analog-to-digital (A/D) channels available. Virtually all D/A and approximately half of the A/D channels are employed in the simulation, the exact number depending on the particular testing requirements.

The fixed-base cockpit simulator was a mock helicopter cockpit, containing all essential instruments and controls for effective "flight". A conventional flight deck seat provides the pilot with a 29 inch eye-to-display separation. The instrument panel contained nine indicators and an oscilloscope display of north-south and east-west grid lines. These grid lines moved as a function of ground speed, and provided the pilot with a conceptual "picture" of the ground passing under the vehicle.

In addition to the scope, the only instruments used in the tests described in the following chapters were a Sperry Horizon Flight Direction Indicator (attitude gyro), a two-pointer

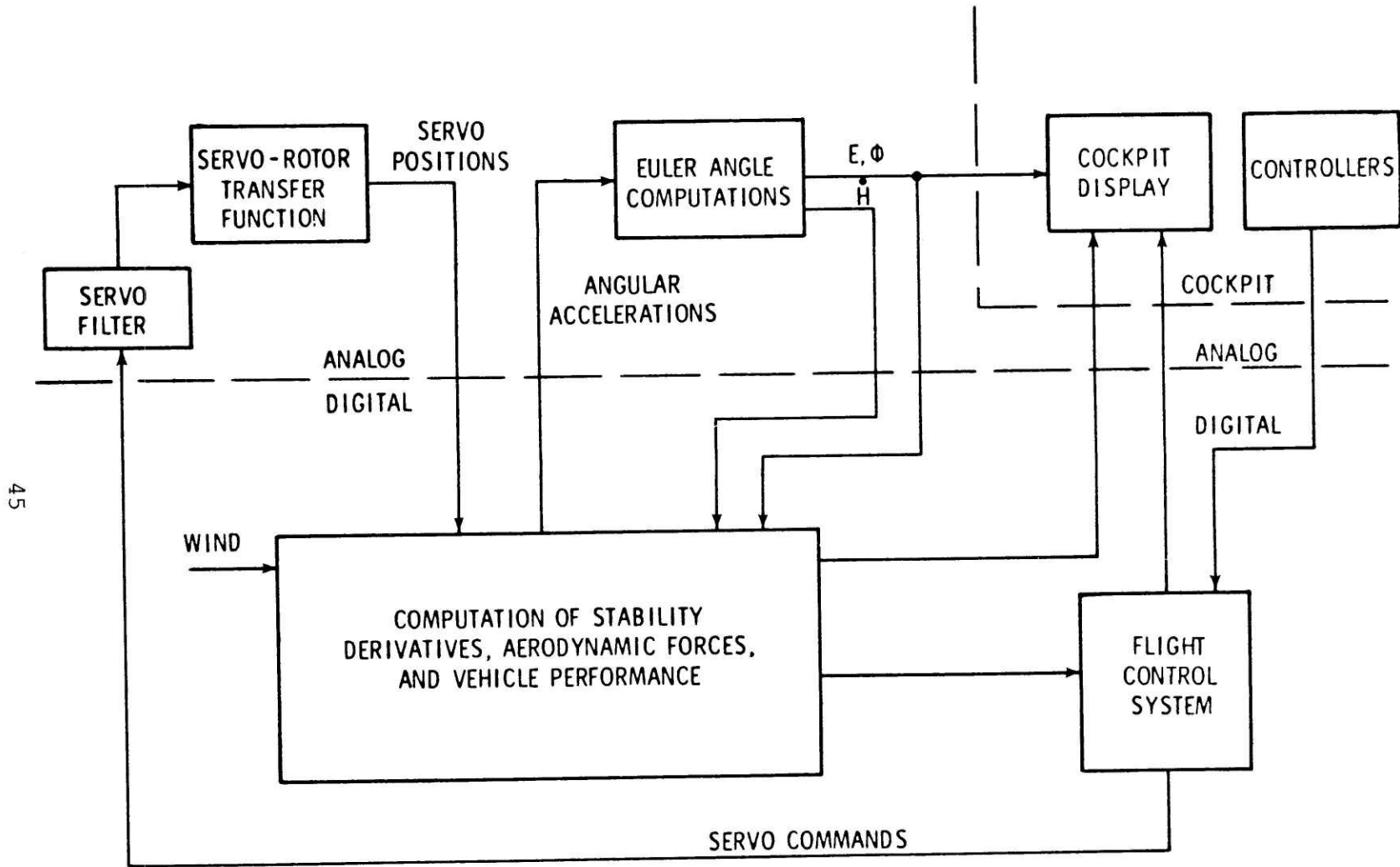

SCHEMATIC REPRESENTATION OF THE TEST INSTALLATION

FIGURE 4.2

velocity indicator, a vertical speed indicator, and an altimeter. The non-standard velocity indicator was designed specifically for this test installation. It consists of a #1 needle which shows commanded velocity (a function of control stick displacement) and a #2 needle which indicates actual velocity. The programmable control stick was mounted at the forward end of the pilot's armrest. Rudder pedals and a collective pitch control (or a direct vertical speed control) were also available, but were not used.

4.3 The Experimental Two-Axis Controller

The pilot's experimental two-axis controller was mounted at the forward end of the right armrest, and it could be deflected to its extreme limits in all directions without excessive effort or unnatural motion of the arm, wrist or hand. The control stick provided the inputs to both the longitudinal and lateral velocity control systems, but only the longitudinal system (XVCS) was employed in the present work. This axis of the controller is designed to provide the following features:

1. Variable centering force gradient (spring stiffness)
2. Variable viscous damping
3. Variable pre-load (dead-band)
4. Force trim by relocation of the zero-force position
5. Automatic realignment of the zero-force position to the zero command signal position.

The variable quantities are also programmable, and it was

the programming of the spring stiffness that was undertaken in this work. A summary of the somewhat reduced limits (due to current safety practices) on the controller is presented in Table I.

TABLE I

Longitudinal Characteristics Experimental Two-Axis Controller	
Maximum Force (pounds)	13.33
Total Travel (arc-inches, measured at middle finger detent on handgrip)	+4.0, -2.0
Spring Stiffness (pounds/inch)	0.572 to 3.333
Damping ($\frac{\text{pounds}}{\text{inch/second}}$)	0.172 to 10.0
Pre-load (pounds)	0.05 to 3.0

The handgrip of the controller is conventional and similar to that found on most stick-controlled aircraft, except that it was mounted on the output member of a position servo. As the pilot applied a force, a strain gauge force transducer in the handgrip produced an electrical signal proportional to the applied force. This signal then commanded the position servo to displace the base of the handgrip in proportion to the force exerted by the pilot (See Figure 4.3). This resulted in a reaction similar to that which would be provided by a conventional spring-centered stick. Note that K_1 of Figure 4.3 is inversely proportional to the spring stiffness. The viscous damping is

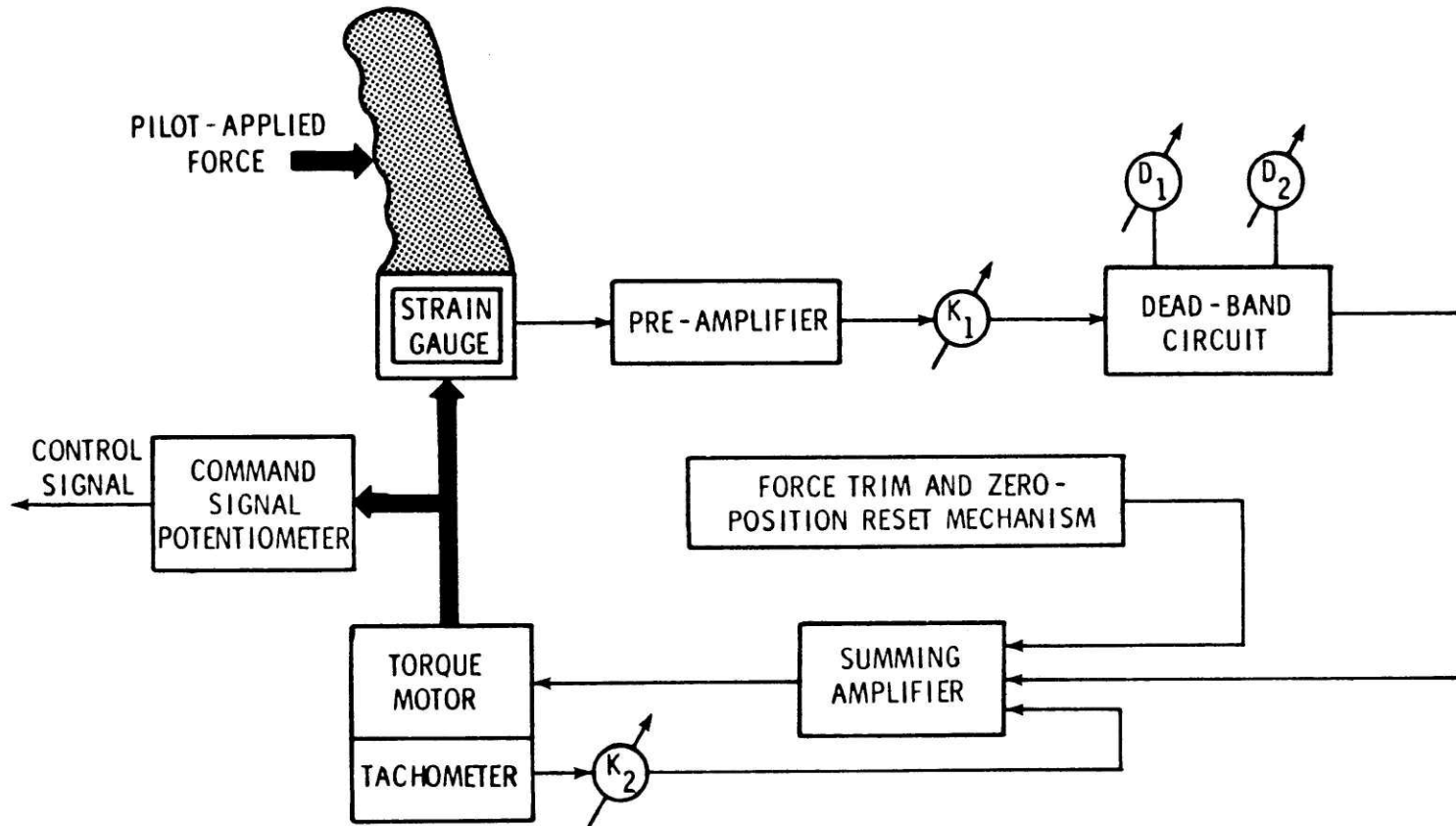

ELECTRICAL SIGNAL \longrightarrow
 PHYSICAL SIGNAL \longrightarrow

SCHMATIC OF THE LONGITUDINAL AXIS OF THE TWO-AXIS CONTROLLER
 FIGURE 4.3

controlled by K_2 , and the dead-band by D_1 and D_2 . The dead-band limits were set at a low value and not varied during the test. K_1 was under program control to provide spring stiffness proportional to pitch attitude and pitch rate, as specified in Section 3.3. K_2 had to be varied with K_1 in order to maintain a constant value of viscous damping. Greater detail on the programming of these parameters appears in Chapter V.

CHAPTER V

SYSTEM PERFORMANCE ON THE FIXED-BASE TEST INSTALLATION

5.1 Introduction

To evaluate the performance of the modified flight control system with the pilot in the loop, two general test categories were proposed. The first of these was a series of attitude control tasks. This sequence of tests was designed to determine whether the attitude-related feedback cues enhanced vehicle handling qualities for attitude-oriented maneuvers. The second set of tests involved velocity-tracking tasks. These tests were conducted to assess whether any degradation of the primary purpose of the overall system -- velocity control -- had occurred. All such tests were run using fixed as well as programmable control stick feel characteristics to provide a basis for comparison. After completing lengthy preparations, a considerable quantity of data was collected from these tests and reduced to evaluate the merits of the proposed control stick characteristics.

5.2 Engineering Preparations for the Simulator Tests

To modify the existing simulation of the CH-46C helicopter and to make provisions for all data recording and monitoring requirements, numerous changes and additions had to be made to the digital and analog systems and to the cockpit mock-up

hardware. The most extensive modifications involved the writing, inputting and testing of digital programs to generate the appropriate control stick characteristics, to furnish a random tracking signal, to insure compatibility of the recording equipment with the signals to be recorded, and to compute the statistics of selected quantities.

As determined in Chapters II and III, the program governing the control stick dynamics had to generate a spring stiffness given by:

$$\begin{aligned}
 k &= k_o + S_k (E + \tau_c \dot{E}) [\text{sign}(P_x)] \frac{\text{pound}}{\text{inch}} \\
 &= 0.25 - 0.0664 (E + 1.41\dot{E}) [\text{sign}(P_x)] \quad (5.2.1)
 \end{aligned}$$

where E and \dot{E} are in degrees and degrees/second, respectively. This value of k was computed digitally, but was limited due to control stick restrictions, with a lower bound of 0.572 and an upper bound of 3.333 pounds/inch (See Table I). To maintain the specified constant stick damping also required a variable input to one of the control stick servomechanism devices, because K_2 of Figure 4.3 governs the time constant of the control stick (τ_{cs}). This parameter is defined as:

$$\tau_{cs} \equiv \frac{c}{k} = \frac{0.778}{k} \text{ seconds} \quad (5.2.2)$$

To successfully negotiate the interface from the digital computer through the analog system to the controller required the generation of voltages for k and τ_{cs} in compliance with

calibration curves for the hardware. This presented no problems in that both curves were linear in $\frac{1}{k}$. The variable control stick mechanisms, however, would not accept non-negative voltages and were limited in their maximum input voltages. These constraints established the limits on certain control stick characteristics shown earlier in Table I. The problems imposed by these limits are discussed later in this chapter.

To provide a record of each test run and a basis for statistical study of the results of these runs, numerous quantities were recorded on two 8-track Brush recorders operating together synchronously. The statistical content (mean, mean-square and variance) of selected signals was also computed concurrently with each run and stored in computer memory for retrieval at the completion of each task. A third source of data was generated from controlled counters which would increment whenever a particular signal was within a specified tolerance band. These counters were normalized with respect to real test time, to provide the fraction of time that the signals were within the specified limits.

Among the 16 signals recorded graphically were the control stick displacement, spring stiffness, pilot-applied force, pitch angle, pitch error (for attitude control tasks only), velocity, commanded velocity and velocity error (for velocity tracking tasks only), pitch rate, certain statistical properties, and signals indicating the modes of operation and testing employed.

Statistics were generated on the pitch angle error or velocity error (as appropriate to the nature of the task) and pitch rate. The controlled counters generally operated on the same quantities.

Prior to each test run, extensive cockpit checkouts and system static tests were undertaken. These procedures were employed to insure that all components were properly functioning and that all instruments were accurately calibrated. Intermediate calibration checks were also performed during the testing periods to suppress any possible drift of the instruments.

The sequence and duration of the test runs were also carefully controlled and monitored to insure that the results were unbiased by the experimental procedure. These considerations involved the providing of adequate practice time for the pilot to reach a plateau on his learning curve before the tests were begun, and to terminate testing if fatigue effects were encountered. Additionally, the tests were given in random order to prevent a memorized response to a frequently-repeated task.

5.3 Attitude Control Tests

As was shown in earlier chapters, the velocity control system under study contains a Pitch Attitude Control System (PACS) as an inner loop. The PACS was designed to provide

optimum velocity (outer loop) performance, but when the pilot is confronted with an attitude control task, difficulties may be encountered. To assess the value of spring stiffness proportional to pitch and pitch rate in circumventing these problems and enhancing vehicle handling qualities, a series of attitude control tests was conducted. These tests consisted of five distinct tasks, wherein the vehicle was to be accelerated or decelerated while attempting to maintain a constant specified pitch attitude. All phases of these tasks were well within the flight envelope of the vehicle. Noting that for hover the trimmed flight pitch angle is approximately $+10^\circ$, these tasks were:

- Task 1: Accelerate, hover to 40 knots, at $+5^\circ$ pitch.
- Task 2: Accelerate, hover to 60 knots, at 0° pitch.
- Task 3: Accelerate, hover to 85 knots, at -5° pitch.
- Task 4: Decelerate, 90 knots to 10 knots, at $+20^\circ$ pitch.
- Task 5: Decelerate, 60 knots to hover, at $+15^\circ$ pitch.

Statistics were computed on the pitch angle error (E_c) and the pitch rate (\dot{E}). These statistics included the mean, mean-square and variance of each quantity, with data updated at a sampling interval of 50 milliseconds. The primary performance criteria for these tasks was the mean-square pitching error ($\overline{E_c^2}$). The use of such a quantitative performance measure is justified by Obermayer¹⁰, who concluded that an experienced pilot's action, when attempting to minimize tracking

errors, "is tantamount to minimizing mean-square error". The mean-square pitch rate ($\overline{E^2}$) provides a measure of the inner loop response and the smoothness with which the vehicle was flown during the test. As an additional performance indicator, the controlled counters were programmed to record the fraction of test time that the magnitude of the pitch error was less than one degree.

To combat the potentially misleading effects of the large initial pitch errors at the beginning of each run (e.g., 15° for Task 3), statistical data collection was not commenced until the vehicle velocity had become, for Tasks 1 through 5: 5, 5, 10, 80, and 50 knots, respectively. This was accomplished with the aid of a recording assistant, who observed vehicle velocity on a digital voltmeter and engaged the statistical program and controlled counters when the specified velocity was reached. He likewise terminated the data collection when the final velocity for the task was achieved. Briefly delaying the initiation of the statistics program allowed sufficient time for the vehicle to approach the desired attitude, but did not eliminate the transient overshoots or undershoots, which could be significant in the evaluation of the effectiveness of the force feedback cues.

After sufficient pilot practice, the tasks were flown in random order, using both the "nominal stick" ($k=0.973 \frac{\text{pound}}{\text{inch}}$) and the "programmed stick" (k given by Equation 5.2.1). The

tasks were conducted over several testing periods, and included a minimum of five and a maximum of twelve data runs for each task with each stick. A total of 72 data runs were made for this sequence of attitude control tests.

The pitch angle errors for a typical run is shown in Figure 5.1. A qualitative improvement using the programmable

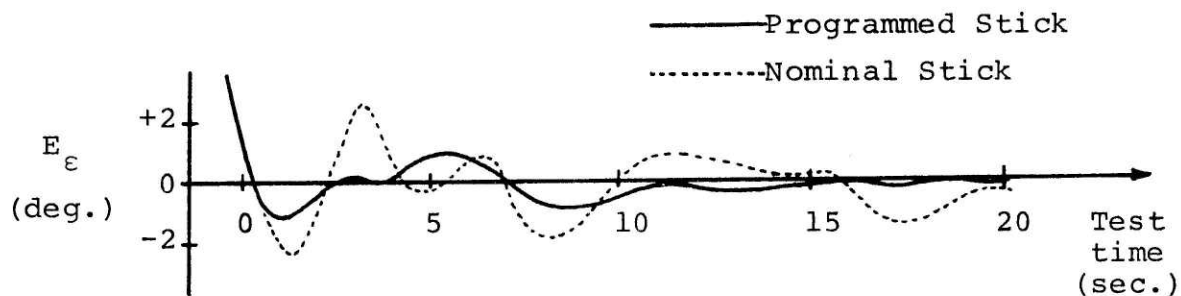

Figure 5.1 Typical Pitch Errors for an Attitude Control Task

stick is quite evident from these error traces, and pilot opinion substantiated this qualitative impression. The quantitative results are compiled in Table II. The percent improvement is defined as the difference in the means divided by the mean for the nominal stick. The statistical significance in the last column of this Table may be interpreted as the probability that a decrease (or increase) in the means is actually due to improved system performance, as opposed to chance sampling. A more detailed explanation of the statistical analysis, as well as sample calculations, can be found in

TABLE II

RESULTS OF ATTITUDE CONTROL TASKS					
Task	Quantity	Mean of Quantity		Percent Improvement	Statistical Significance
		Nominal Stick	Programmed Stick		
1	$\overline{E_\epsilon^2}$ Mean-Square Pitch Error (degrees) ²	1.40	0.75	46.3	0.95
2		1.72	0.70	59.4	0.99+
3		2.50	0.74	70.5	0.99+
4		5.94	1.49	75.0	0.99+
5		4.63	1.21	73.8	0.99+
1	$\overline{\dot{E}^2}$ Mean-Square Pitch Rate ($\frac{\text{degrees}}{\text{second}}$) ²	1.81	0.86	52.6	0.95
2		2.79	1.26	55.0	0.99+
3		2.74	1.57	42.6	0.99+
4		7.26	3.36	53.8	0.98
5		5.66	1.34	76.4	0.99+
1	Fraction of Time $ E_\epsilon < 1^\circ$	0.604	0.728	20.5	0.97
2		0.615	0.794	29.0	0.99+
3		0.537	0.786	46.2	0.99+
4		0.241	0.534	121.7	0.99+
5		0.381	0.631	65.7	0.99+

Appendix B. These quantitative results indicate a substantial and meaningful improvement in attitude control performance when using programmable control stick dynamics. A complete discussion of these and other results is given in Section 5.6.

5.4 Velocity Tracking Tests

The use of force feedback cues to the pilot proportional to pitch and pitch rate had shown a successful enhancement of vehicle handling qualities for attitude maneuvers. To be of value in the overall system, however, these variable control stick dynamics must not affect velocity control adversely. Any such degradation in the primary function of the control system would detract from, if not completely negate, the useful qualities of the programmed stick.

To evaluate the effect of attitude-dependent control stick dynamics on a velocity-oriented task, a velocity command signal was generated for the pilot to track. This random signal was synthesized from filtered white noise, and a 2.25 minute record of this signal was stored in the digital computer. A program would then retrieve this signal, reading it forward and then backward cyclically. This resulted in a continuous tracking signal with a period of 4.5 minutes. This signal was scaled to cover a velocity range of -8 to +75 knots, and was furnished as an input to the #1 needle of the non-standard airspeed indicator (discussed in Chapter IV).

The pilot's task was to minimize the tracking error. This error was displayed to the pilot as the difference between the #1 and #2 needles, where the latter indicated the actual velocity of the vehicle. Statistics were computed on the velocity error signal (V_{ϵ}) and the pitch rate, with the mean-square velocity error ($\overline{V_{\epsilon}^2}$) being the primary performance indicator. The controlled counters were incremented whenever the magnitude of the velocity error was less than five feet/second (2.96 knots).

The rather surprising results for twelve data runs of this difficult tracking task are shown in Table III. Not only was there no degradation of velocity control performance, but mean-square error criteria indicated a slight, yet statistically significant, improvement when using the programmable controller.

This task was found to be difficult and taxing on the pilot in that the problem was basically one of chasing a randomly moving needle. The struggle to keep up with and prevent overshooting this needle was further compounded by the considerable lag in the velocity response of the helicopter.

TABLE III

RESULTS OF VELOCITY TRACKING TESTS				
Test Quantity	Mean of Quantity		Percent Improvement	Statistical Significance
	Nominal Stick	Programmed Stick		
$\overline{V_{\epsilon}^2}$ Mean Square Vel. Error $\left(\frac{\text{Feet}}{\text{second}}\right)^2$	86.8	77.0	11.3	0.98
$\overline{\dot{E}^2}$ Mean-Square Pitch Rate $\left(\frac{\text{degrees}}{\text{second}}\right)^2$	24.84	23.18	6.7	0.62
Fraction of Time $ V_{\epsilon} < 5 \text{ fps}$	0.385	0.412	7.0	0.90

5.5 Related Tests

To determine the relative influence of pitch and pitch rate feedback cues to the pilot in an attitude control task, several other formulations for the spring stiffness were investigated. In each case, k was a function of either pitch

or pitch rate, but not both. The expressions for spring stiffness implemented in the computer for testing were:

$$k_1 = 0.572 - 0.125 (E) [\text{sign}(P_x)] \quad (5.5.1)$$

$$k_2 = 0.572 - 0.125 (1.41 \dot{E}) [\text{sign}(P_x)] \quad (5.5.2)$$

$$k_3 = 0.973 - 0.0664 (1.41 \dot{E}) [\text{sign}(P_x)] \quad (5.5.3)$$

In the first two equations, the constant value (0.572) was selected because it was the hardware limitation on the minimum value of spring stiffness (See Table I). This value, which was larger than that programmed in the computer for the previous tests (See Equation 5.2.1) was used to prevent the "masking" of k variations when E or \dot{E} was small. S_k was also increased in magnitude to -0.125 to account for the elimination of the influence of E or \dot{E} on k . In Equation (5.5.3), the constant value (0.973) chosen was the nominal value of spring stiffness used in earlier tests. Variations about this nominal value were a function of the vehicle pitch rate, using the optimal coefficients found in Chapter III.

Five runs of Task 5, as defined in Section 5.3, were conducted with each of these new control stick stiffness relationships. Using mean-square pitch error as a performance measure, and the nominal stick value for the mean of $\overline{E_c^2}$ (4.63 degrees²) as a reference, the results of these tests are given in Table IV. Even these somewhat subjectively-chosen relations for the spring stiffness showed considerable

and significant improvement. Most encouraging were the

TABLE IV

RESULTS USING SUB-OPTIMAL SPRING STIFFNESS			
Spring Stiffness	Mean of $\overline{E_\epsilon^2}$ (degrees) ²	Percent Improvement	Statistical Significance
k_1	2.84	38.8	0.99+
k_2	2.78	39.9	0.99+
k_3	1.26	72.8	0.99+

results based on the formulation for k_3 . Its performance nearly matched that of the optimally programmed controller for this task. A complete discussion of the results of all tests described in the last three sections is given in the following section.

5.6 Discussion of Results

The qualitative results of the tests described in Sections 5.3 through 5.5, based primarily on pilot opinion of the programmable control stick characteristics and visual observation of the graphical test records, were strongly in favor of the attitude-related feedback cues. Extensive

quantitative results in the form of statistical data verified this substantial improvement in system performance when using a control stick with such force-feel characteristics, both in an attitude-control and a velocity-control environment.

The "feel" of the control stick, in the opinion of the operator, did provide a significant and discernable attitude cue. But the otherwise enthusiastic response of the pilot for the programmed stick was tempered with one reservation, which evolved from a hardware restriction. The lower limit on the available spring stiffness ($0.572 \frac{\text{pound}}{\text{inch}}$) resulted in occasional discontinuities in that parameter. Generally these discontinuities were not perceptible to the operator, but for rapid pitching oscillations around the trimmed attitude, they were disconcerting. The stick would tend to surge under such conditions, but there was no difficulty in overpowering the control stick, if need be, although the best solution was generally found to be easing the force on the stick slightly. This surging condition was not encountered under normal (relatively smooth) pitching motions. It is felt that any such distracting jerkiness in the control stick encountered in an actual airborne vehicle would be inconsequential compared to the total pilot discomfort resulting from the violent motion involved.

Very little acclimation time was needed by the pilot to

garner useful information from the variable control stick dynamics. In the attitude control tasks, these cues were extremely helpful both in setting and maintaining the desired attitude. The pitch rate cue seemed particularly effective in this regard, as any deviation from the desired attitude could immediately be felt in the control stick as an easing or increasing of pressure on the operator's hand. The natural and desired reflex on behalf of the pilot was to position the stick in such a way as to restore the constant force.

This pitch cue from the controller was often detected before the motion was noticed on the gyro horizon, which explains, in part, the improved performance of the programmed stick over the nominal stick. With the nominal stick, the pilot had to depend on the coarsely-graduated gyro horizon for all attitude information. This would tend to indicate the potential for an even more substantial improvement in system performance in an actual helicopter, where pilot attention cannot be focussed on only one instrument. Any additional information, such as an attitude cue from the force-feel characteristics of the control stick, could be of considerable value in the safe and efficient flight of the vehicle.

The sub-optimal formulations of control stick stiffness

given by Equations (5.5.1) through (5.5.3) gave some indication of the relative merits of pitch versus pitch rate feedback. The first formulation, which had no rate feedback, eliminated the surging problem described above, but also diminished the attitude cue to the point that it was not discernable, except possibly subliminally. The second formulation, a function of rate feedback only, provided meaningful attitude cues, but was even more sensitive with regard to surging, due to the larger coefficient of the pitch rate term. The final formulation (5.5.3) provided dynamic characteristics which were, according to pilot opinion, as good as those of the optimally programmed controller. Due to the larger constant value, the lower limit on controller stiffness was infrequently reached, eliminating the tendency to surge. Only with the most rapid stick oscillations was this undesirable discontinuity encountered.

The quantitative results of the tests are shown in Tables II through IV. Using mean-square error criteria, the programmable control stick clearly improved vehicle handling qualities, particularly with regard to attitude control tasks. The most dramatic improvement was observed for the deceleration maneuvers (Attitude Control Tasks 4 and 5). This might indicate that the system could be particularly useful in making landing approaches or slowing to hover. The data from the controlled counters substantiated the mean-square error findings.

An even greater indication of the merits of the attitude dependent control stick characteristics was found through further analysis of the tabulated results. The statistical significance of the improvement, as described earlier, merely gives the probability that some improvement is evident, but it does not indicate how much. For a given confidence level, however, the minimum amount of improvement can be computed. This was done for the mean-square error criteria of Attitude Control Tasks 2 through 5. With a probability of 0.99, the following minimum improvements using the programmed stick could be expected:

Task 2.	Minimum Improvement:	31.7%
Task 3.	Minimum Improvement:	12.5%
Task 4.	Minimum Improvement:	35.4%
Task 5.	Minimum Improvement:	53.1%

This further verified the improved system performance using programmable stick force characteristics, particularly for the deceleration maneuvers. The least significant improvement (Task 1), was also the task with the minimum pitch angle excursion ($\approx 5^\circ$) from initial conditions to the target attitude. In such a task, the potential of the programmable dynamics was not fully exploited.

A final performance measure was the mean-square pitch rate. This indicator of inner loop response provided a clue

to the smoothness with which the test vehicle was flown. The statistics for this criteria followed the same general trend as the error signals and the controlled counters. This is in consonance with the generally-accepted maxim that the smoother a vehicle is flown, the easier it is to control. The programmable controller clearly aids in achieving this goal.

CHAPTER VI

CONCLUSIONS AND RECOMMENDATIONS

6.1 Conclusions

The results of the fixed-base simulator tests of Chapter V clearly indicated a substantial and significant improvement in vehicle handling qualities using the optimal control stick characteristics derived in Chapters II and III. Undesirable pitching motions and mean-square pitching errors for attitude control tasks were reduced by 43 to 76 percent. The most dramatic improvement in performance occurred in deceleration tasks. This indicates that the use of programmable control stick force-feel characteristics may be of particular value to the pilot in making approaches to landings or slowing to hover.

The use of attitude-dependent feedback cues had no adverse effect on the primary purpose of the control system--velocity control. Indeed, performance was also improved in this realm of maneuvering flight. Despite the rather demanding nature of the longitudinal control tasks undertaken, the overall trend was to a much smoother "flight". This leads one to conclude that more precise vehicle control could also be achieved in less difficult tasks. Superficial tests of several sub-optimal formulations for the programmed control stick

stiffness also showed meaningful improvement in system performance. This further attests to the feasibility of using attitude cues to the pilot through programmed control stick characteristics to improve vehicle handling qualities.

The linearization method used in the analysis of the system has been validated by simulation tests of the complete system.

6.2 Recommendations

Despite the promising potential of the programmable controller, it should not yet be heralded as the panacea for VTOL handling problems. The results obtained in this work were achieved under carefully controlled experimental conditions. The inherent vibrational environment in a helicopter may require adjustments in the magnitude, or partially negate the effectiveness, of the attitude feedback cues. On the other hand, the heavier control burden on the pilot in an airborne vehicle, due to numerous side tasks and other in-flight considerations, makes him generally receptive to any source of additional control assistance. Consequently, the programmable control stick may prove to be even more beneficial under such conditions than it has been in the relatively ideal laboratory surroundings.

To properly evaluate the effectiveness of attitude-dependent controller characteristics, it is therefore

recommended that a test flight program in the actual vehicle be implemented and conducted. Should such a flight test support the value of the controller, an investigation of the lateral degrees of freedom is proposed. The more complicated dynamics of this mode and the coupling effects between the longitudinal and lateral modes suggest a potential for considerable handling quality improvement by programming the lateral stick stiffness as a function of roll and roll rate. This system should likewise be evaluated through flight testing in the actual vehicle.

Further simulator tests would also appear fruitful. The effects of random disturbances--wind gusts, for instance--would be a valuable contribution. More sophisticated and realistic flight conditions could also be probed, such as ILS approaches or tactical maneuvers.

Other formulations for the spring stiffness might also be investigated. The expression given by Equation (5.5.3) showed great promise despite its limited testing. Another alternative would consider the programming of control stick force as a function of attitude quantities. This would eliminate some of the non-linearity problems encountered by programming control stick stiffness.

APPENDIX A

THE INTERFACE WITH AN ACTIVE ENGINEERING GROUP

The preliminary work on this thesis involved literature searches and theoretical analysis of the embryonic system, including compensation design and parameter optimization. Analog simulation was used to verify the findings of this analytic work, but the system soon grew beyond the capabilities of the analog computer.

At the onset of this work, however, the possibility, but not the assurance, of using a sophisticated fixed-base test installation to complete the critical pilot/vehicle interface was recognized. This test installation was under the project control and heavy use of an active engineering group conducting research in fields from which this thesis evolved. To secure the use of this test facility, the first step was an oral presentation, to the group, of the rather promising results from the analog simulation and the proposed use of their equipment for further testing.

Having successfully passed this first hurdle, the next pursuit was to develop a detailed test plan listing all hardware, software and manpower requirements, including the assignment of priorities for individual tasks. Several conferences with group and section leaders led to the ultimate

acceptance of this test plan after a few minor revisions.

The scheduling of this testing proved to be one of the more difficult phases of this operation. Not only did the time for this research have to be integrated into the schedule of group work, both manpower- and equipment-wise, but it had to take into account the academic program of the author. A further constraint was the required presence of a group engineer for technical assistance and as a safety monitor during use of the test installation. These considerations, as well as hardware difficulties and several pre-emptive needs of the group, resulted in substantial delays before preparations for the test program could get underway.

The pre-testing preparations were most educational and enlightening. Not only was considerable experience logged in machine-language computer programming and debugging, but an insight into the meticulous documentation and check-out procedures involved in engineering work was gained. The inexplicably fickle nature of "on-again, off-again" hardware items was also observed. The actual test sessions, however, generally ran smoothly and efficiently.

By strict adherence to the test plan, all necessary system testing and evaluation was completed in the allotted time. Some additional time was made available, and preliminary investigations on several lower-priority tasks were

undertaken. The approaching thesis deadline date and a high-priority group assignment, however, resulted in the ultimate termination of experimental work.

APPENDIX B

STATISTICAL ANALYSIS OF THE TEST RESULTS

The quantitative test results of Chapter V were based on the statistical analysis of various test quantities. This analysis was conducted by using established procedures which may be found in any standard textbook treating the engineering applications of statistical methods¹¹.

The mean, or average, of a set of measurements, X_i , is computed by

$$\bar{X} = \frac{1}{N} \sum_{i=1}^N X_i \quad (\text{B.1})$$

where N is the number of measurements taken. For two sets of measurements, some comparison of the means is often considered, such as the columns labelled "Percent Improvement" in Tables II, III and IV of the text.

The question in point is how much significance, if any, can be attached to the difference between the two means. This difference is a random variable with standard statistical properties, and by assuming normal probability distributions, a "t" value may be computed. A standard t-table can then be entered to determine the significance of this difference in the means. This significance is a function not only of the

difference in the means, but also of the respective number of data points from each sample set and the dispersion of these data points. The expression for this t value is:

$$t = \frac{\bar{X}_1 - \bar{X}_2}{s_p \left[\frac{N_1 + N_2}{N_1 N_2} \right]^{0.5}} \quad (\text{B.2})$$

where s_p^2 is the "pooled" estimate of the population variance, given by

$$s_p^2 = \frac{\sum_{i=1}^{N_1} (X_{1i} - \bar{X}_1)^2 + \sum_{j=1}^{N_2} (X_{2j} - \bar{X}_2)^2}{N_1 + N_2 - 2} \quad (\text{B.3})$$

The remaining argument needed to enter the t-table is the degree of freedom of the data:

$$\text{d.f.} = N_1 + N_2 - 2 \quad (\text{B.4})$$

For example, consider the following test samples:

Sample 1 ($N_1=7$)		Sample 2 ($N_2=8$)	
7.99	6.63	1.94	0.73
3.14	9.46	1.12	1.20
3.42	4.32	1.24	1.46
6.65		3.13	1.12

By applying Equation (B.1), the means are

$$\bar{X}_1 = \frac{41.61}{7} = 5.94 \quad ; \quad \bar{X}_2 = \frac{11.94}{8} = 1.49$$

From (B.3), (B.2) and (B.4):

$$s_p^2 = \frac{(34.25) + (3.89)}{13} = 2.934$$

$$s_p = 1.713$$

$$t = \frac{(5.94) - (1.49)}{(1.713)(0.517)} = 5.025$$

$$\text{d.f.} = 13$$

The t-table is then entered:

d.f.	Statistical Significance		
	0.90	0.95	0.99
.	.	.	.
.	.	.	.
.	.	.	.
12	1.356	1.782	2.681
13	1.350	1.771	2.650
14	1.345	1.761	2.624
.	.	.	.
.	.	.	.
.	.	.	.

A value of t greater than 2.650 indicates a statistical significance of greater than 0.99. In fact, the value of 5.025 corresponds to a significance on the order of 0.9999.

To carry the analysis a step further, a minimum decrease (or increase) in the mean (Δ) can be computed for a specified statistical significance (e.g., 0.99). Using

$$t_{(0.99;13)} = 2.650 = \frac{(\bar{X}_1 - \bar{X}_2) - \Delta}{s_p \left[\frac{N_1 + N_2}{N_1 N_2} \right]^{0.5}} \quad (\text{B.5})$$

and solving for Δ yields a value of 2.103 as the minimum decrease in the means. This can then be translated into a minimum improvement of $\frac{\Delta}{\bar{X}_1} (100) = 35.4\%$.

The above calculations were based on the actual mean-square pitch error data in Attitude Control Task #4 (See Section 5.3). Sample 1 was from the nominal stick and Sample 2 was from the programmed stick. The difference in the means, and the corresponding improvement in performance, was clearly not due to random sampling. Since the only experimental variable between the sets of data was the different controller characteristics, the conclusion is drawn that the improved system performance was a result of the programmed force-feel characteristics in the control stick.

REFERENCES

1. Kaufman, L.A., "A Concept for the Development of a Universal Automatic Flight Control System for VTOL Aircraft", Journal of the American Helicopter Society, Vol. X, No. 1, January 1965.
2. Miller, R.H., R.W. Simpson, et al, A Systems Analysis of Short Haul Air Transportation, MIT Flight Transportation Laboratory, Technical Report 65-1, August 1965.
3. Jamieson, J.G., "Use of Programmable Stick-Force Characteristics to Improve Aircraft Handling Qualities", SM Thesis, Department of Aeronautics and Astronautics, MIT, March 1971.
4. Cooper, G.E., "Understanding and Interpreting Pilot Opinion", Aeronautical Engineering Review, Vol. XVI, No. 3, March 1957.
5. MIL-F-8785B(ASG), "Military Specification - Flying Qualities of Piloted Airplanes", U.S. Government Printing Office, 1969.
6. Todd, M.L., "Design of a System for Longitudinal Control of VTOL Aircraft", SM Thesis, Department of Aeronautics and Astronautics, MIT, June 1966.
7. Oakes, H.S., "A Feasible Feel Augmentation System for Helicopters", AGARD Conference Pre-Print No. 86 on Helicopter Guidance and Control Systems, June 1971.
8. Rediess, H.A., "A New Model Performance Index for the Engineering Design of Control Systems", Doctoral Thesis, Department of Aeronautics and Astronautics, MIT, December 1968.
9. Palsson, T., "Parameter Uncertainties in Control System Design", Doctoral Thesis, Department of Aeronautics and Astronautics, MIT, May 1971.
10. Obermayer, R.W., R.B. Webster and F.A. Muckler, "Research Study on Optimal Manual Control Systems", Bunker-Ramo Corporation, Final Report, June 1966.
11. Dixon, W.J. and F.J. Massey, Jr., Introduction to Statistical Analysis, McGraw-Hill Book Co., Inc., New York, 1951.