

100% Petroleum House

by
David Costanza

BSArch Bachelor of Architecture
University of Utah (2009)

Submitted to the Department of Architecture
in Partial Fulfillment of the Requirements for the Degree of

Master of Architecture

at the
Massachusetts Institute of Technology
February 2013

© 2013 David Costanza
All Rights Reserved

The author hereby grants to MIT permission to reproduce and to
distribute publicly paper and electronic copies of this thesis document in whole or in part
in any medium now known or hereafter created.

Signature of Author

Department of Architecture
January 17, 2013

Certified by:

J Meejin Yoon
Associate Professor of Architecture
Thesis Supervisor

Accepted by:

Takehiko Nagakura
Associate Professor of Design and Computation
Chair of the Dept. Committee on Graduate Students

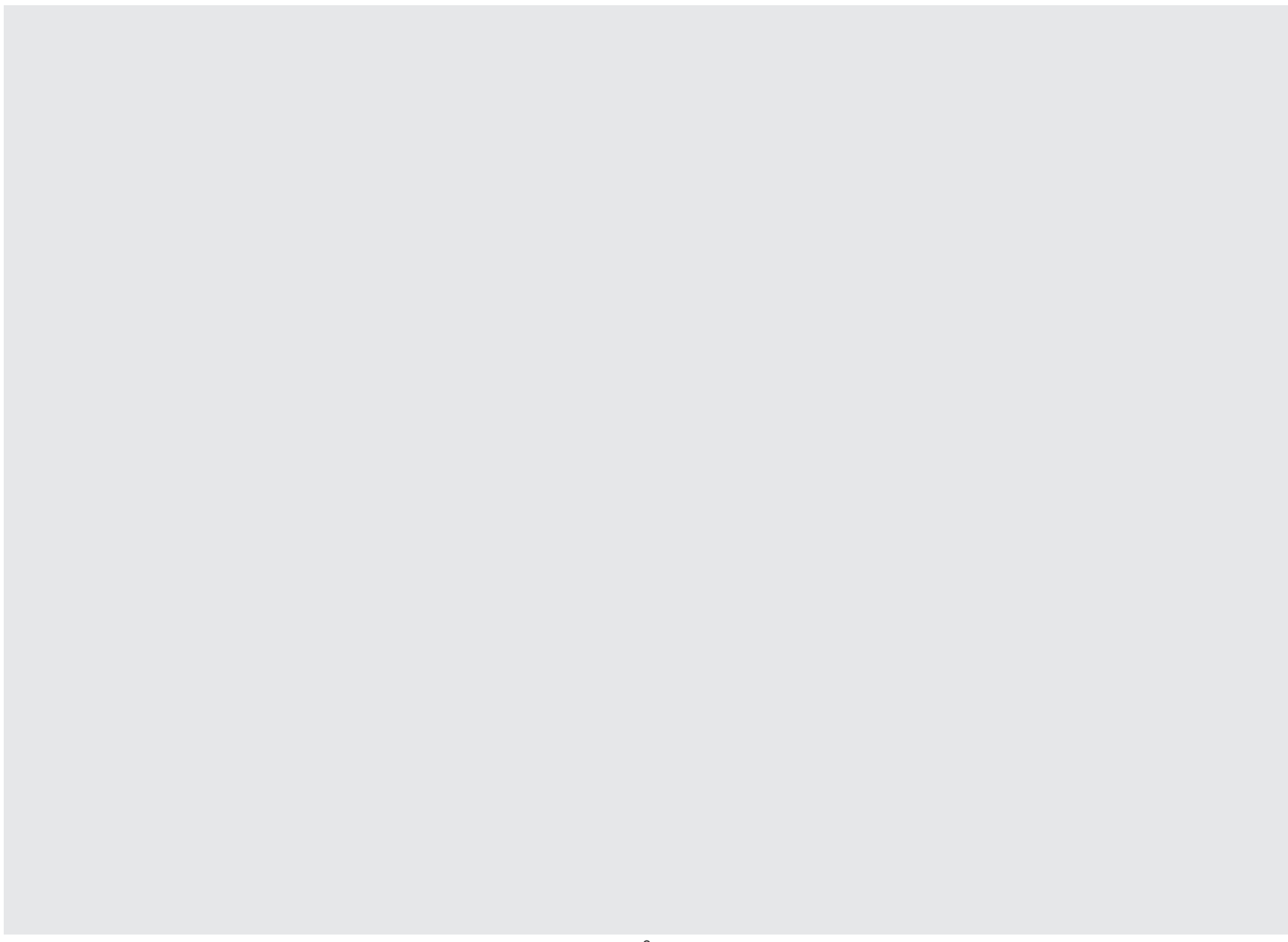

THESIS COMMITTEE

Advisor

Meejin Yoon
Associate Professor

Readers

Brandon Clifford
Lecturer

Dennis Shelden
Associate Professor of Practice

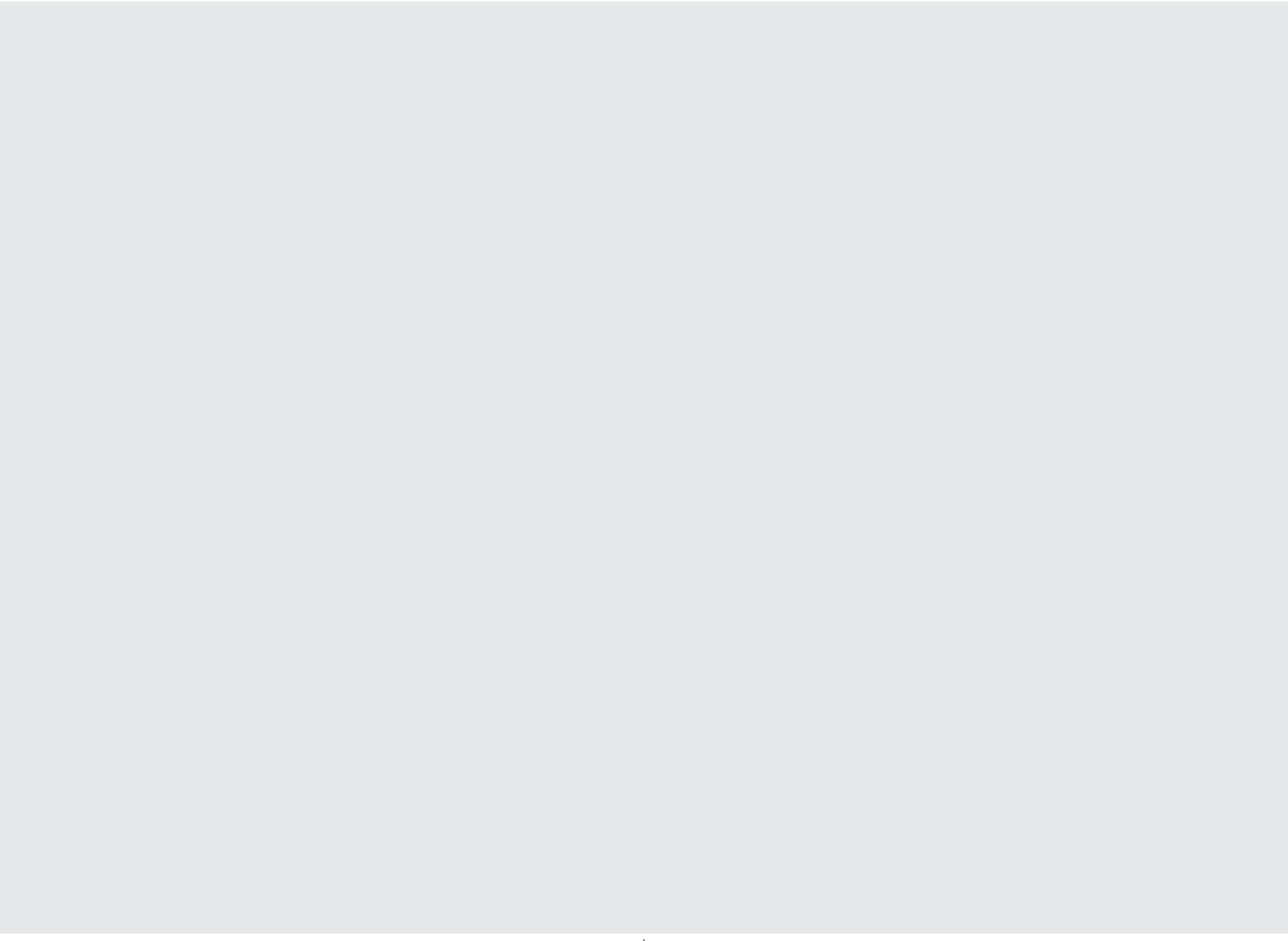

100% Petroleum House

by

David Costanza

Submitted to the Department of Architecture on
January 17, 2013 in Partial Fulfillment of the Requirements
for the Degree of
MASTER OF ARCHITECTURE

Thesis Supervisor: J. Meejin Yoon
Associate Professor of Architecture

ABSTRACT

I am designing a Case Study House to be sponsored by Royal Dutch Shell which utilizes the by-product of oil extraction, petroleum gas, to produce a zero waste, 100% petroleum based house. The motivation of the Case Study House is to address the housing shortage in Iraq, and demonstrate the capacity of petrochemicals as a building material.

In the Western hemisphere an abundance of trees provides wood, an easy to work with construction material. In contrast, Iraq currently lacks a pervasive natural resource for construction. However, Iraq does boast one of the largest reserves of oil in the world.

During the oil production process natural gas is trapped underground with the petroleum. Because of the pressure change during extraction, natural gas will surface with the crude oil. This type of natural gas is known as associated petroleum gas; it is released as a byproduct or waste product of petroleum extraction. With the right facilities in place these associated gases can be harnessed for energy, and become a feedstock for petrochemical industries.

I am interested in using Basra, Iraq's second most populous city, as a case study for improving the housing need in Iraq. There are several key reasons why Basra will serve as both a strategic and necessary site to develop this idea. Basra's crucial location on the southern tip of Iraq, and at the intersection of the Tigris and Euphrates rivers, has made it Iraq's main port and a gateway into the country. This access to various kinds of transportation through primary ports, as well as rail lines to Baghdad, coupled with a rapidly growing economy stemming from, oil and downstream petroleum based industries, makes Basra an opportune location for a housing intervention.

In conclusion, Iraq has the capacity to produce vast amounts of building material domestically from petroleum gas, a by-product of oil, its primary export. With plastics beginning to emerge as viable building materials in the construction industry, Iraq could likely be on the forefront of making the use of plastics as building materials mainstream.

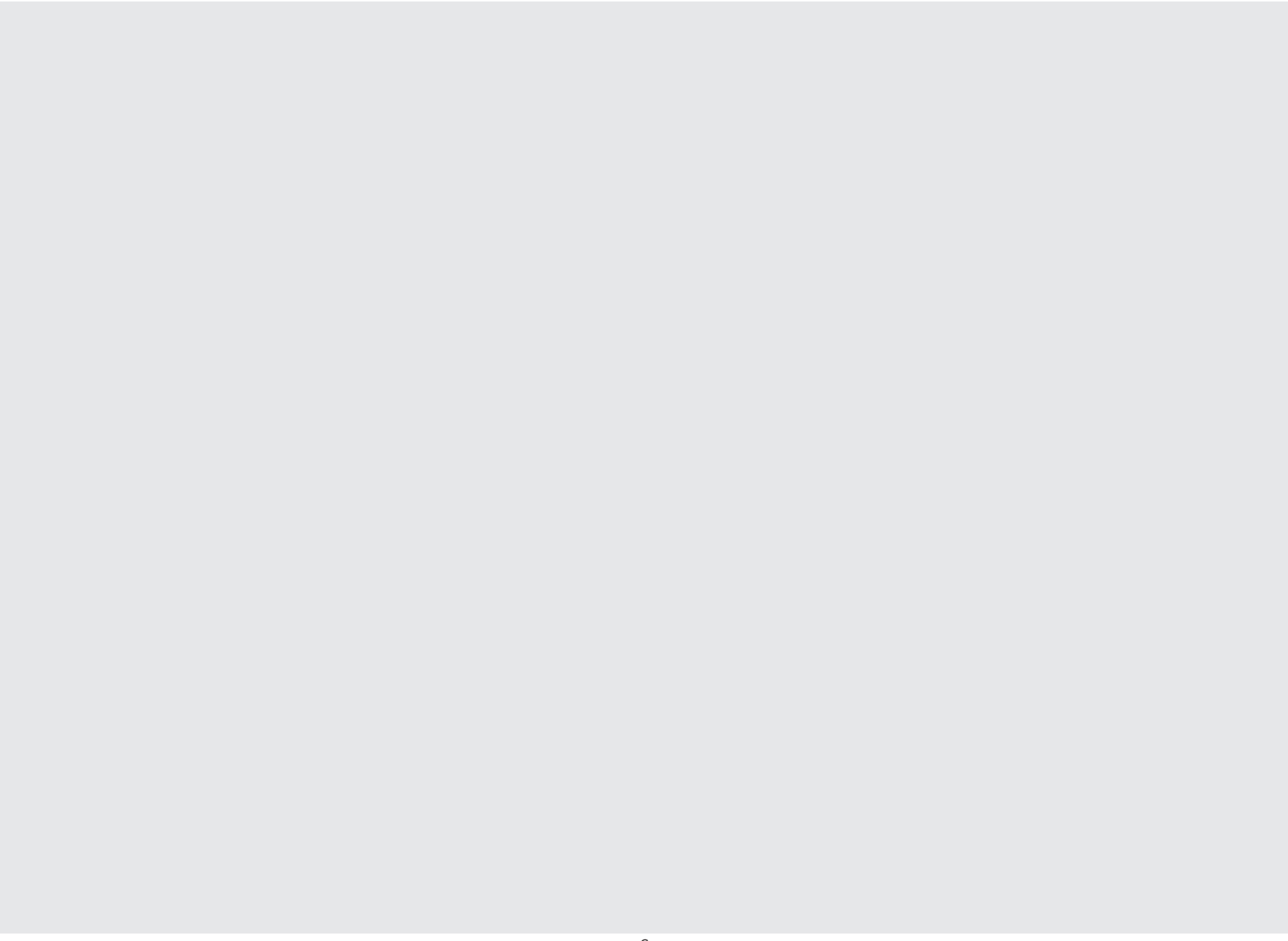

CONTENT

THESIS.....	09
Iraq, War & Housing	11
Resources & Reconstruction	13
By-product = Natural Gas	17
Natural Gas = Petrochemicals	17
5 Advantages of Composites	25
Limitations	25
A // Lightweight	25
B // Dynamic Section	29
C // Long Life Span	31
D // Intelligent Parts	33
E // Increased Capacity	35
MATERIALS.....	37
Petroleum Materials	39
Composites	41
Monsanto House	43
Composite Constraints	45
Material Testing	51
CONSTRUCTION.....	57
Composite Manufacturing	59
Digital Manufacturing	67
Reconfigurable Molds	69
Wall Sections	71
CULTURAL.....	73
Basrah, Iraq	75
Iraqi Domesticity	76
Program	79
Environmental Context	81
DWELLING.....	85
Rapid Assembly	99
Stressed Skin	105
Dwelling	111
Conclusion	120
BIBLIOGRAPHY.....	125

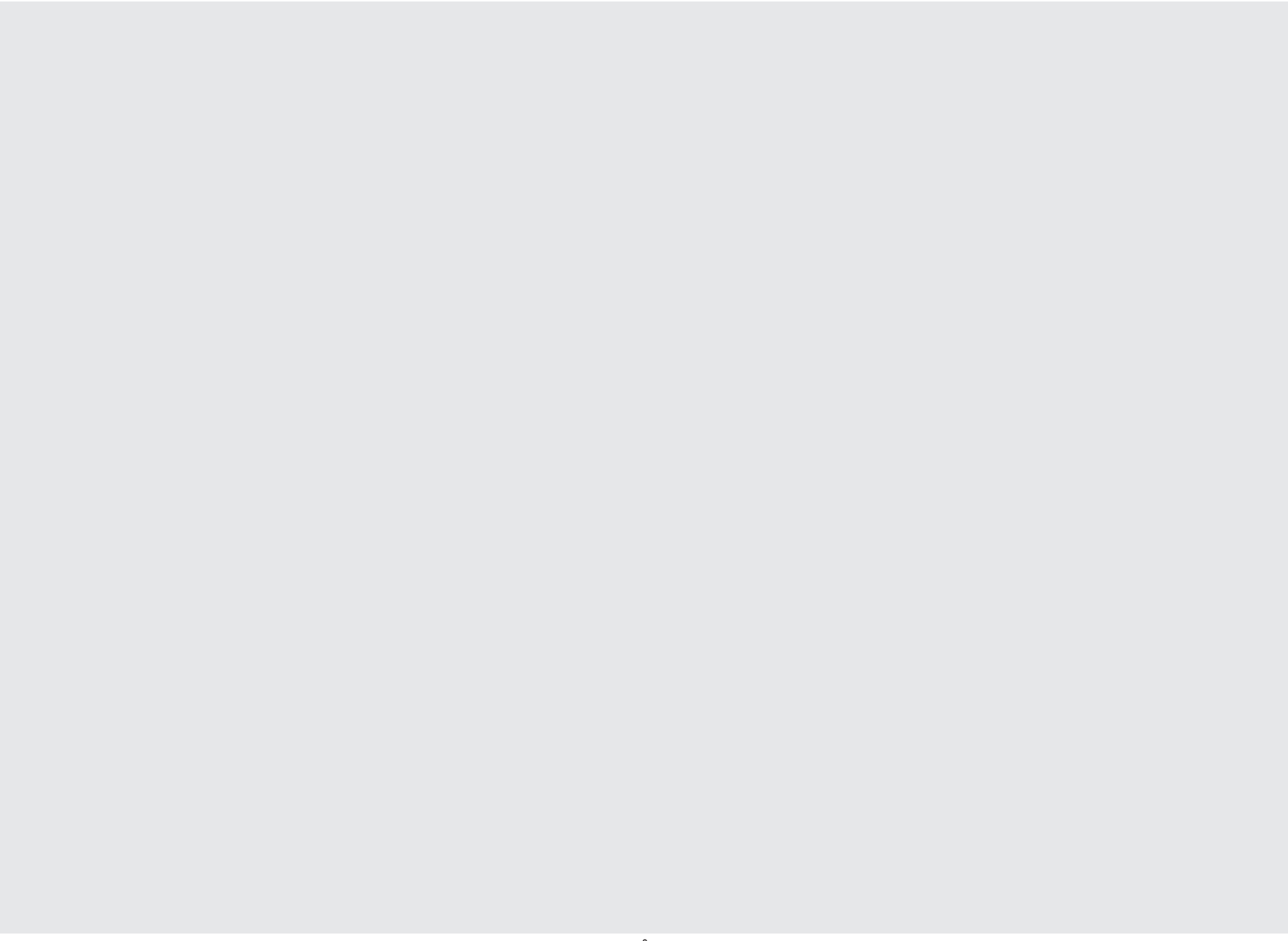

OO // THESIS

BASRA, IRAQ IN RELATION TO OIL FIELDS

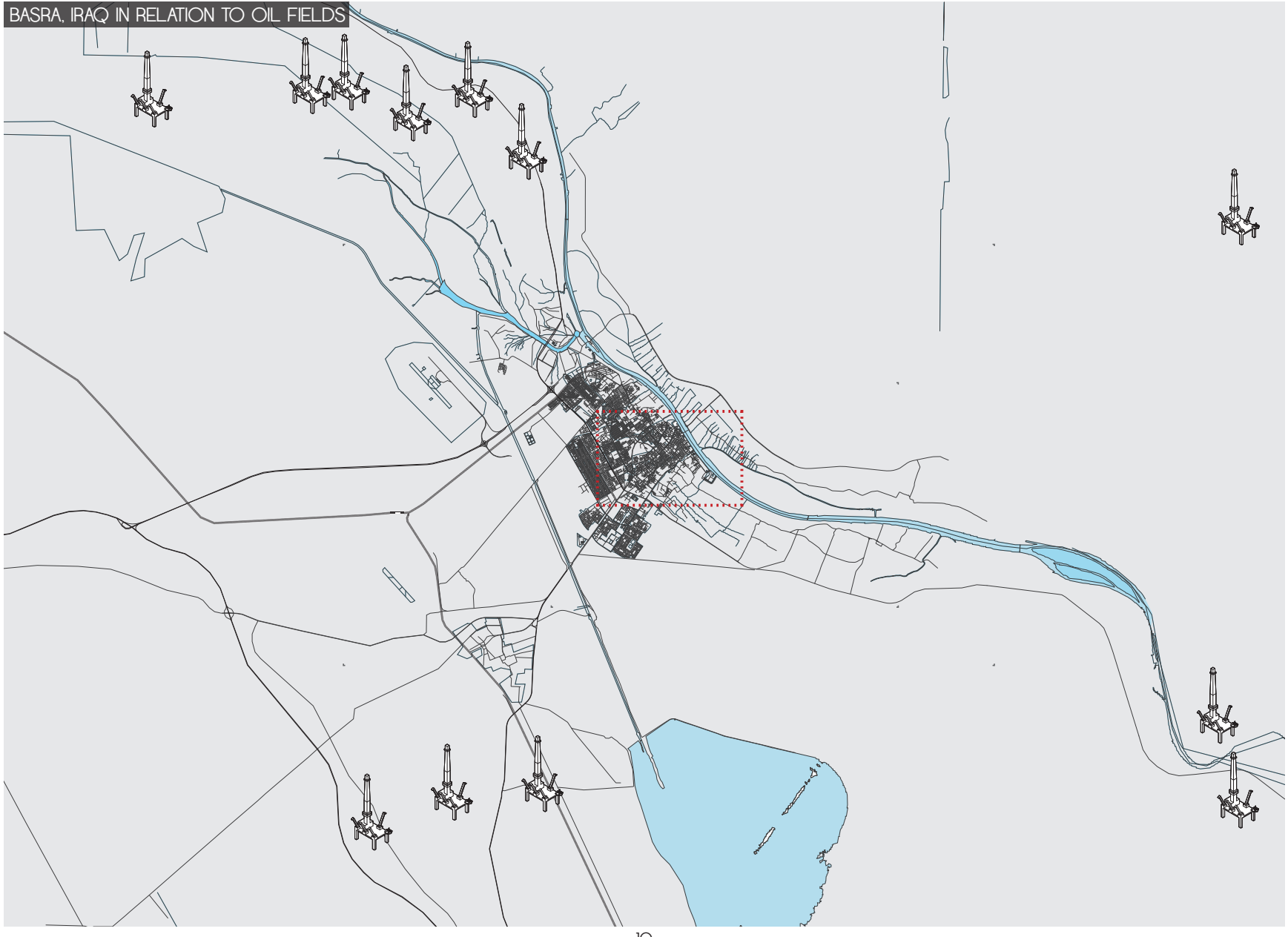

THESIS

Iraq, the cradle of civilization and birthplace of the world's abrahamic religions, abandoned in the despair of destruction with the people left wandering as was once common among their nomadic ancestors. A country with abundant resources, yet incapable of restoring the conditions of return. An imagined utopia of black-gold riches for Western petroleum companies with the ability to restore stability to wandering and displaced Iraqis. A bridge of opportunity between the investment drawn, and those who seek return-- the Monsanto phenomenon in contemporary Iraq-- petrochemical redemption for millions of displaced Iraqis.

The "Monsanto House of the Future", illusionist in scope but innovative in impact. With the intention to demonstrate the potential of petrochemicals as building materials, Goody and Hamilton breached the wall of what was common in construction. Premature in development, its manually intensive nature led to its disregard. Yet, the time to reconsider petroleum based materials in architecture is now.

IRAQ, WAR, HOUSING

On Sunday, December 18th, 2011 the last convoy of American soldiers was pulled out of Iraq, marking the end of an eight year war between the United States and Iraq. This war, known as the Third Persian Gulf War or Operation Iraqi Freedom (2003-2011), was one of three large scale wars which took place in Iraq over the last three decades. The other two being, the Iran-Iraq war also known as the First Persian Gulf War (1980-1988), and

Operation Desert Storm also referred to as the Second Persian Gulf War (1990-1991). Additionally, during this time span Iraq saw many smaller conflicts, revolts, and acts of sectarian violence. Altogether, the various wars and conflicts have left Iraq in a state of complete disarray, characterized by war torn buildings, piles of rubble, lack of infrastructure, and outdated social services.

The post-war destruction of the housing sector, coupled with a preexisting need, has created an extreme housing shortage in Iraq. Baghdad, as both the capital and largest city in Iraq, has been the main target of international aid and reconstruction efforts. Though Baghdad has seen mild improvements in the need for housing, the rest of the country has been largely neglected, with very few improvements in the housing sector. According to the Internal Displaced Monitoring Center, Iraq has over 2.3 million internally displaced peoples (IDP) currently within its borders, with 900,000 of those coming from conflicts before the 2003 war¹. Initial reconstruction efforts have been made, yet they have largely targeted high income, wealthier classes, which make up a minority of the Iraqi population. According to the Republic of Iraq Ministry of Construction and Housing, over two million dwellings are needed by 2016 predominantly to serve the lower and middle income communities (UN Habitat 2010)². In addition to IDPs, many refugees are returning to Iraq following the conclusion of the war, adding another community in dire need for housing.

¹ Unknown. Internally displaced population. Internal Displacement Monitoring Centre. 2011. Web. 2012.

² Republic of Iraq Ministry of Housing. Iraq National Housing Policy. UN Habitat. 2010. Web. 2012.

THE UNITED STATES IN RELATION TO NATURAL FORESTS



RESOURCES & RECONSTRUCTION

Among the many housing challenges facing Iraq, the most formidable are: the absence of a department of housing and urban development, infrastructure and service backlogs, and the deficiency of building materials.³ The lack of building materials has tremendously hampered the reconstruction and housing development efforts. In standard Western construction, there is an abundance of trees and sustainably certified forests, which provide a renewable, easy to work with construction material. Wood frame homes can be constructed within weeks and require very little equipment. In contrast, Iraq currently lacks an abundant natural resource for construction. In a survey conducted by the United Nations Habitat, called the Iraq Market Housing Study (IMHS) Builders Survey, contractors were asked to cite three primary problems with the housing market. Of those interviewed "roughly 81% of the builders indicated that availability and high prices of building materials caused them the greatest problem."⁴

Most buildings in Iraq are made from concrete and concrete blocks. However, the use of concrete in Iraq has faced many challenges over the last decade. From the 1970s to the 1990s, Iraq was a large exporter of cement; unfortunately, most of the cement manufacturing plants were destroyed during the war. Currently, Iraq is being forced to import large amounts of its cement from Turkey

³ The third aspect of the housing challenges is the only one that can be addressed through an architectural solution and therefore will be at the heart of the thesis.

⁴ Republic of Iraq Ministry of Housing and Construction Iraq Housing Market Study, Rep. PADCO, 2006. Web, 2012.

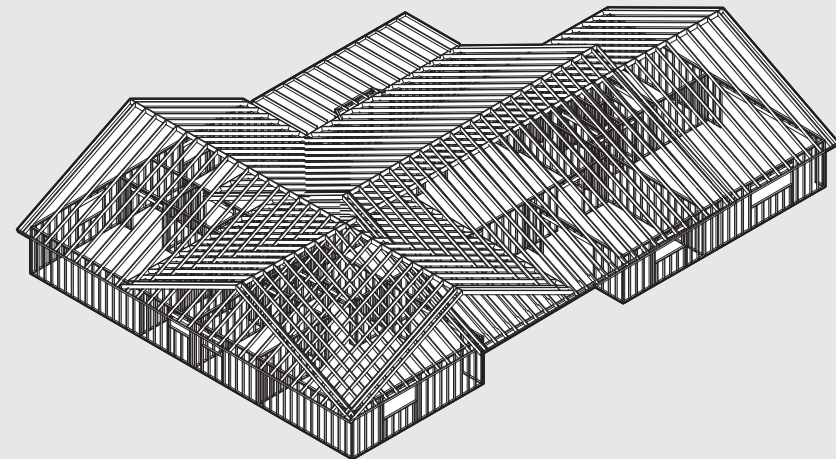

CONCRETE CONSUMPTION IN IRAQ

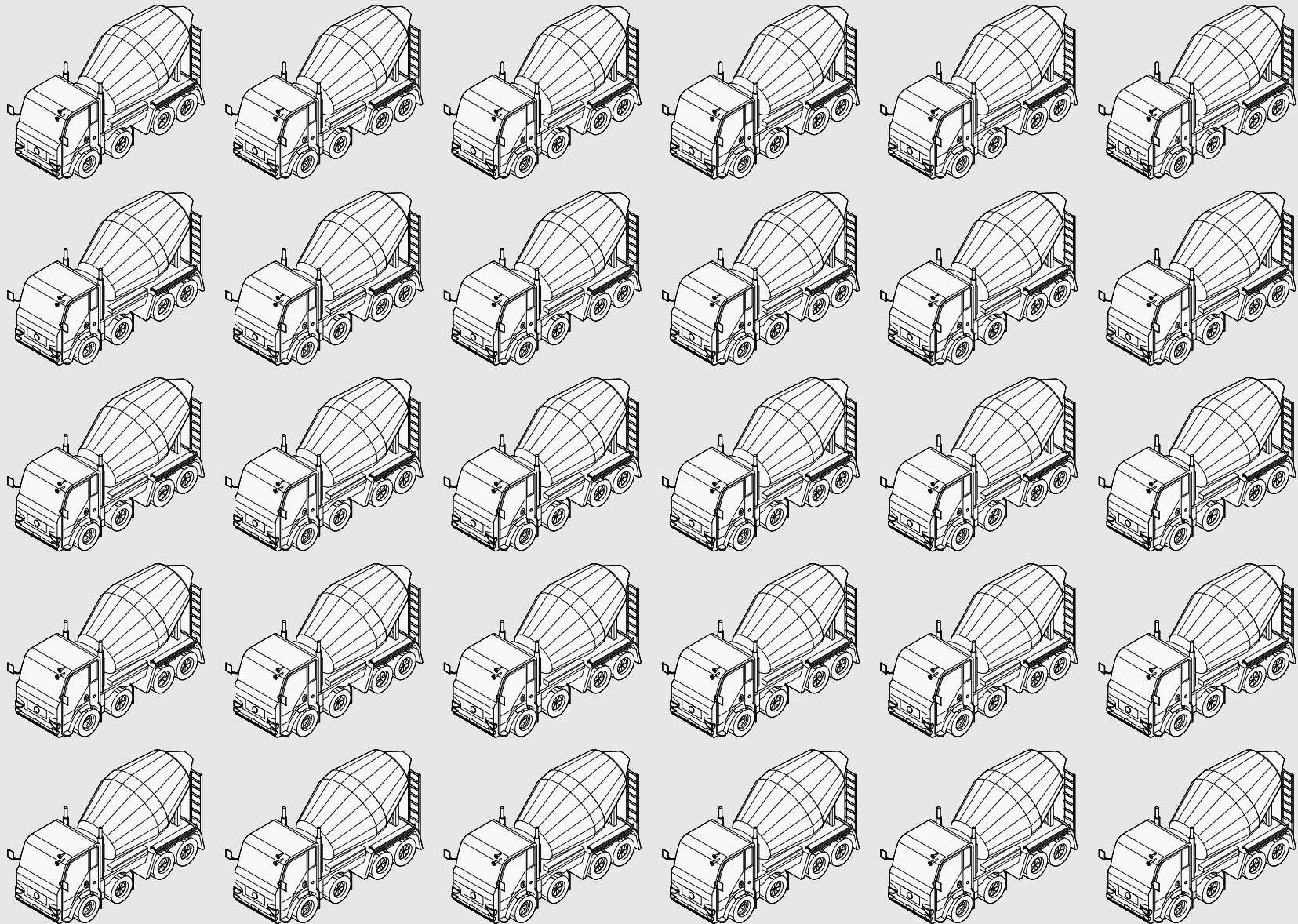

and Iran in order to supply the only building material used in Iraq, concrete.

In addition to the shortage of concrete, constructing homes from concrete blocks is a slow and laborious process. Building with relatively small, heavy unit concrete blocks (2m x .4m x .2m) which require additional concrete for infill, as well as steel rebar in order for the wall to be load bearing, has resulted in homes that take months to construct. In order to avoid cracking, concrete block homes require very large foundations to minimize movement. Lastly, all insulation and services such as electrical and plumbing, must be added outside the wall cavity because unlike wood stud construction, they cannot be embedded into the wall system.

Although Iraq lacks the forests which allow for the rapid stick frame construction common in the West, Iraq boasts one of the largest oil reserves in the world. In recent years, oil production has surged quickly becoming the country's largest commodity, a trend that appears to be increasing. In fact, Iraqi Oil Minister, Hussain al-Shahristani wanted to boost "oil production from its current level of some 2.4 million bpd to 10 million-12 million within the next decade," which would exceed what both Saudi Arabia and Russia are currently producing.⁵ Because of the destruction associated with the war, as well as decades of conflicts and sanctions, Iraq has yet to fully capitalize on its natural resource and lead the oil market.

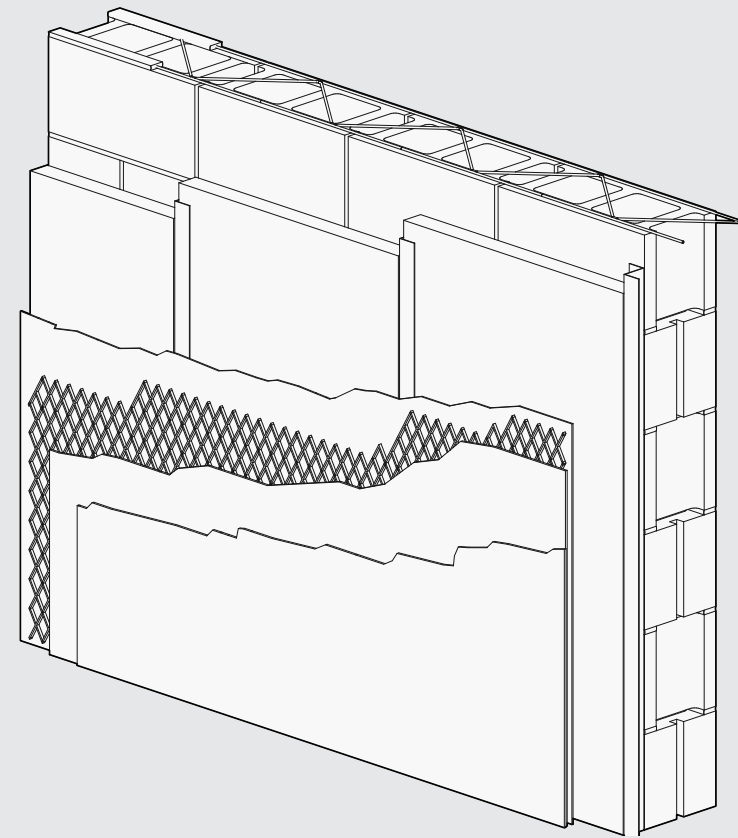

⁵ Unknown. Iraq Eyes OPEC Top Spot, Seeks India Pact. United Press International. 2011. Web. 2012.

OIL AND ASSOCIATED GAS PRODUCTION

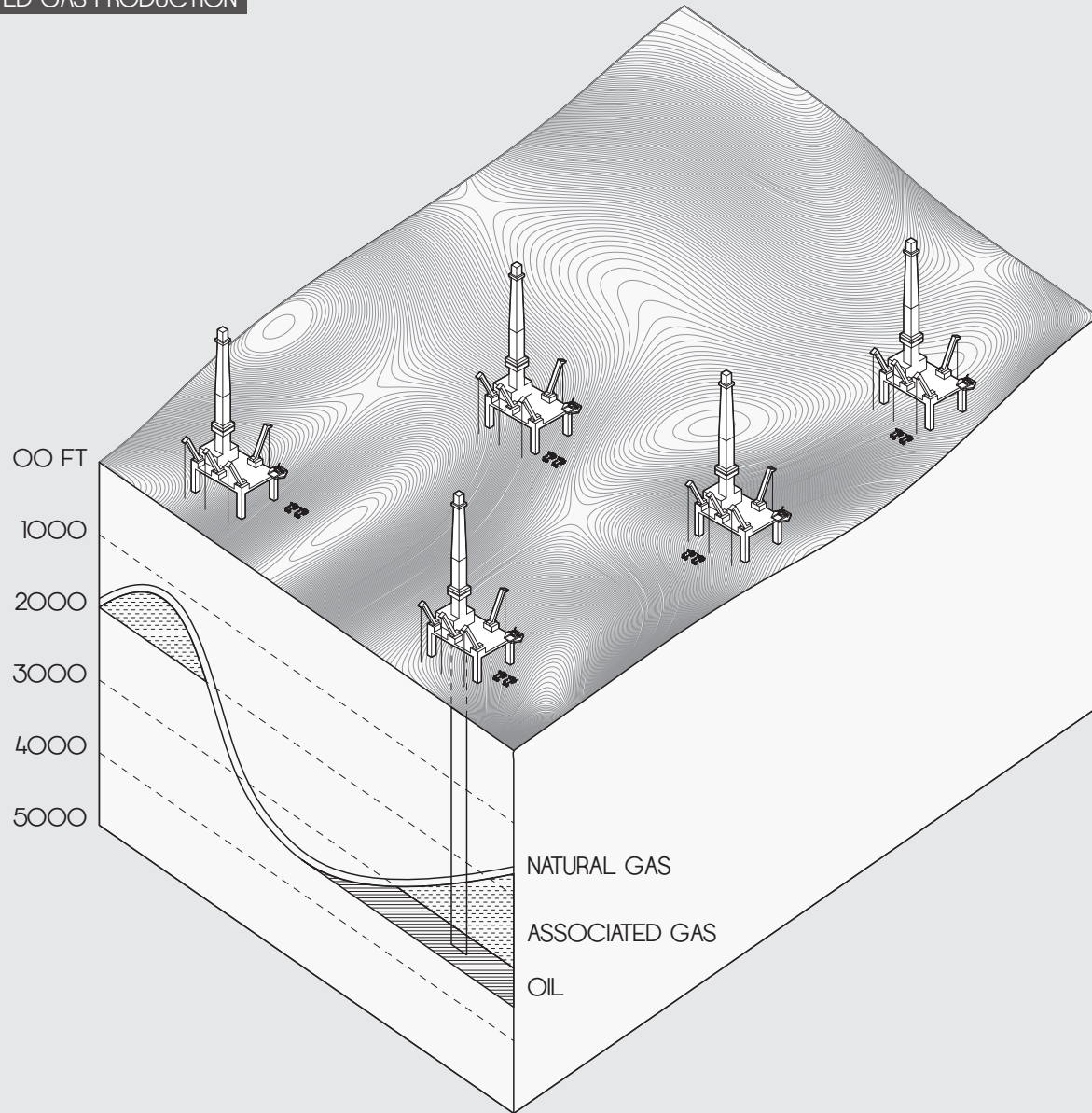

BY-PRODUCT = NATURAL GAS

Petroleum and natural gas are both trapped underground during oil production; during the extraction process the pressure change allows natural gas to surface with the crude oil. This type of natural gas is known as associated petroleum gas, solution gas, associated gas, or flare gas. Associated gas is released as a byproduct or waste product of the petroleum extraction process. Without the correct infrastructure in place the gas is typically set ablaze; this is known as flaring.

The flaring of associated gas is a waste of a valuable natural resource. With the correct facilities in place, these associated gases can be harnessed for energy, and become feedstock for petrochemical industries. In Iraq, the necessary infrastructure is just beginning to be developed in an effort to utilize these associated gases.

NATURAL GAS = PETROCHEMICALS

When the proper infrastructure is in place to manage associated gases, they can serve as feedstock for a very exciting and dynamic downstream petrochemical industry. Petrochemicals are petroleum based chemical products which can be used to create, among many other things: elastomers, resins, fibers and plastics. These associated gases have drawn attention from some of the big name oil companies. According to the Vice President for New Business Development and Ventures at Shell, Lain Lo, "Iraq is a very interesting future possibility because it has large oil reserves, and when you produce that there will be associated gas that comes with it... [and] clearly feed-

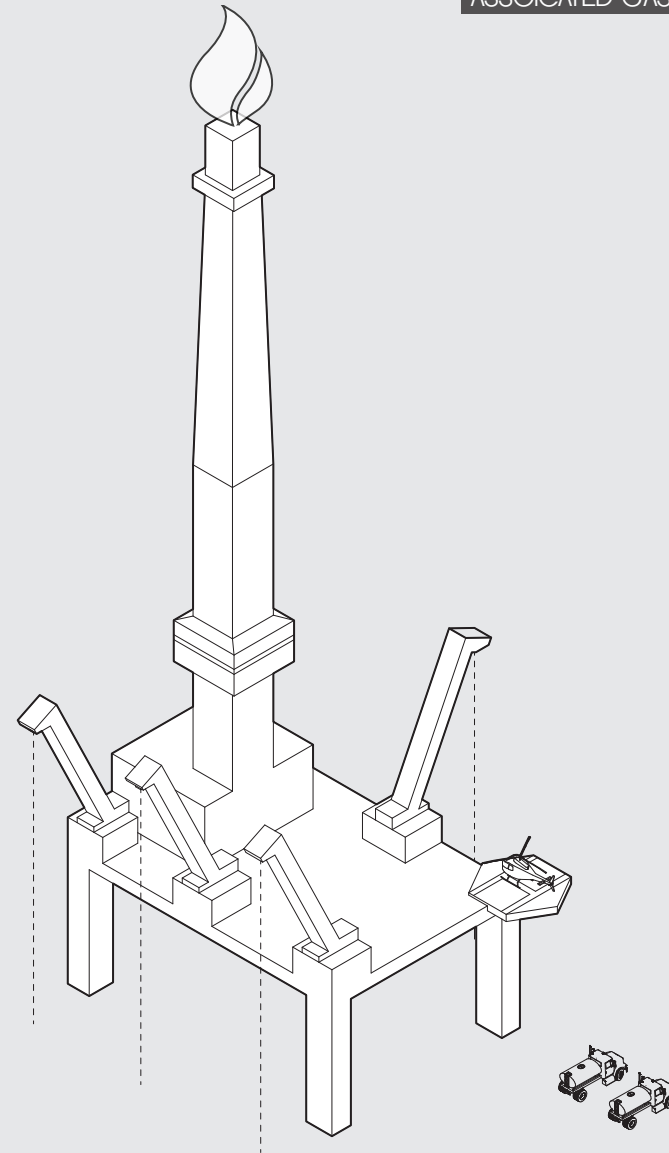

O1 // OIL EXTRACTION AND PETROLEUM REFINERY

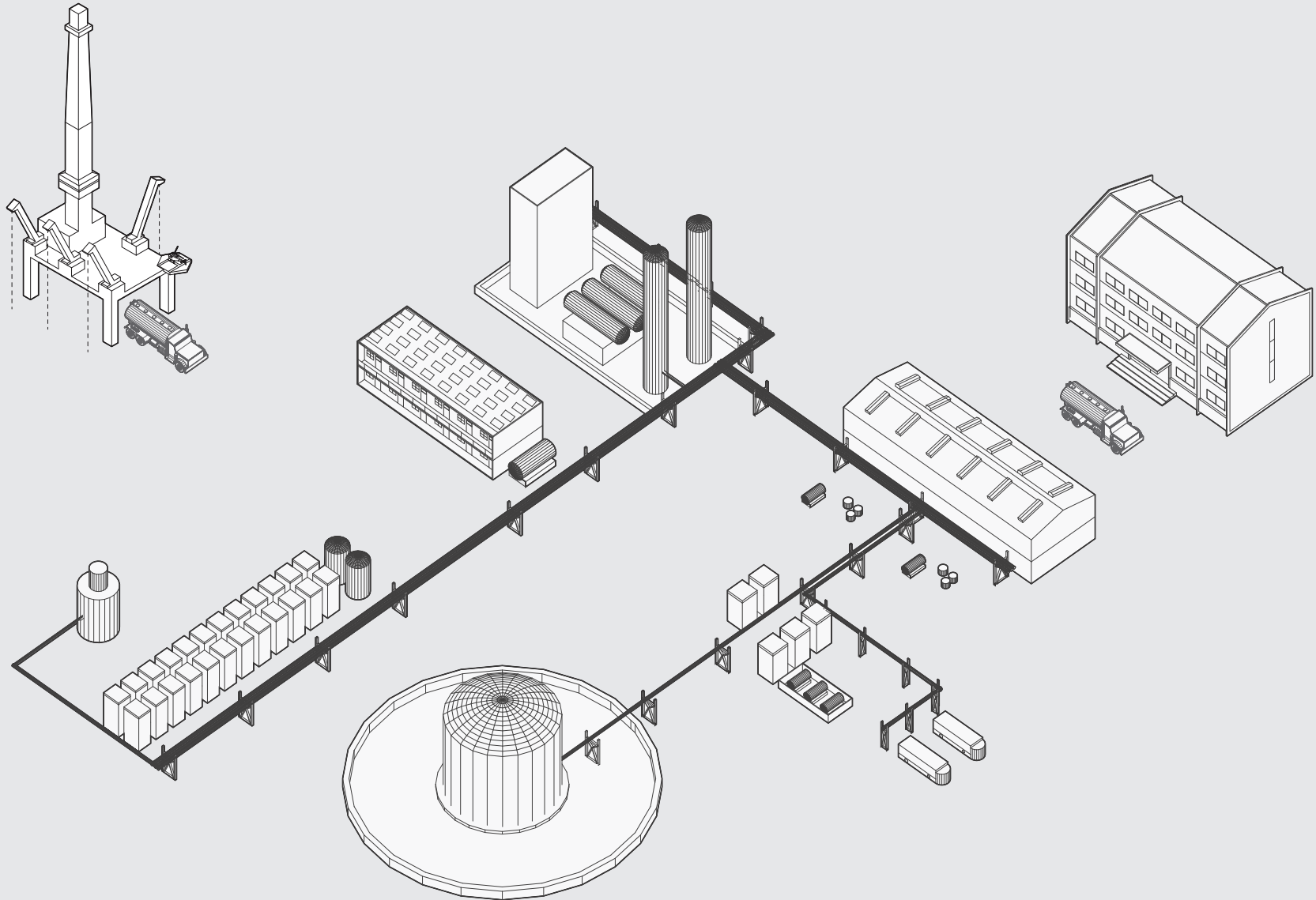

stock for petrochemicals.”⁶

In 2011, Royal Dutch Shell won a large contract to begin oil production in southern Iraq betting out many other big oil companies. The contract, for over 172 billion US dollars includes an agreement by Shell to “capture as much as 700 million cubic feet of associated gas a day from the giant oilfields in the south” with the intention of building “a liquefied natural gas plant in Iraq once domestic gas needs are satisfied” to then channel “gas into a downstream industry ... [and] utilize the gas surplus.”⁷

SHELL SOURCE : <<http://logos.wikia.com/wiki/File:Shell.png>>



1900



1904



1909



1930



1948



1955



1958



1961



1971



1995



1999

The large petrochemical plant will redirect hundreds

⁶ Unknown. Shell Plans Venture to Expand Presence in Iraq. The National. 2011. Web. 2012.

⁷ Unknown. Shell Plans Venture to Expand Presence in Iraq. The National. 2011. Web. 2012.

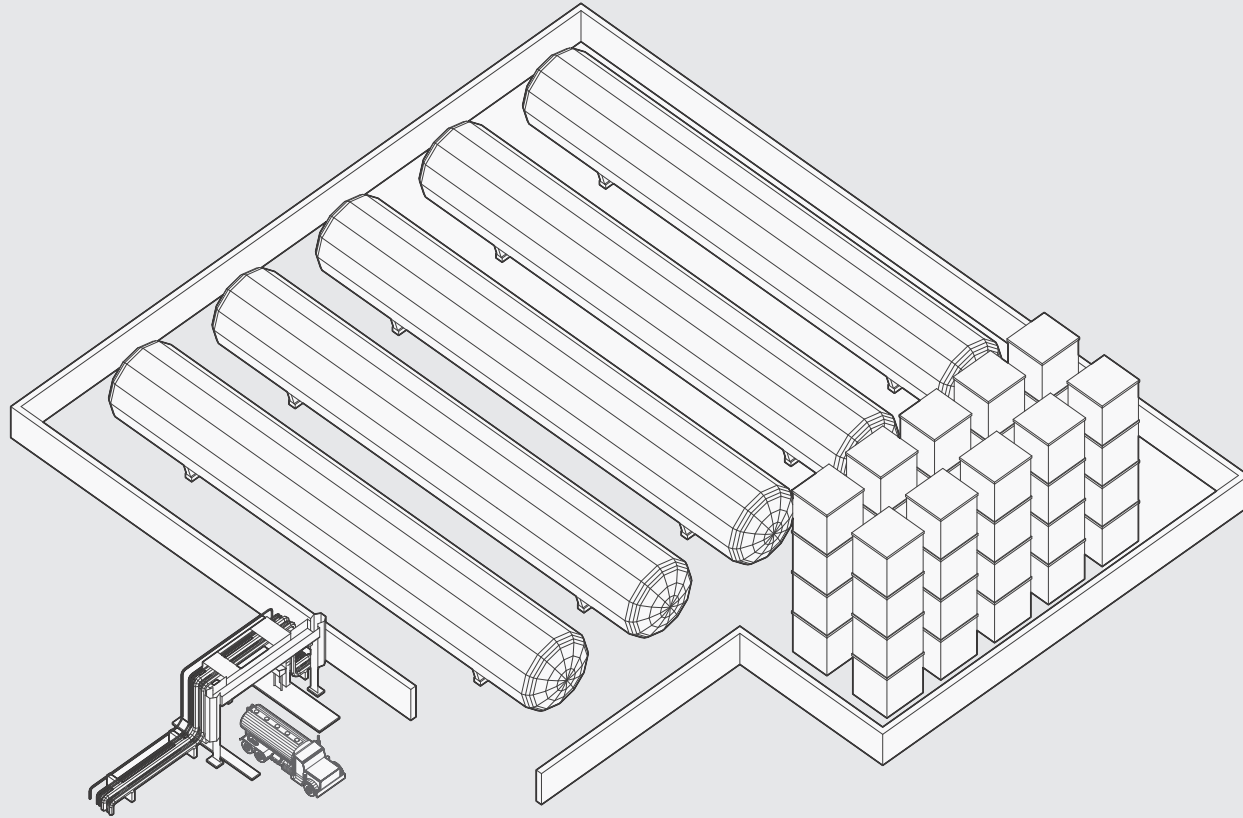

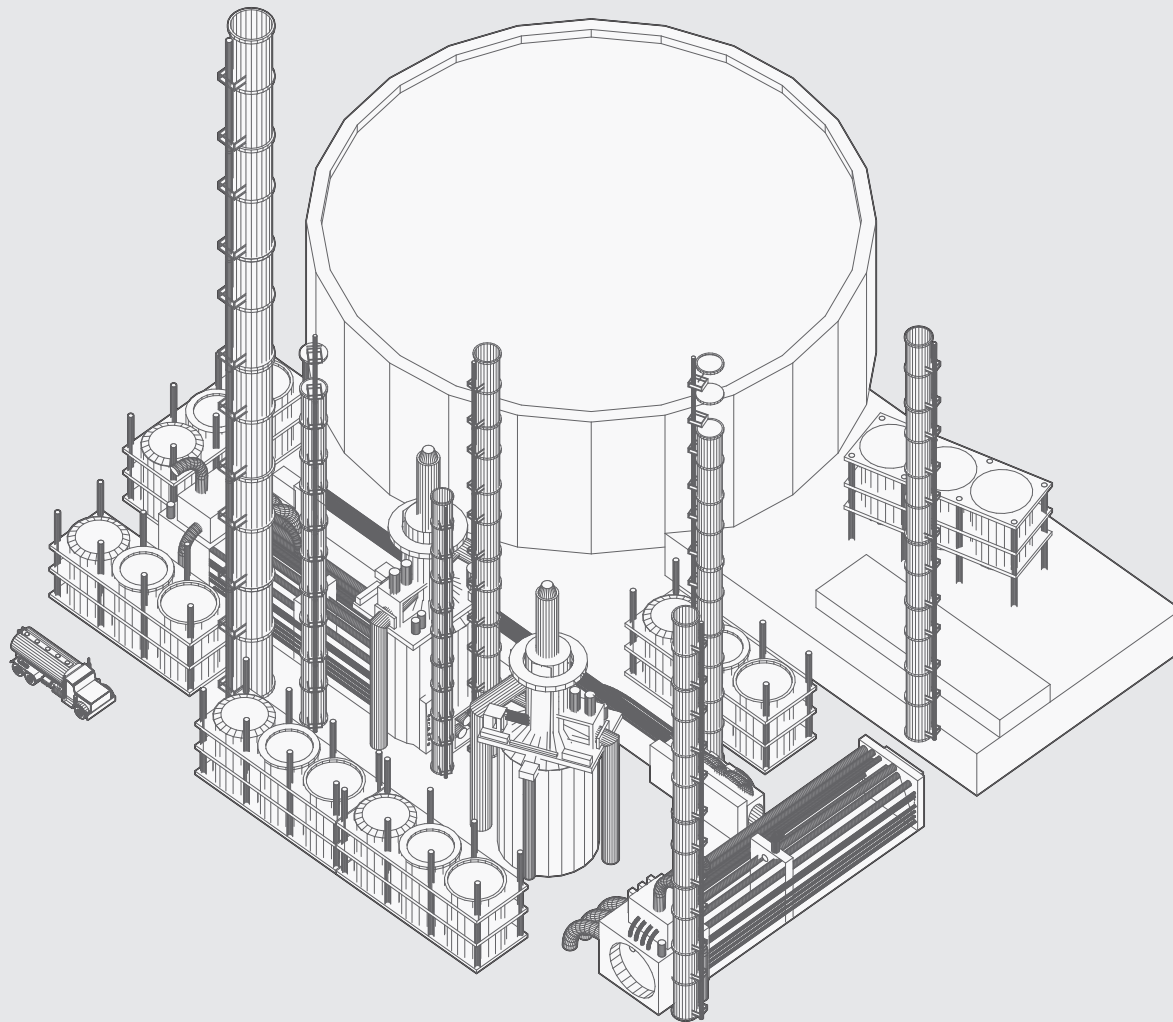

IRAQ IN RELATION TO PETROLEUM NATURAL RESOURCES

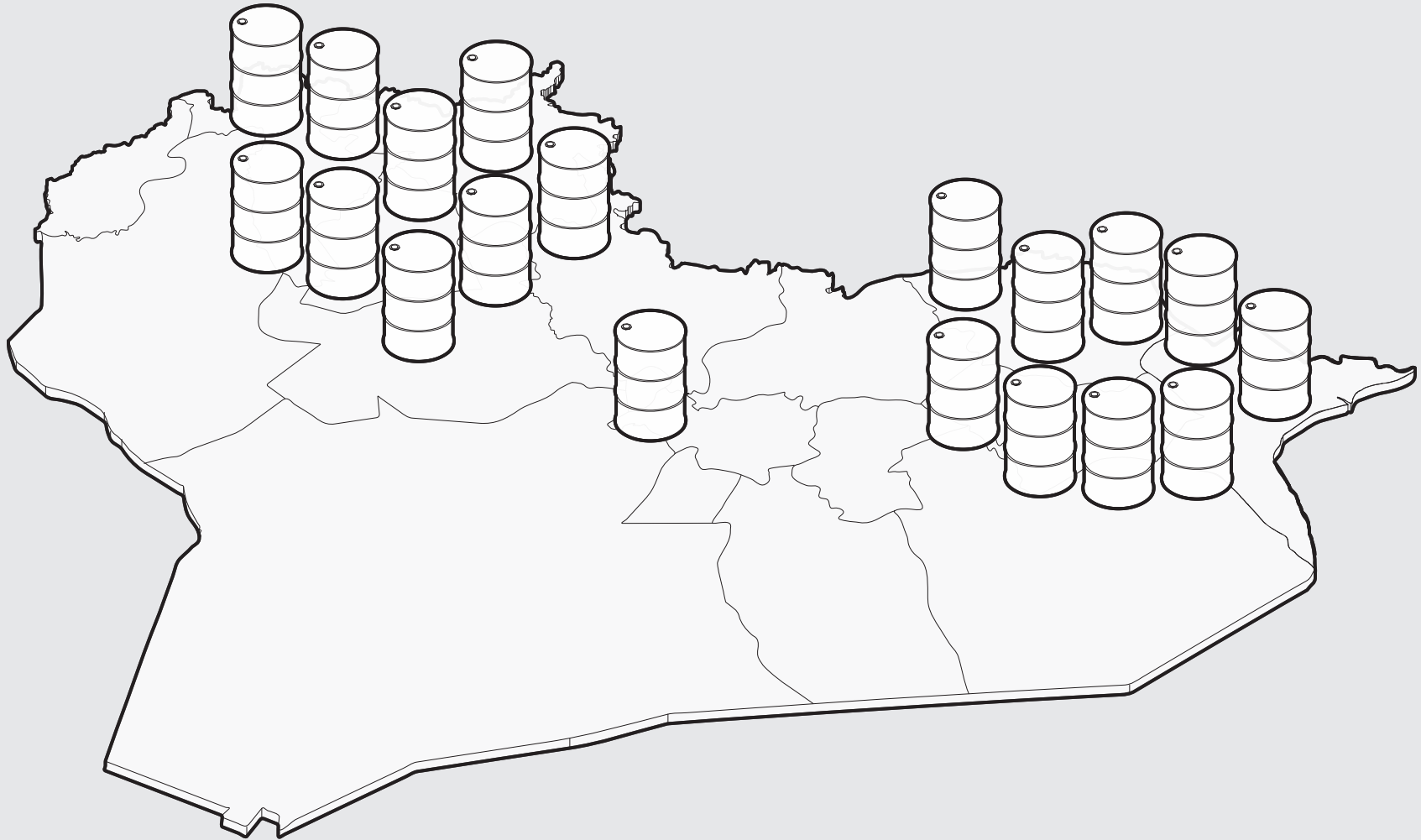

of millions of cubic feet of associated gas from flaring, and rapidly develop a large petrochemical and plastics industry in Iraq. Learning from their neighboring Middle Eastern countries, such as Saudi Arabia, which is one of the world's top producers of plastics, Iraq will soon be at a place where it is producing large quantities of plastics, both for domestic use and exportation. ⁸

OIL = PETRO HOUSE

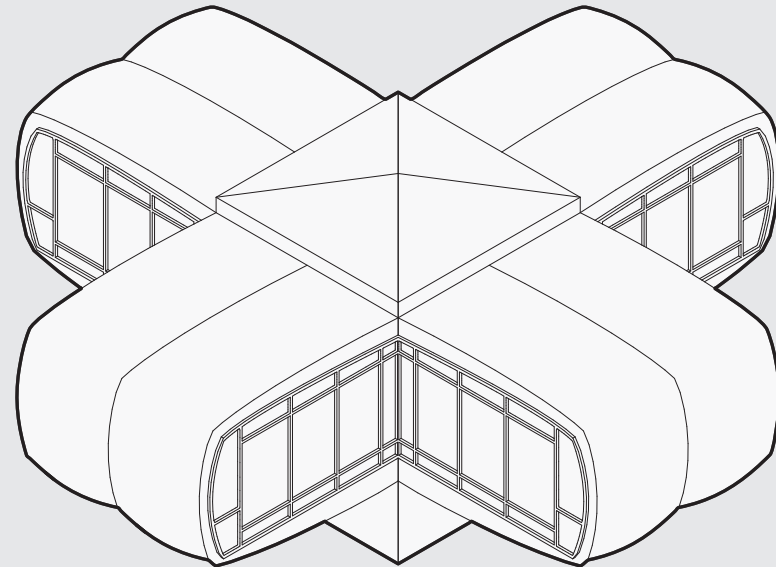
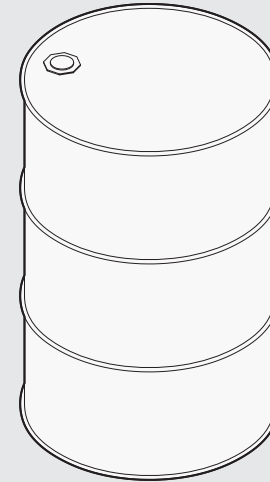

⁸ David Morgan. Iraq Petrochemicals & Plastics Sector. Global Arab Network. 2009. Web. 2012.

WOOD STUD WALL // WEIGHT 840 LBS

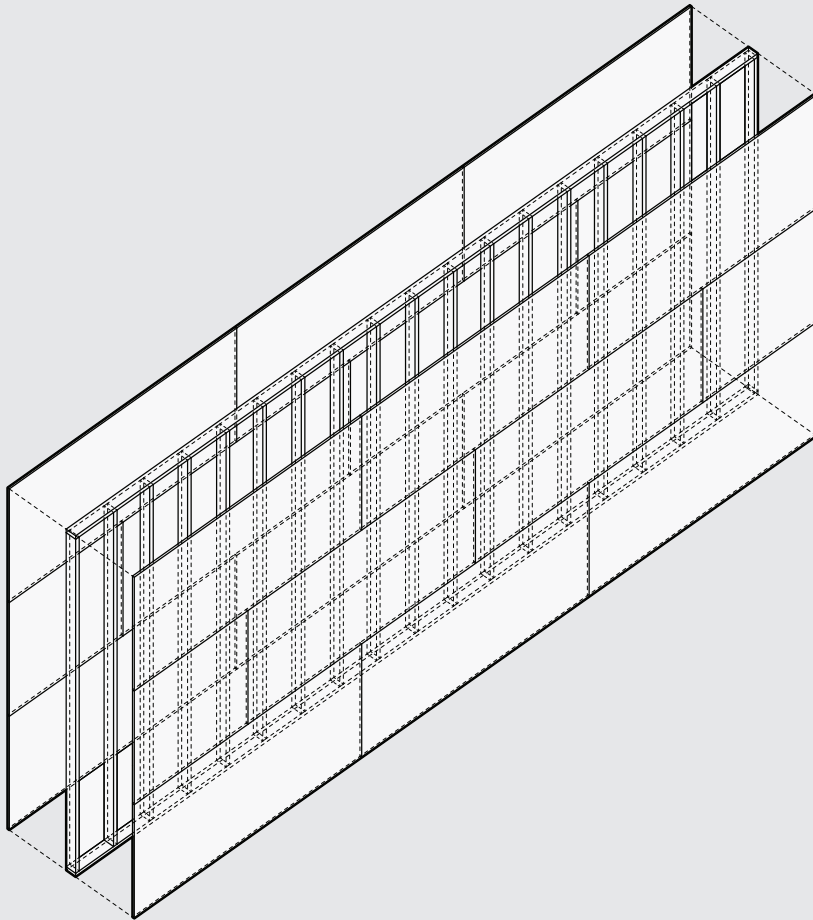

CMU WALL // WEIGHT 5800 LBS

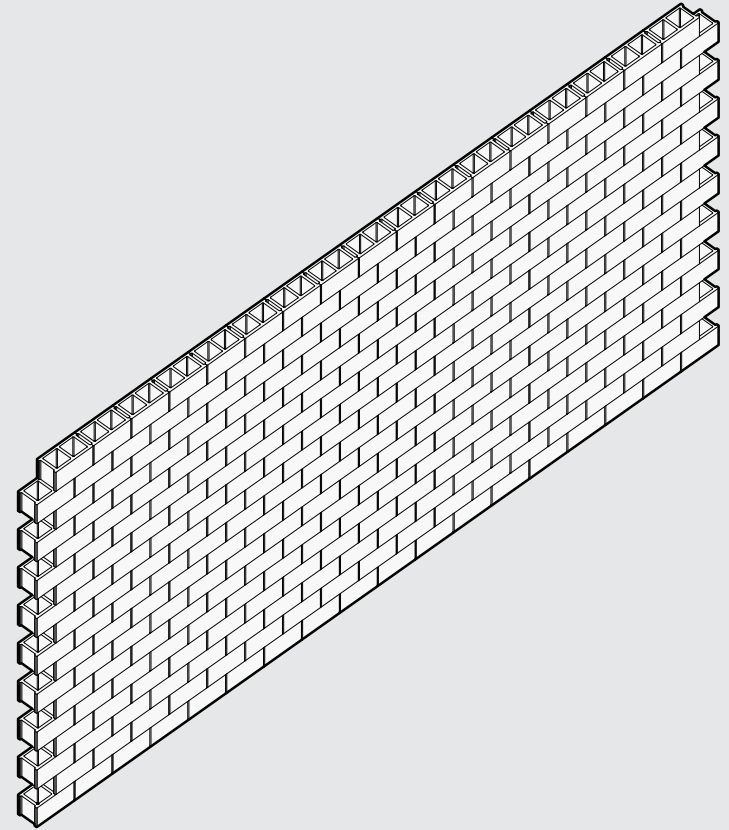

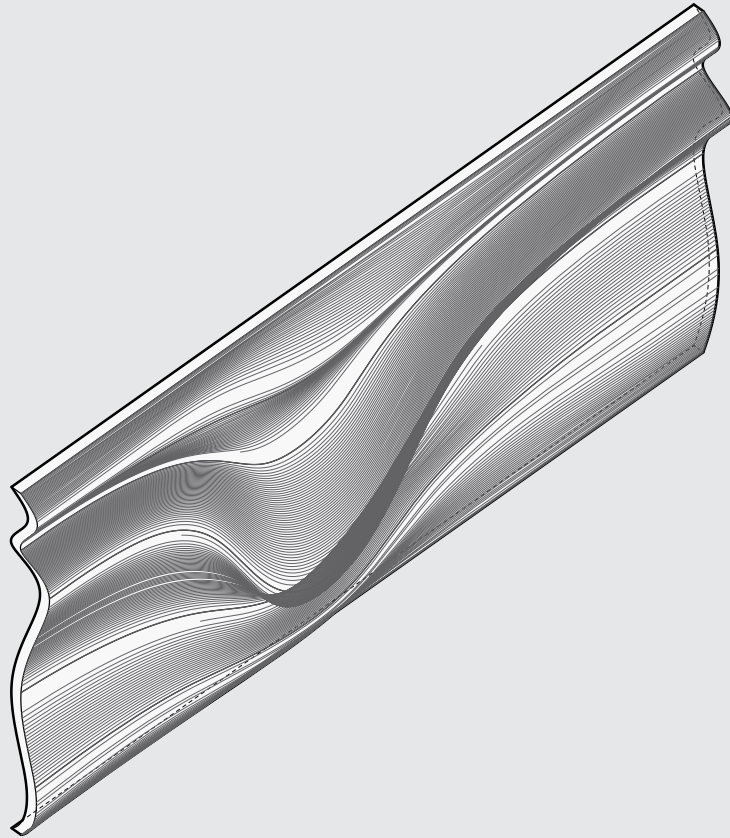

5 ADVANTAGES OF COMPOSITES

There are many advantages and some limitations when it comes to using petroleum based materials for building. They would result in a radically different type of dwelling, one that has social, cultural, economic and urban consequences and architectural potentials. I will discuss the limitations and key advantages of how the use of composite materials impact architecture.

LIMITATIONS

The main limitations on plastic becoming a viable building material stem from the many misconceptions that have been harbored through decades of previously unsolved problems. In the past, plastics were stereotyped and stigmatized as “cheap” and “disposable” and overtime have been bound to early skepticism stemming from high toxicity, consistent off-gassing, and poor UV ray resistance. However, in recent years composites and plastics have evolved quickly and through consistent use and research many of the previous concerns have become obsolete. We are constantly coming up with new innovative solutions to plastic’s shortcomings, such as the use of low VOC resins that are non-toxic.

A // LIGHTWEIGHT

Plastic materials boast an extreme strength to weight ratio, resulting in unparalleled thinness and lightweightedness. This component allows for a house to be rapidly assembled, on the order of days and with minimal equipment.

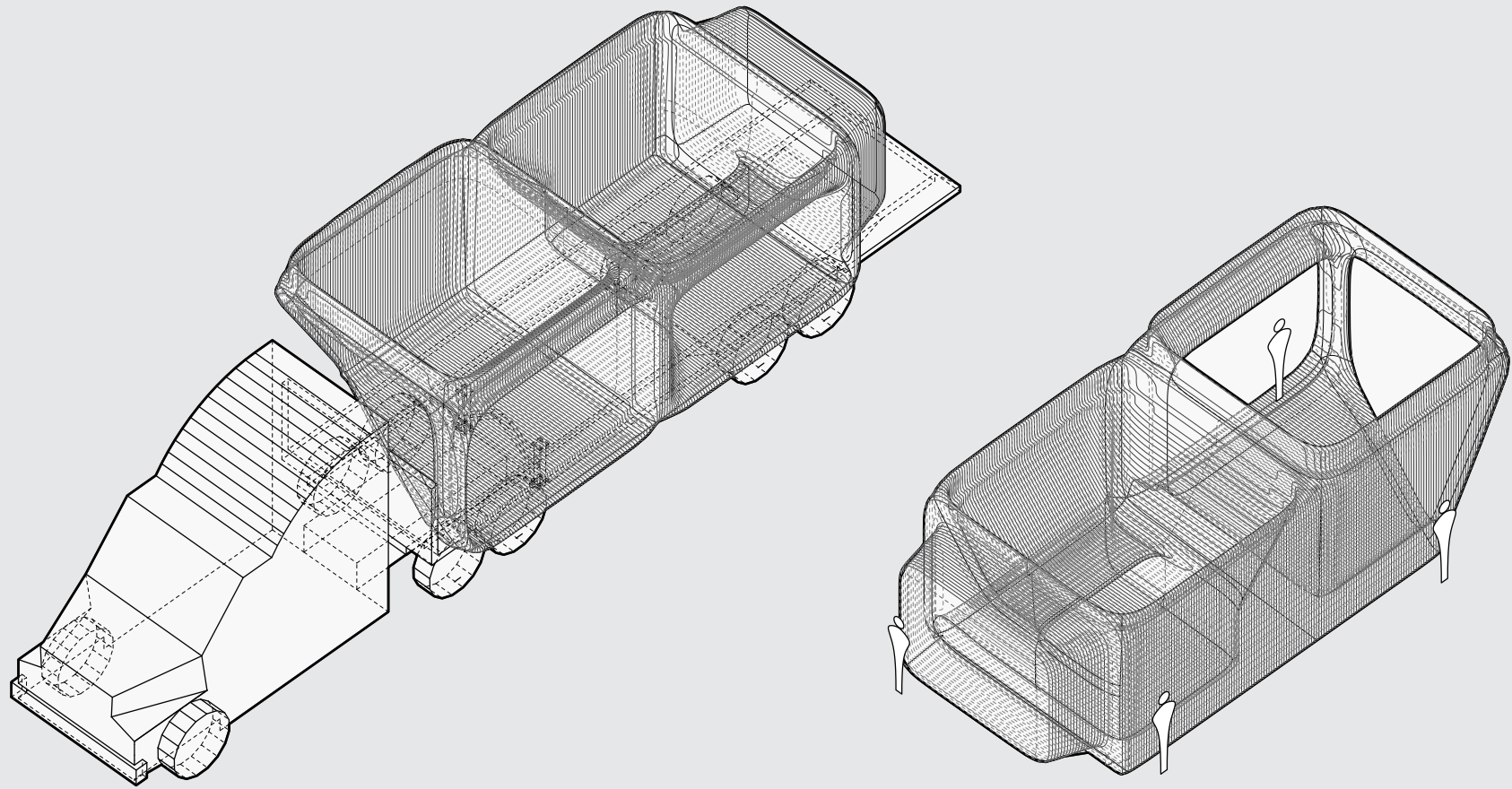

ON SITE PLACEMENT AND TILT UP

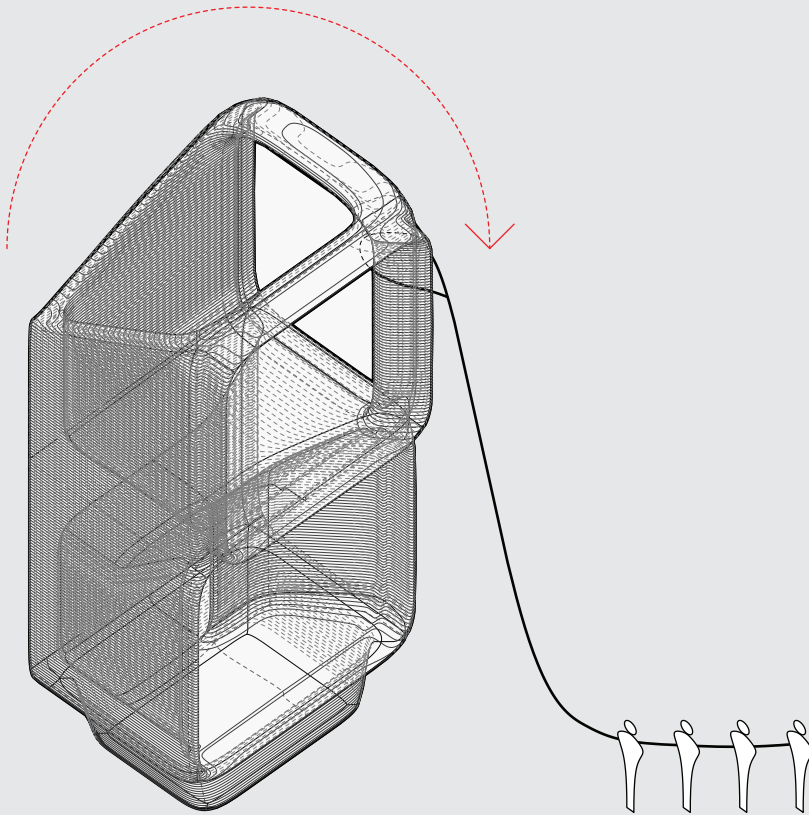

This lightness also simplifies the transportation of materials to the building site, which means an entire house can be brought to the site at one time and tilted up.

The magnitude of the weight difference between using plastics and more typical building materials is incomprehensible. A typical wood stud wall is twelve feet high by twenty four feet wide, weighs approximately 840 lbs, it is made of 2 x 4 wood studs on 16 inch increments, and clad in plywood sheathing and drywall. In comparison a typical CMU wall of the same dimensions weighs approximately 5800 lbs, this does not include the rebar or infill concrete that would be required to make it structural and load bearing. In contrast, a composite wall, again of the same dimensions, would weigh a few hundreds of pounds. The wall is made up of three to seven composite layers on both sides of a few inch thick foam core. However, until we begin to build with these new materials it is impossible to fully understand the implications that such reduced weight may have on architecture and construction.

Architectural features that have been discouraged if not impossible to accomplish with steel, concrete and wood, can now be achieved through plastic. For example, through the light-weighted feature of plastic, a structure could be cantilevered five times more than steel, while still reducing weight. There are also newfound possibilities with this dramatic decrease in weight, allowing foundations to become much less environmentally altering.

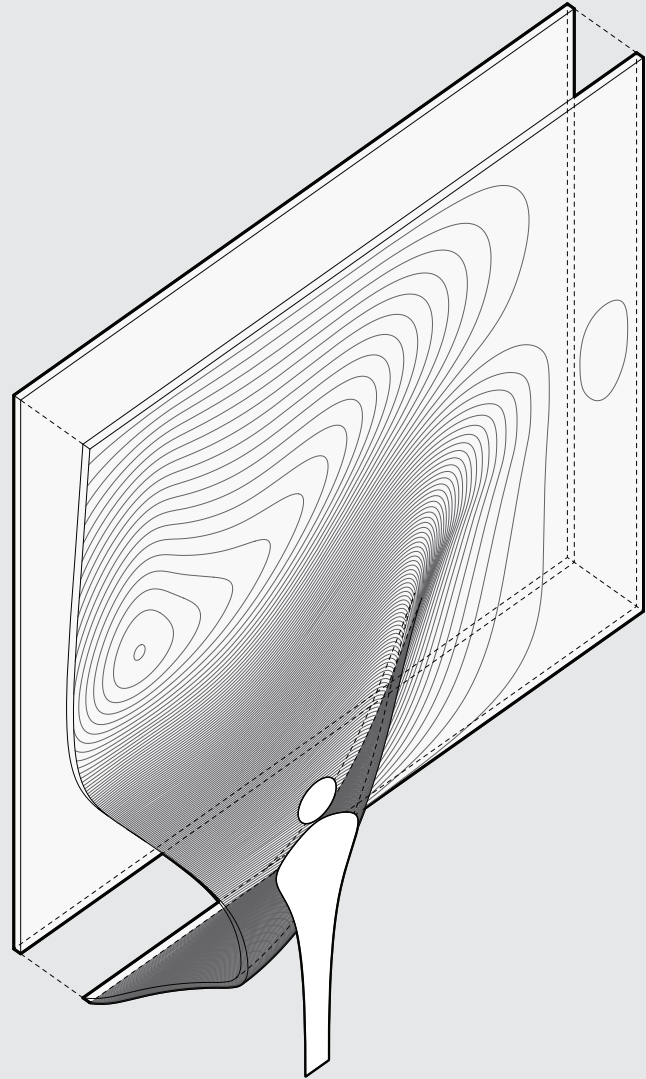
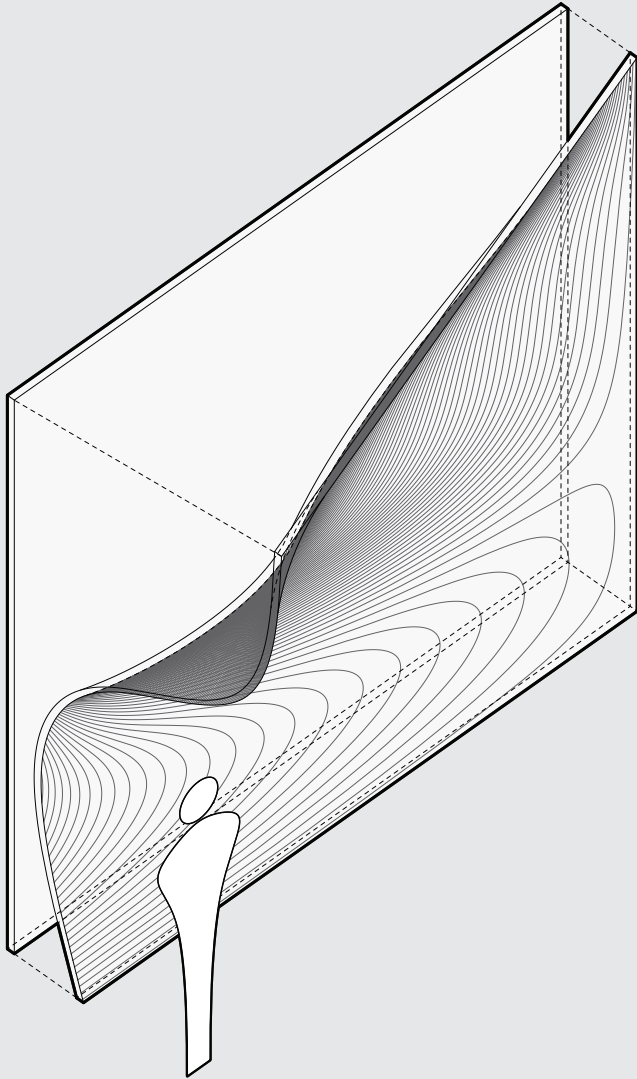

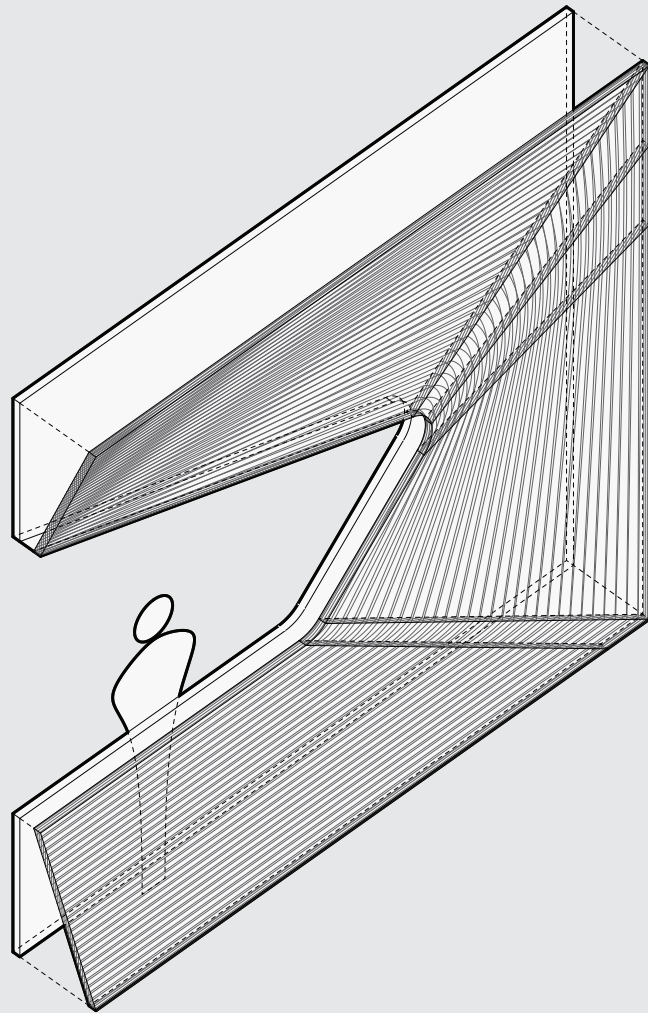

B // DYNAMIC SECTION

Composite materials present the opportunity to collapse many building systems into a single dynamically changing wall section. To understand the dynamic section one must begin by understanding the nature of composites. First, forces are transferred through a skin; typically the skin is separated by a core forming an interior skin, and an exterior skin. The core can be made of a number of materials; the most common types are light materials such as an aramid honeycomb, or an expanded polyurethane foam.

The strength of the composite is in direct relation to the thickness of the core. As the interior and exterior skin are held apart, the core works to transfer a load between the two skins. When the interior skin goes into compression, the exterior skin is put into tension. Composites remain extremely strong in both tension and compression. The core creates a radius of curvature between the two skins, the greater this offset, the stronger the composite.

In addition, the cavity created by the core, creates an exciting potential. This delamination of the interior and exterior allows for a thickening and thinning of the wall section and creates opportunities for apertures, storage and integrated joints.

2012

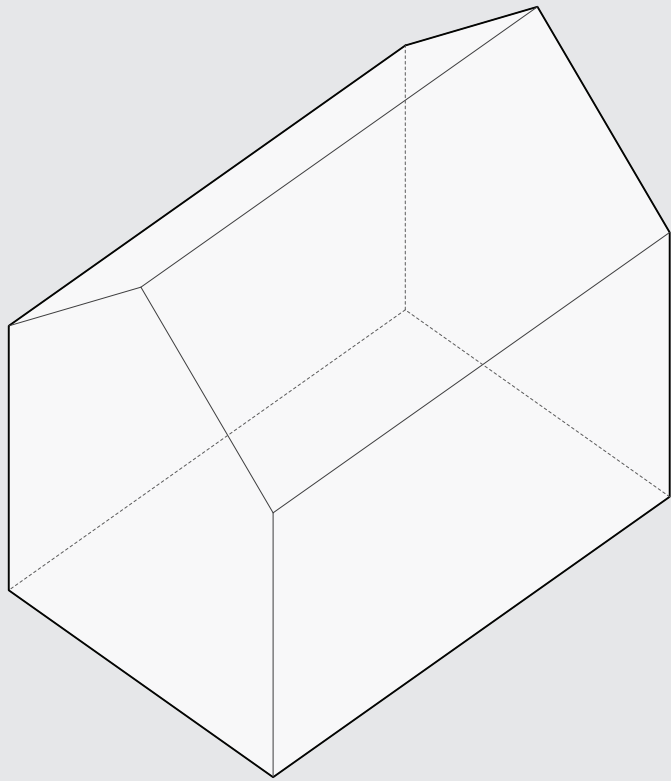

2062

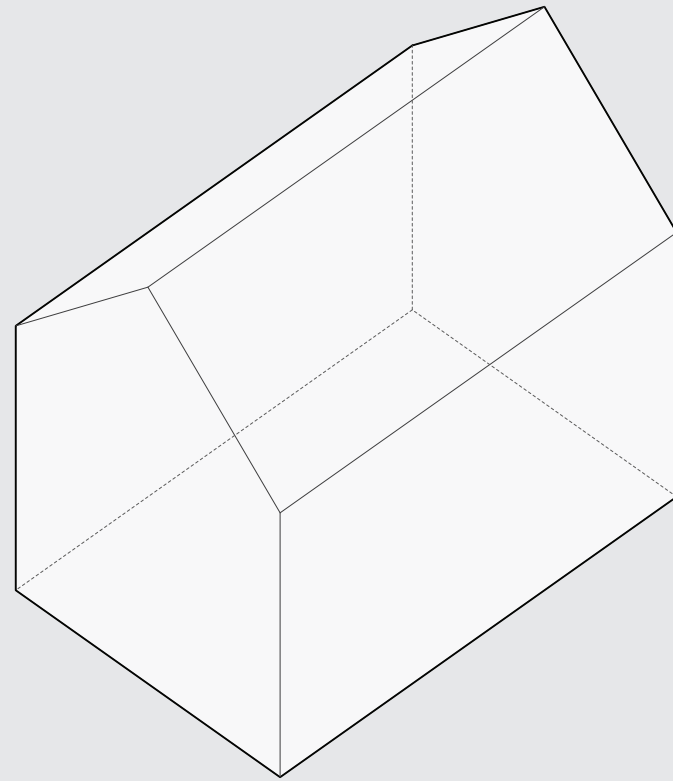

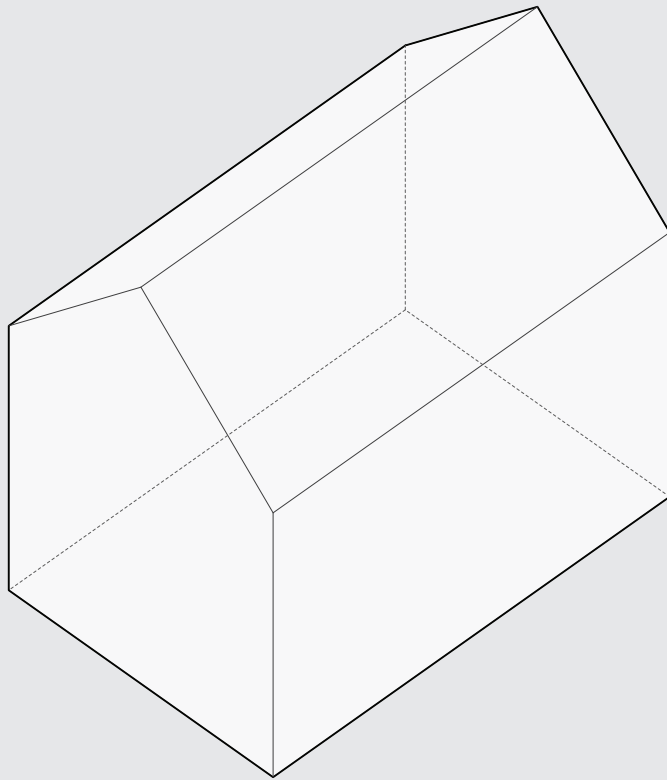

C // LONG LIFE SPAN

Another important advantage of composites are the extremely long life spans. I am proposing that my Case Study House will last over one hundreds years, with little or no maintenance.

One of plastics most controversial aspects is the life span. However, in many ways the long lifespan is also one of the best advantages of plastic. Plastics are famous for polluting our oceans and shores they are resistant to weather, chemicals, water, etc., and have a tendency to be indestructible and impossible to dispose of. However, this durability can also be part their advantage and fortunately, some plastics can be recycled.

When plastics were first introduced into mainstream American culture the world was in a very different place; oil was cheap and plastic was unlimited. The introduction of plastic during this environment lead to a mentality and culture that has been ingrained into us. Driven by the idea that plastic is cheap and disposable, it has become a representation of the excessive. Plastic has become a synonym of cheap and a description of poor quality. However, it is important that these misconceptions clouding the reputation of plastic are cleared, and its true value redefined.

BOEING 747 // PARTS : 6 MILLION // ASSEMBLY 4 MONTHS

BOEING 767 // PARTS : 31 MILLION // ASSEMBLY 3 WEEKS

1970

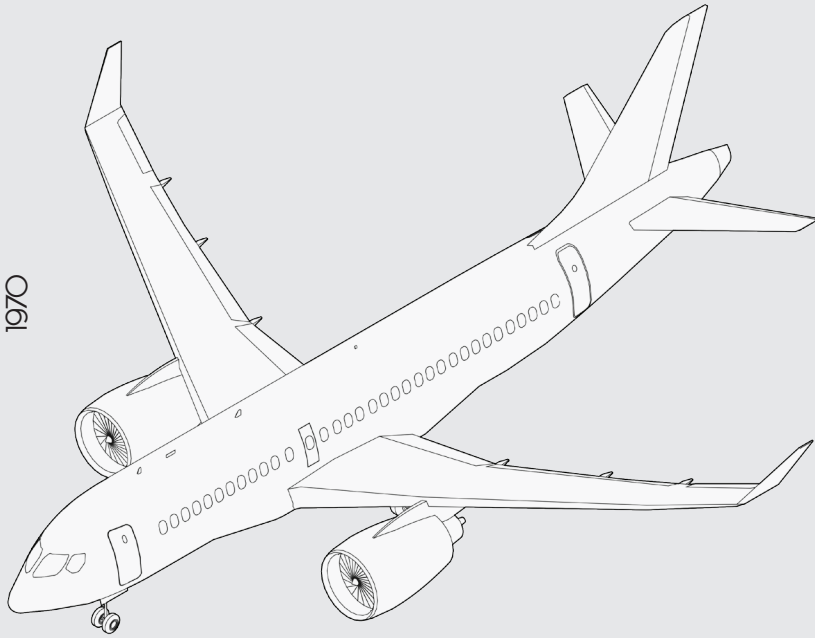

1979

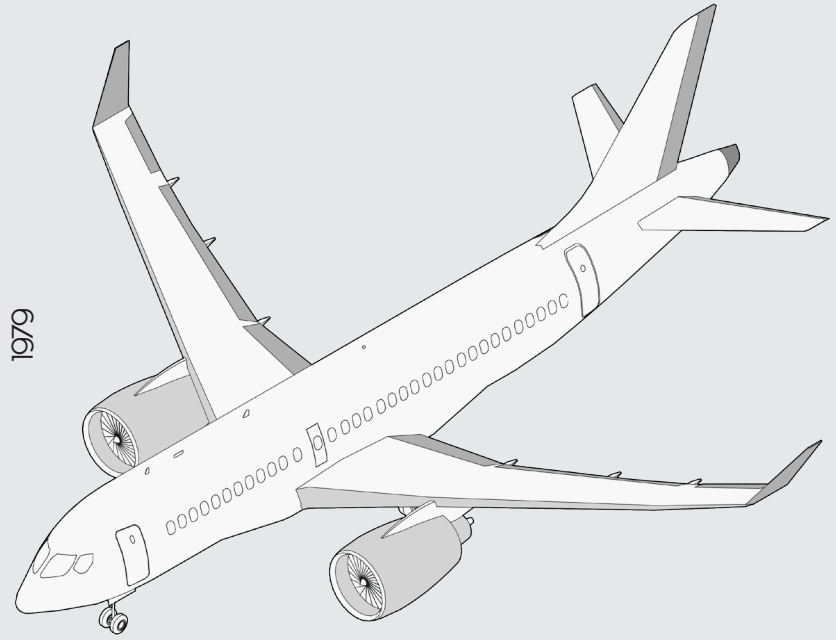

2012

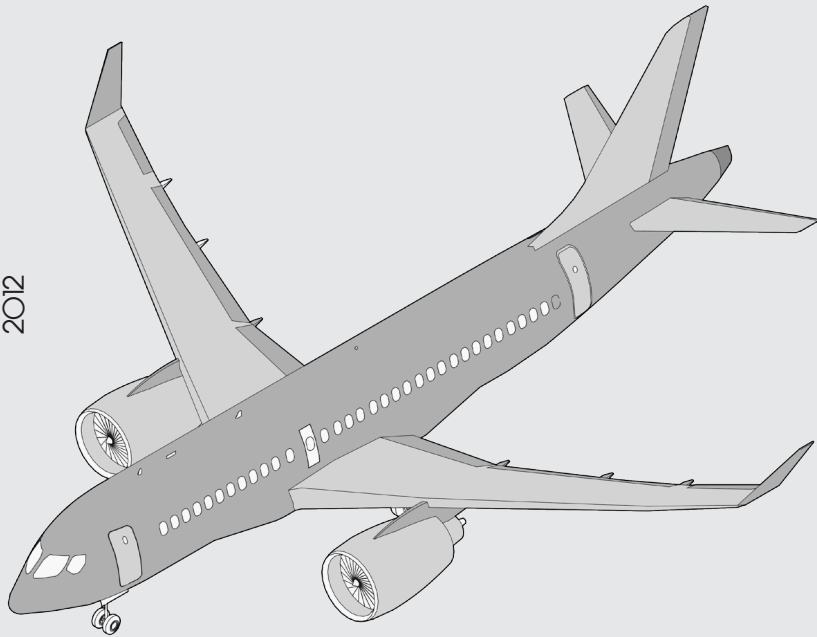

We consume plastic at incomprehensible levels, from our daily use of plastic bags and tupperware, to packaging and bottles. It is as though we do not realize that it is one of the longest lasting materials created. Other materials such as wood rot and even steel rusts.

The shift in many airlines companies to use composites and plastics results primarily from their long lifespan with very little maintenance. The costs saved from switching from aluminum to polymers would be immense.

D // INTELLIGENT PARTS

Because of composites' nature the panels are mold-ed, this allows for extremely complex geometries to be produced in a single panel. It also reduces the number of required parts, greatly simplifying and accelerating the assembly; assembly can be completed with a handful of individuals, rather than a large construction crew.

Traditionally structures made of wood or steel are broken down. They are then cut into individual parts and assembled, either by welding, gluing or with fasteners. Even in the construction of the simplest buildings, it could take thousands and thousands of parts, with some joints, re-quiring hundreds of individual components. When it comes to composites and plastic, extremely complex joints or assemblies can be made at one time. The advantage of a simplified assembly is that when using fewer, smarter parts an entire house can be made by simply plugging a handful of parts together.

2 STORY CMU HOUSE

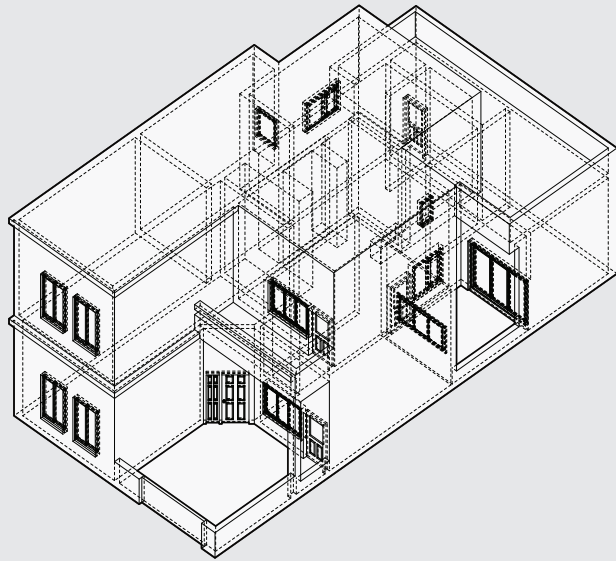

2 STORY WOOD STUD HOUSE

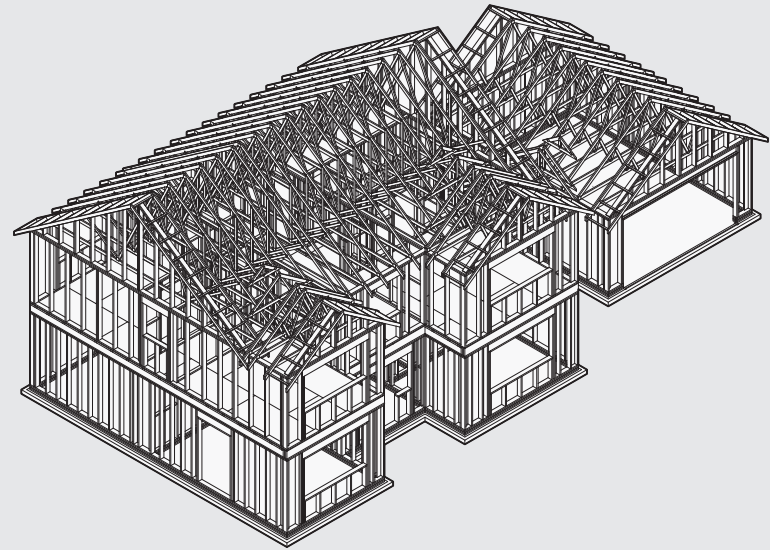

5 STORY COMPOSITE HOUSE

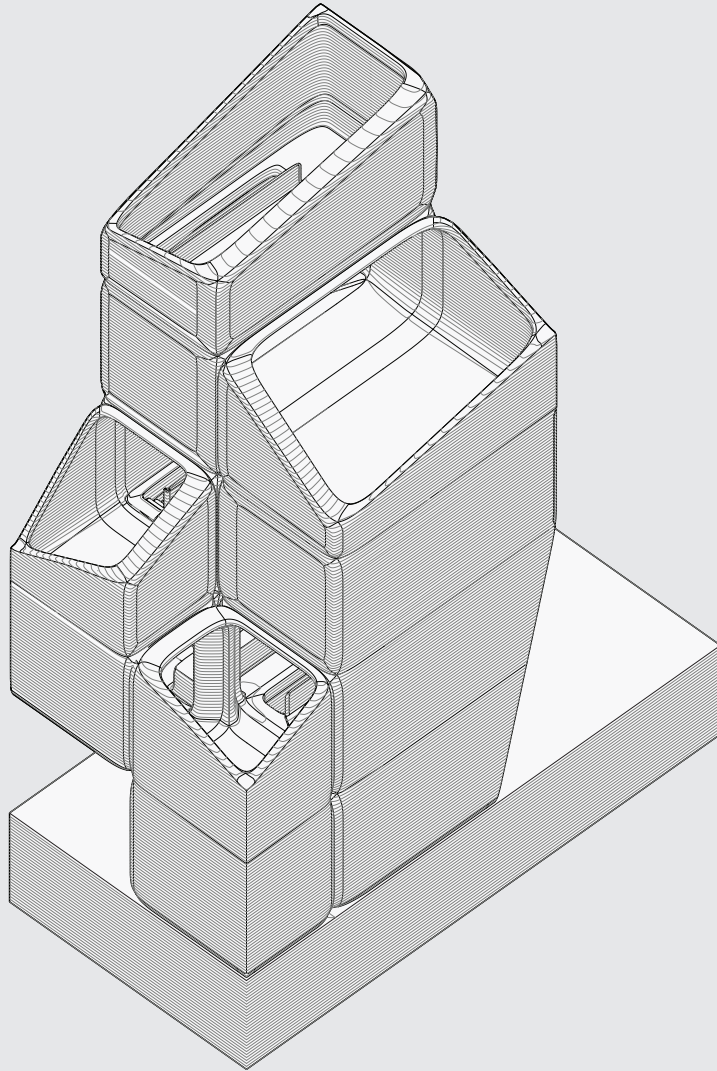

E // INCREASED CAPACITY

We have always been bound by the limits and capacity of our materials. Due to material limitations, traditional dwellings range from two to three stories in height. Whereas with composite materials the same limitations do not apply. Wood joists have a certain span in which they are efficient, and plywood has a certain distance upon which deflection is negligible, however with composites these spans are greatly expanded. Twelve inch wood joists and eight inch thick concrete slabs can be replaced by a four inch thick composite.

RESULT

The result of these various advantages is a case study house that will have a one hundred year life span. Using parts that will be delivered to the site at one time, the home can be assembled in one day, by four people, and with no large equipment. This will challenge traditional understandings of heights and spans, and where the interior and exterior skin align and diverge, in order to anticipate apertures, stress loads and program.

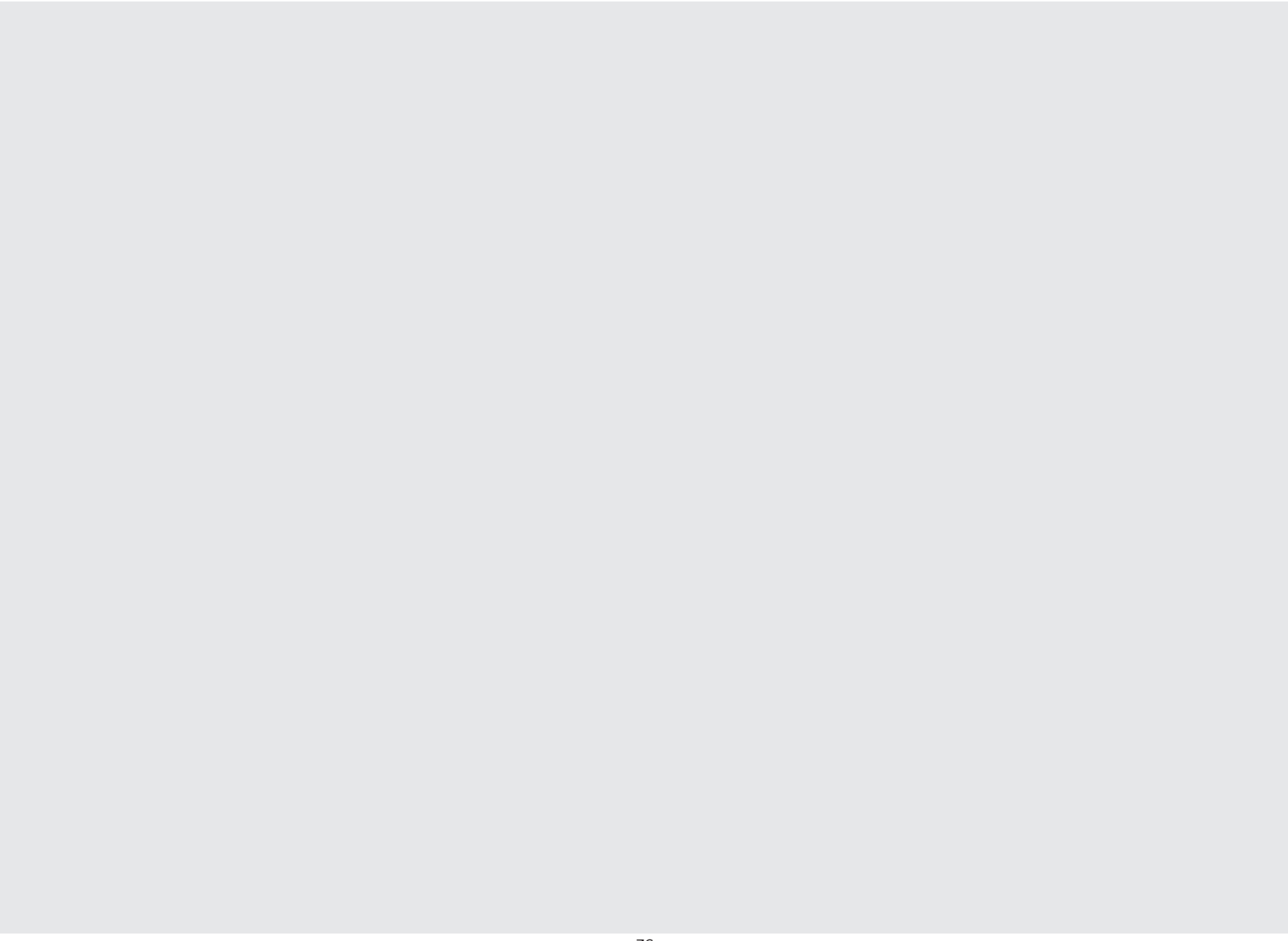

O1 // MATERIALS

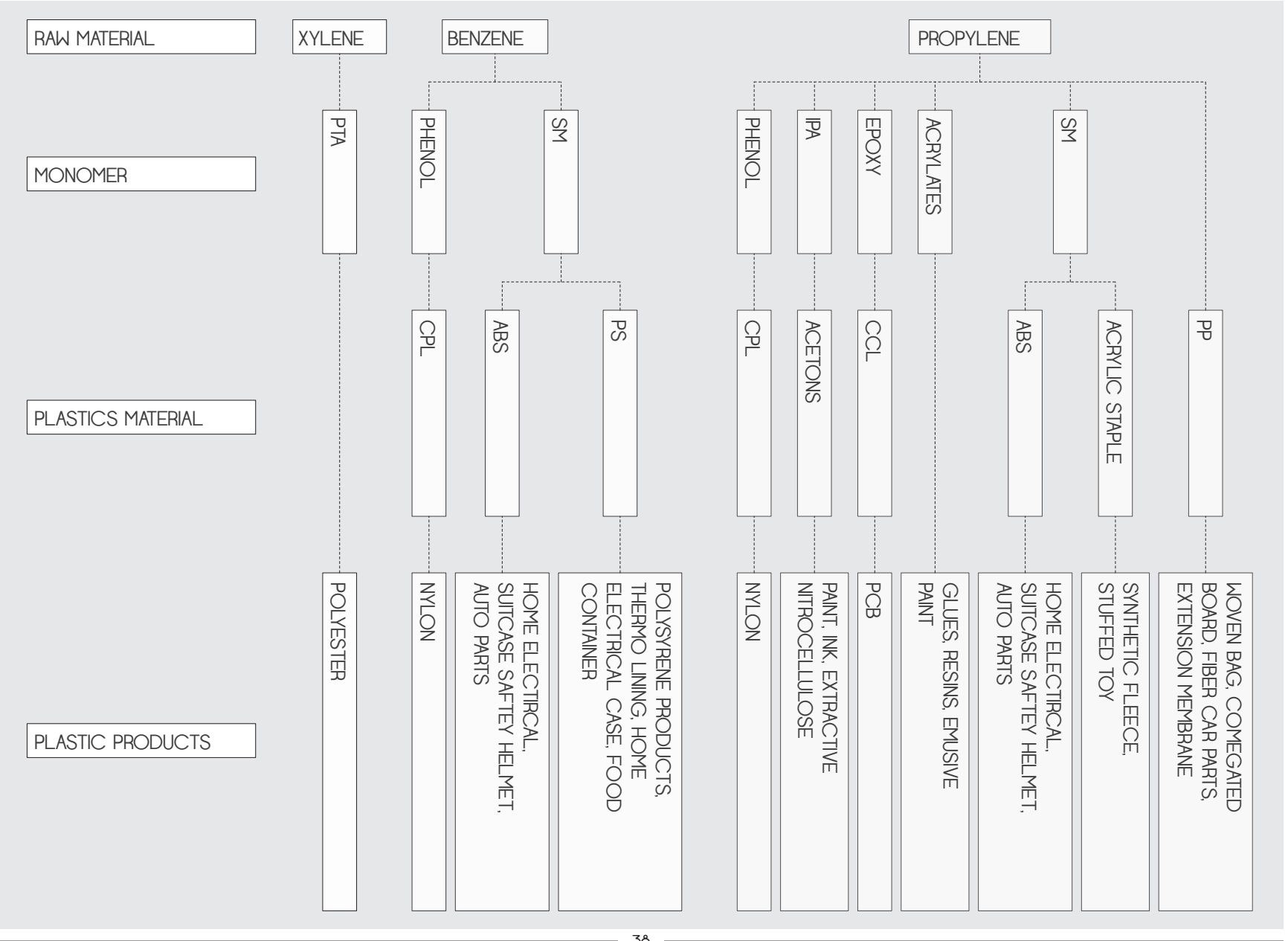

PETROLEUM MATERIALS

The Case Study House is 100% petroleum based. Various petroleum based products will be deployed depending on the structural and mechanical properties required for various components. The case study house will be comprised of a combination of common plastics, such as acrylic, polyethylene, PET and polypropylene, fiber reinforced plastics (FRPs), and finally composites.

Petrochemicals can be broken into two main classes olefins and aromatics. Olefins include ethylenes and propylenes, whereas aromatics include benzenes and xylenes. Ethylenes are best known for their use in making polyester and PVC (polyvinyl chloride); propylenes are known mostly for their use in acrylic polymers and epoxy resins. Benzenes are best known as polystyrene, polycarbonate, polyurethane and nylon and xylenes are best known for their use in PET or polyethylene terephthalate.

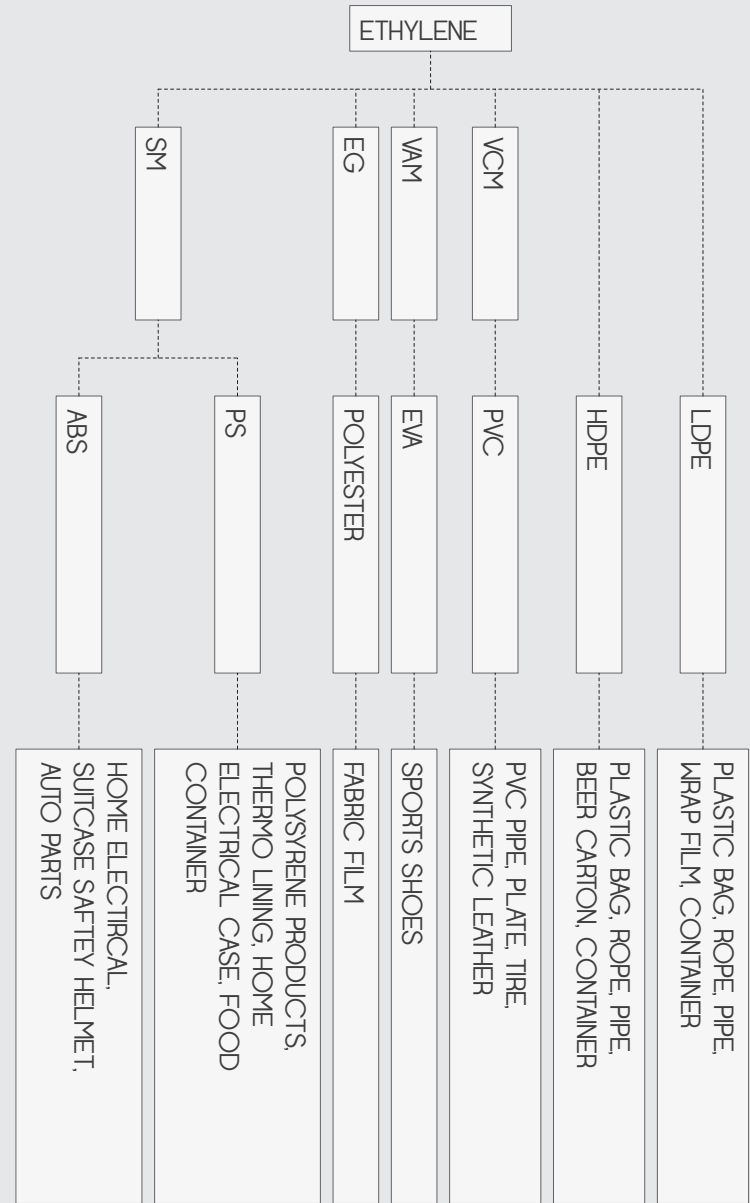

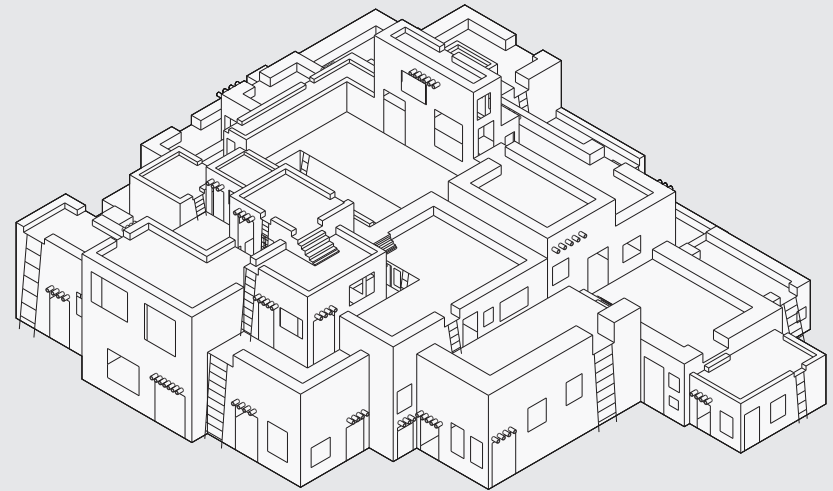
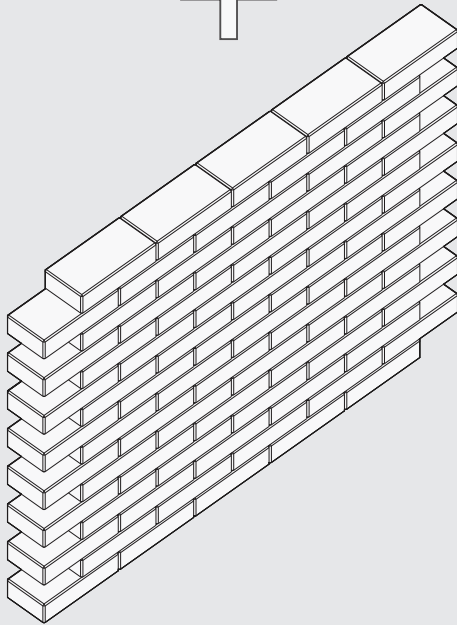
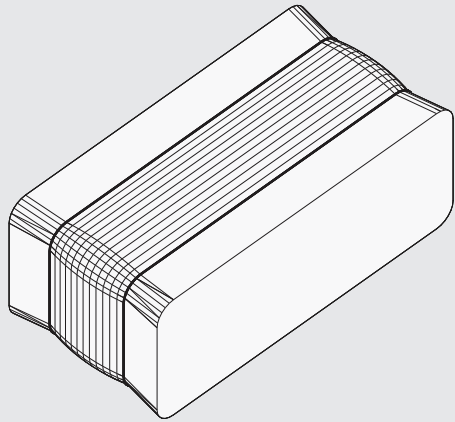

COMPOSITES

Composites are built upon the premise that distinctive material categories can be combined, to form a greater material, than the sum of their individual parts. In other words, by combining the strengths of various material categories, an ideal, superior material can be created. The first composite ever produced was adobe brick, it combined straw, which is strong in tension as a fiber, with mud, which is strong in compression as a matrix.

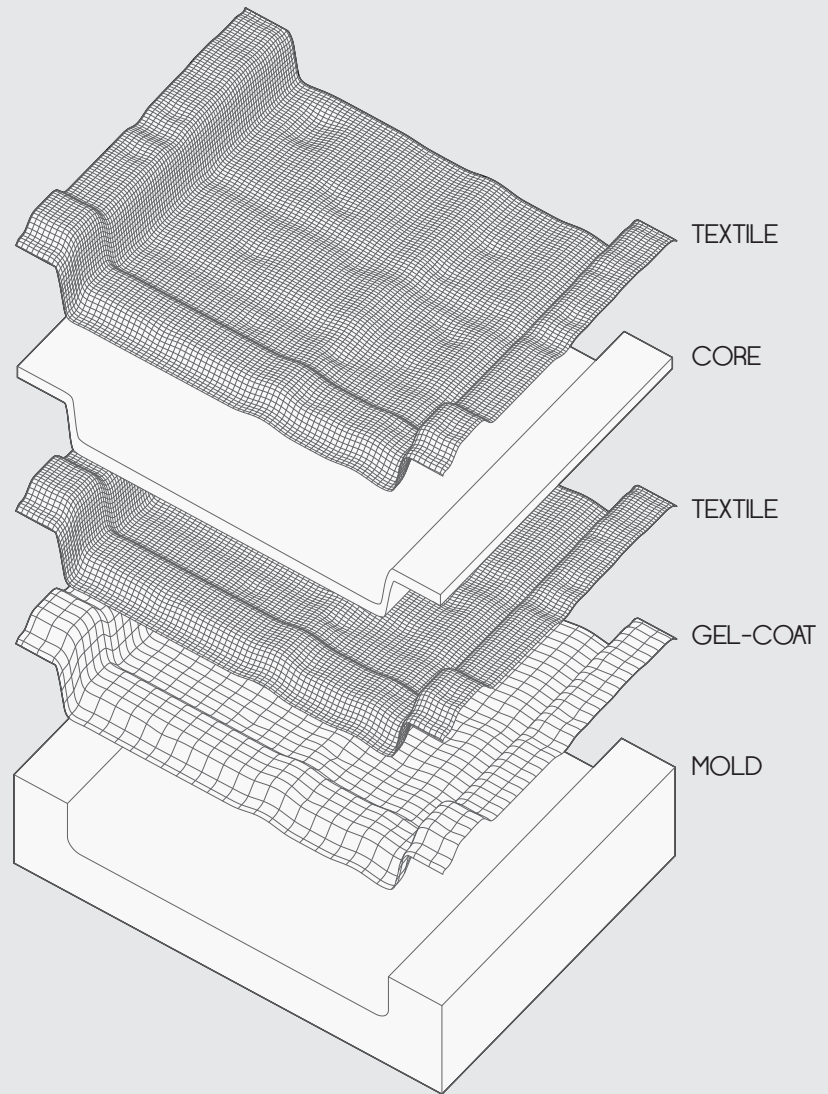

MONSANTO HOUSE : FRONT ELEVATION

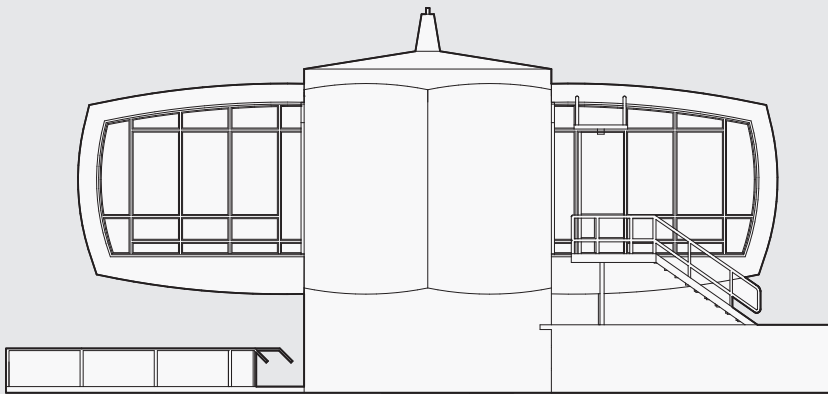

MONSANTO HOUSE : PLAN

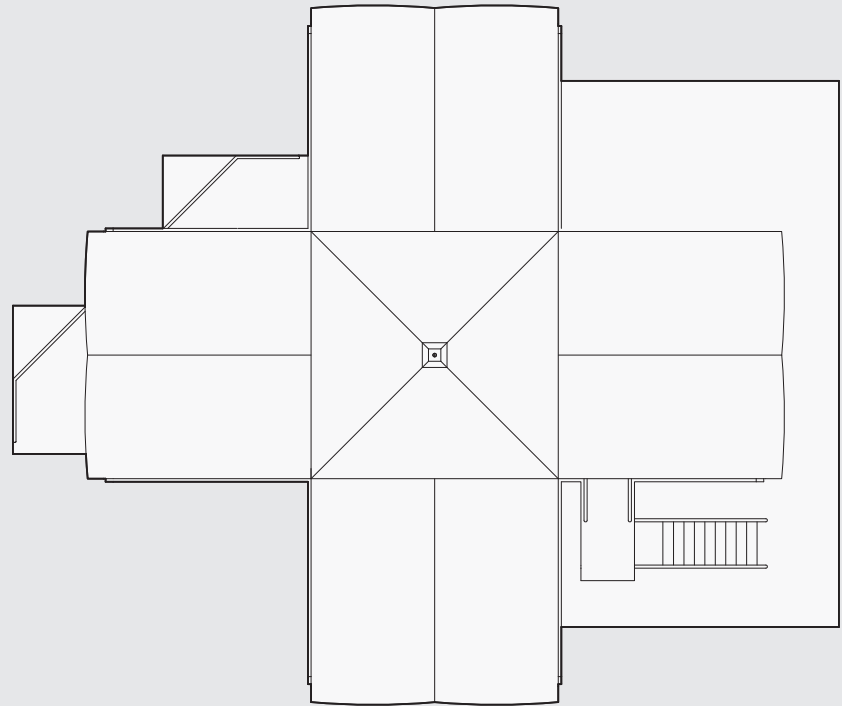

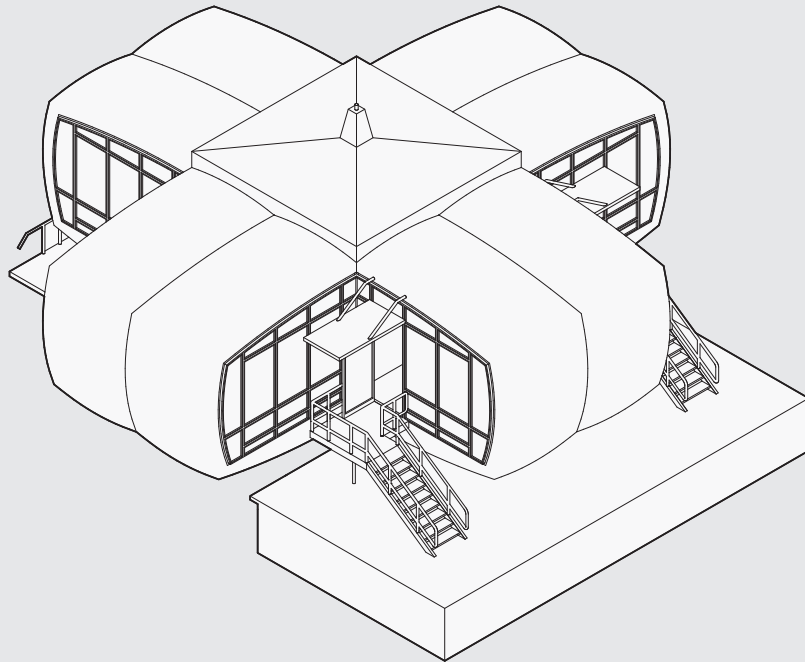

MONSANTO HOUSE

The Monsanto House of the Future was the first of very few precedents of a high performance, composite structure; it was designed by Marvin Goody & Richard Hamilton, and sponsored by the Monsanto petrochemical company. The Monsanto House was built in 1958 from fiberglass composites, and challenged the accepted notions of building materials and construction.

When the Monsanto House was scheduled for demolition in 1967, the process proved to be immensely difficult and took over two weeks. The wrecking ball bounced off of the exterior composite shell, unable to demolish the home. In order to demolish the house, it was deconstructed, and cut into many pieces to be removed.

The form of the house was based on a requirement that all the composites sections could be produced using the same mold. This resulted in the biaxial symmetry that led to the failure of the Monsanto House. Due to the one-off nature of the house, and the manually intensive and expensive construction, it was not a viable housing concept at the time. However, nearly sixty years later with digital manufacturing, we now possess the technology to make the development of the Monsanto House feasible.

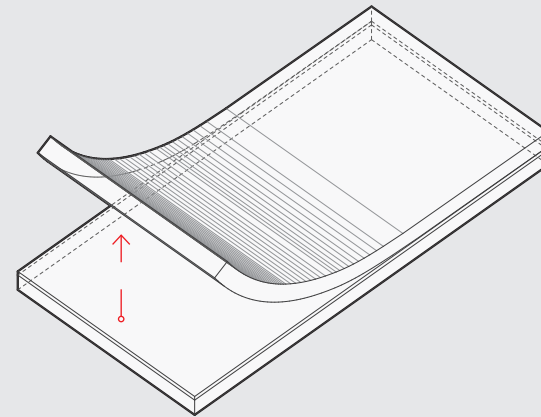
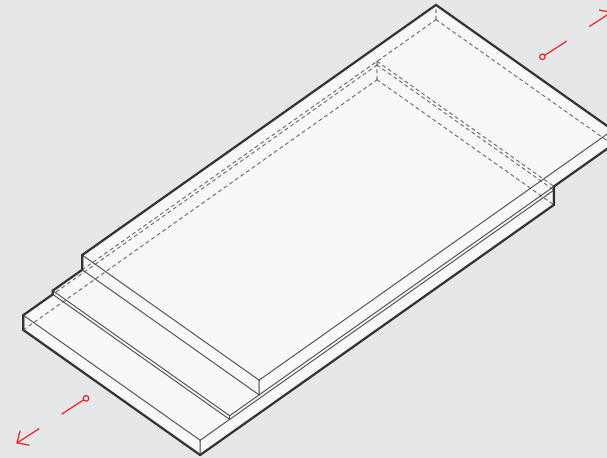
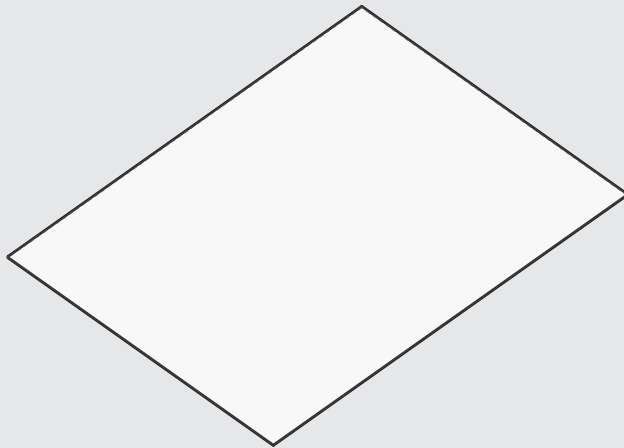
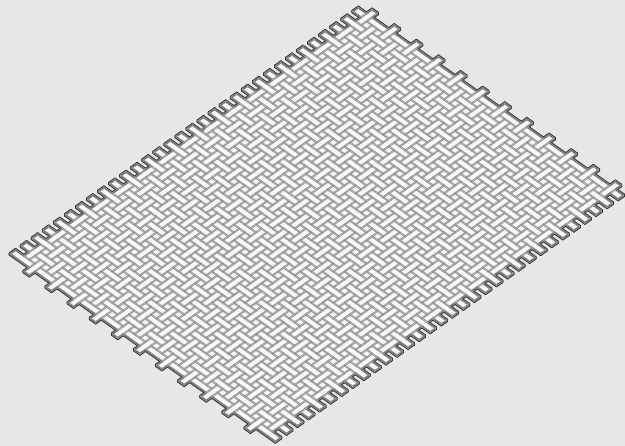

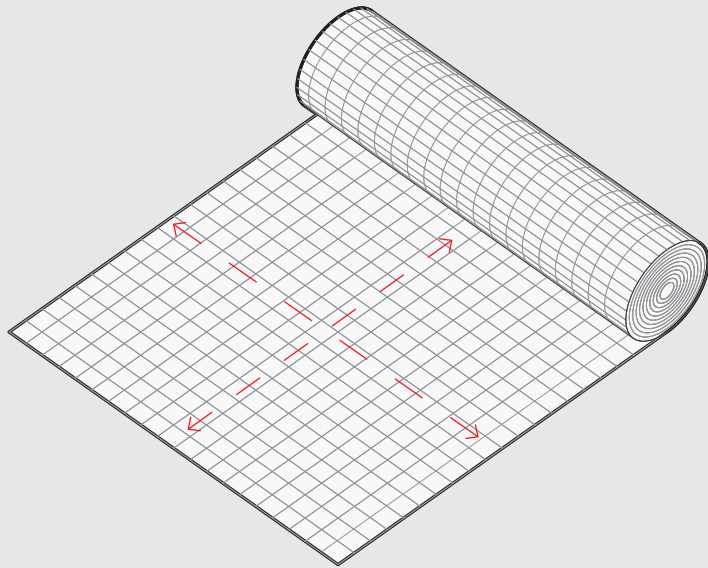

COMPOSITE CONSTRAINTS

In order to make the shift from composite rhetoric to a physical manifestation, I have outlined some of the most important design guidelines when working with composite materials. These guidelines include ideas of delamination in response to shear, compressive and tensile forces, draft angles proportional to part depth, fiber orientation in lamination, and mold design such as undercuts, sharp corners and single part molds versus multi-part molds.

UNDERCUT MOLD

2 PART MOLD

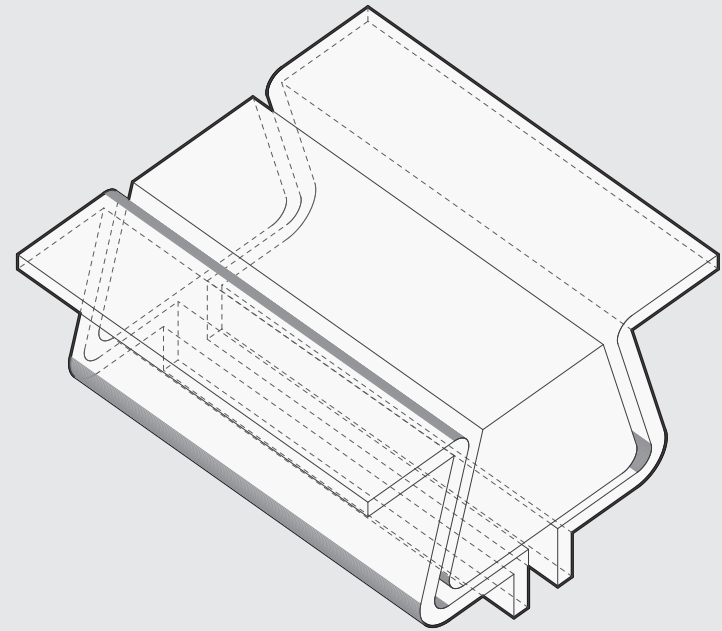
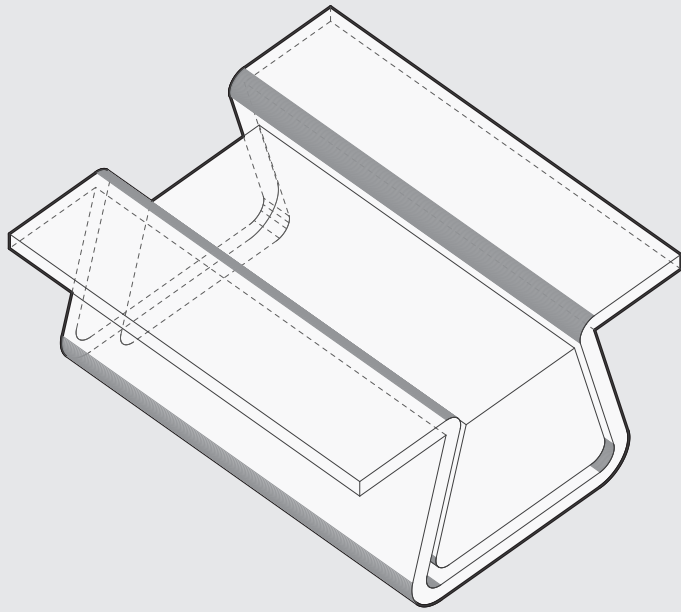

90 DEGREE MOLD

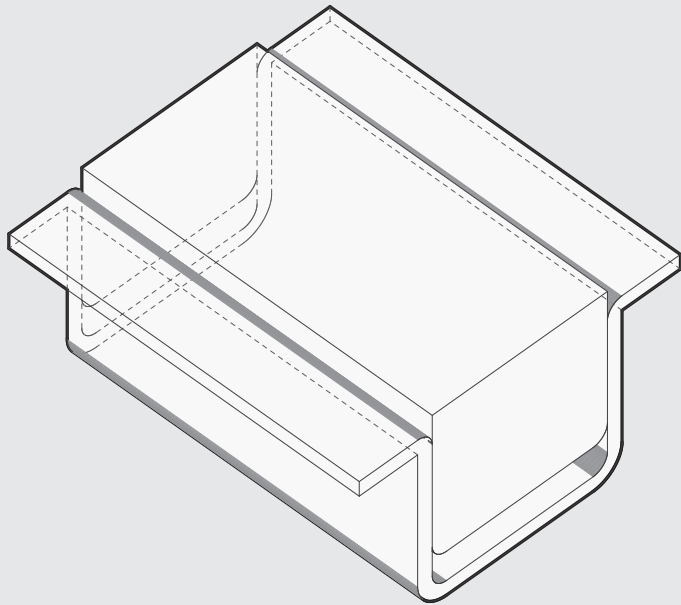

10 DEGREE MOLD

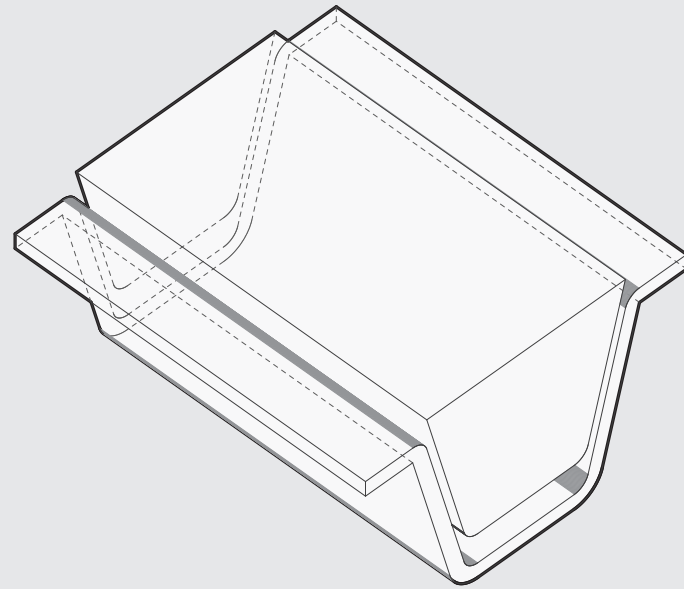

BAD MOLD

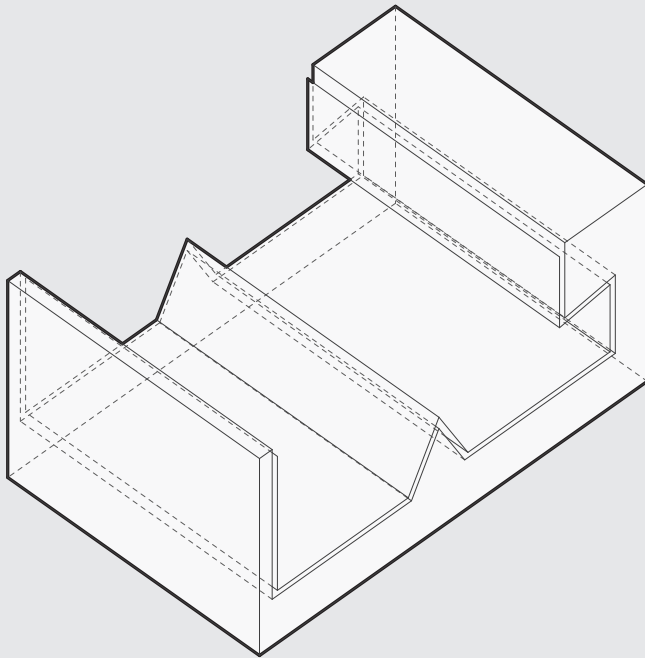

GOOD MOLD

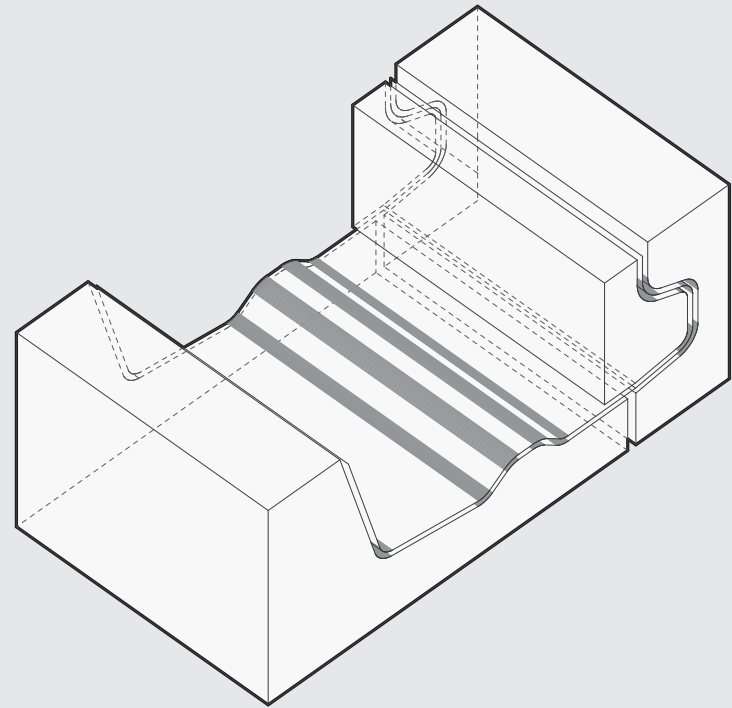

DEEP PART 15 DEGREE DRAFT ANGLE

SHALLOW PART 5 DEGREE DRAFT ANGLE

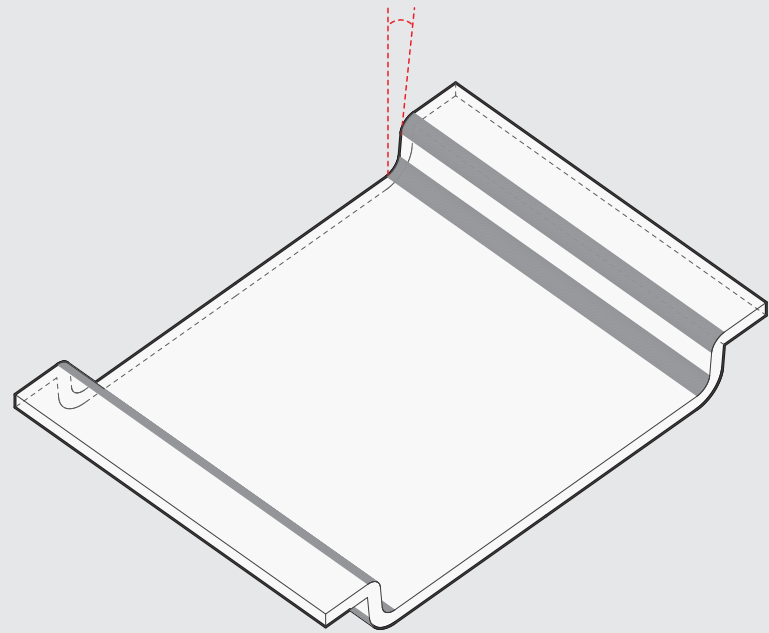
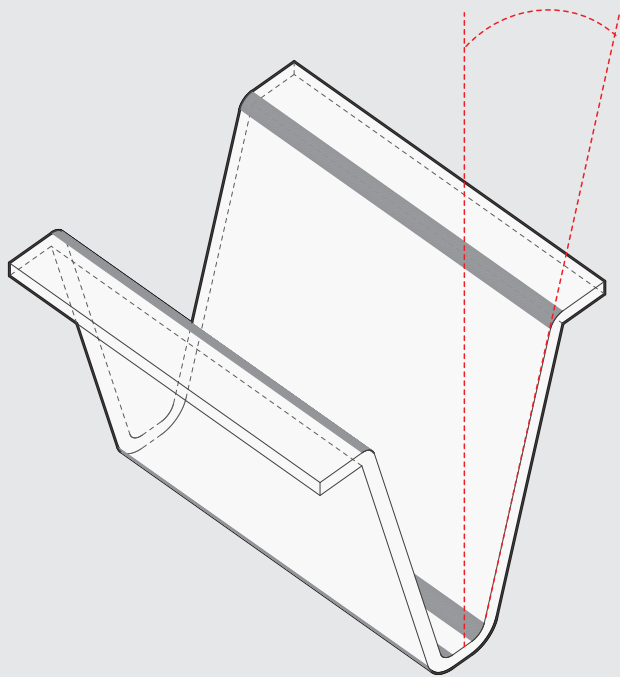

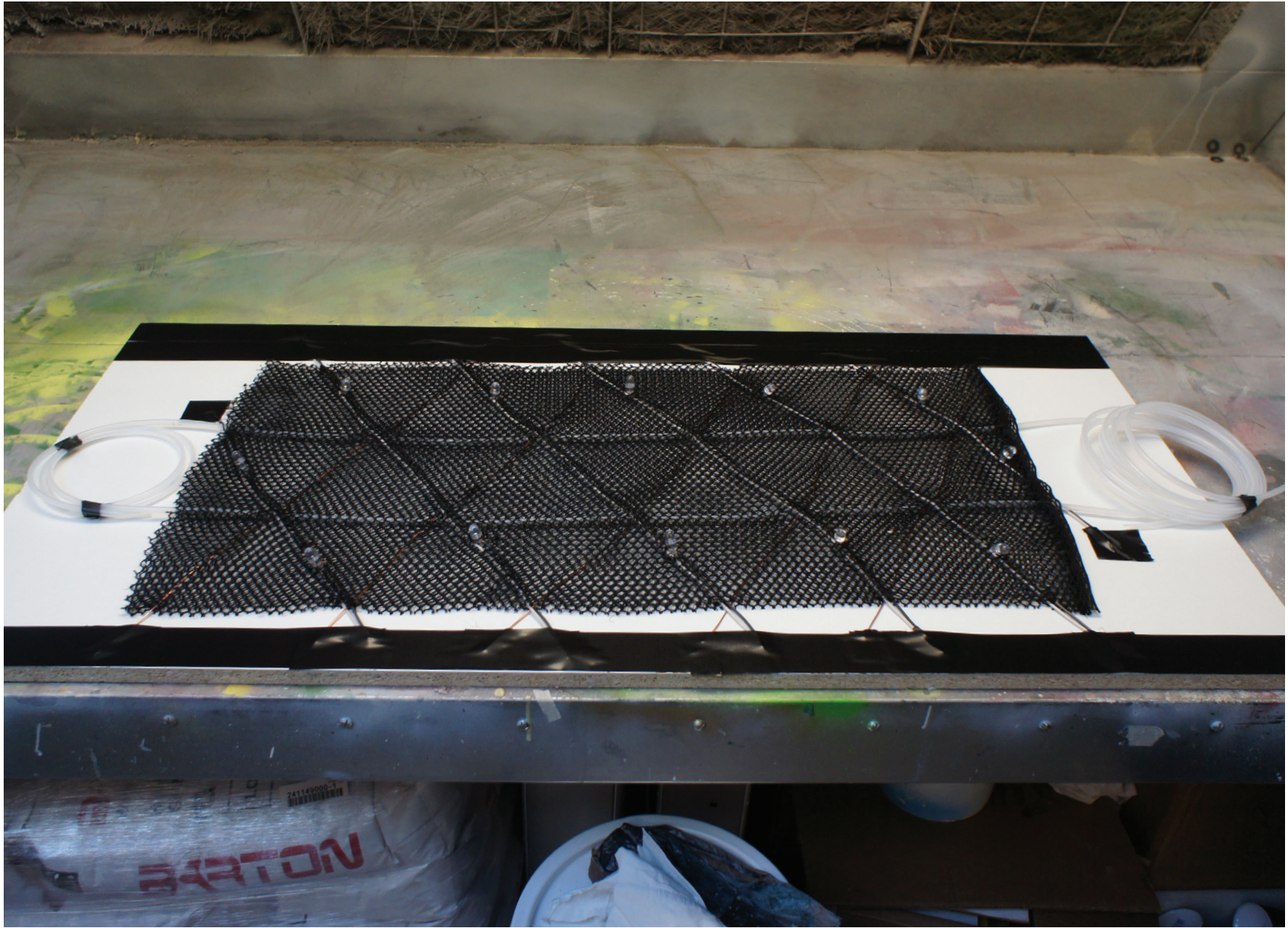

MATERIAL TESTING

In an attempt to truly understand the limitations of the material as well as the potentials, I began to work with them. Through prototypes, installations, furniture, and full scale models, the concepts and understanding that come from working with the materials could be applied and deployed across various scales.

My introduction to composite materials came through an elaborate series of mini tests. I began by testing various fibers and matrices. What became most clear through these tests was that the criteria by which the success or progress of a new material is judged, is very different with architecture than other fields. This is especially important when these materials and technologies are adopted from another field. In the adaptation of composites to architecture, we must also develop our own criteria for judging the success of integration, rather than copying the same criteria used in other fields. For example, in the field of high end sailboats, where composites have been used for many years, companies pay millions of dollars in order to save hundreds of pounds and achieve extreme light-weightedness. In architecture, we have the same chance to negotiate a wide variety of trade offs in order to efficiently and economically, incorporate these new materials within our own field.

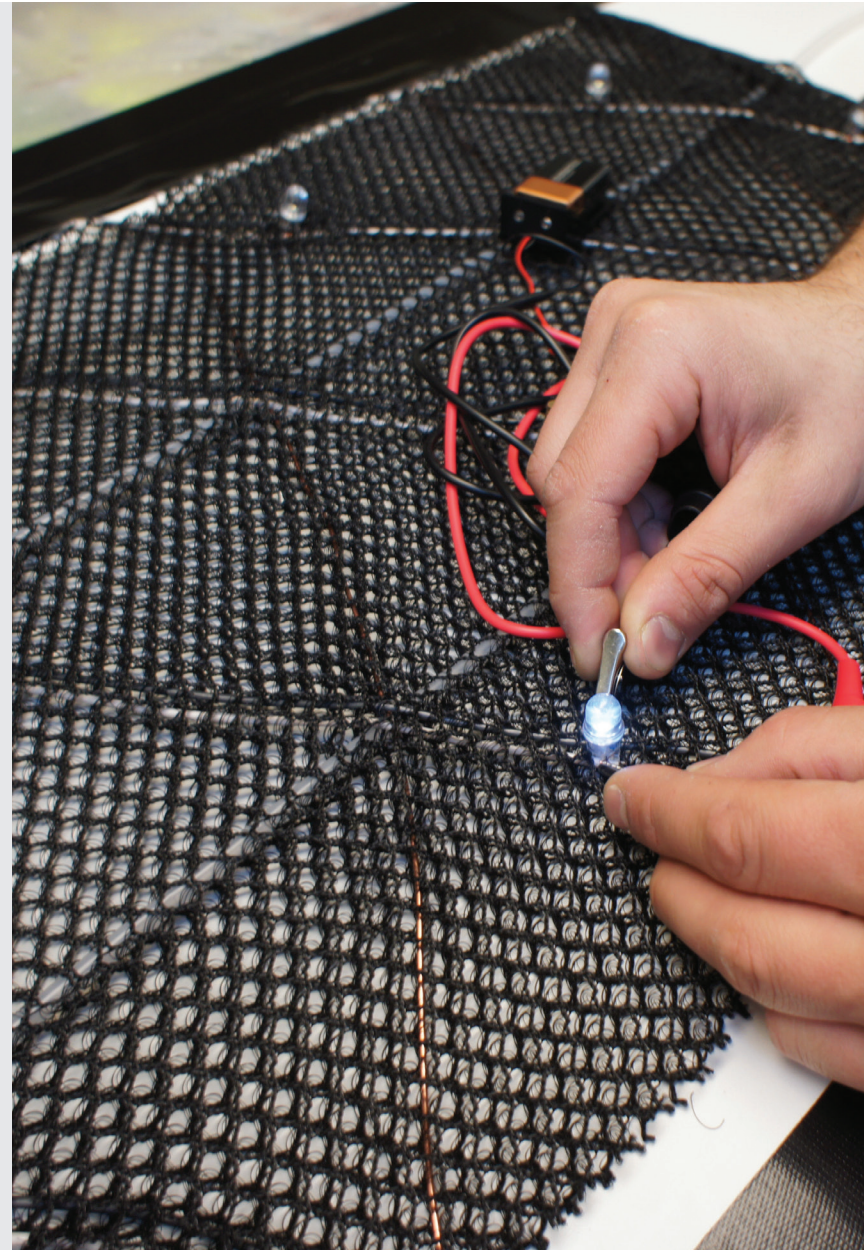



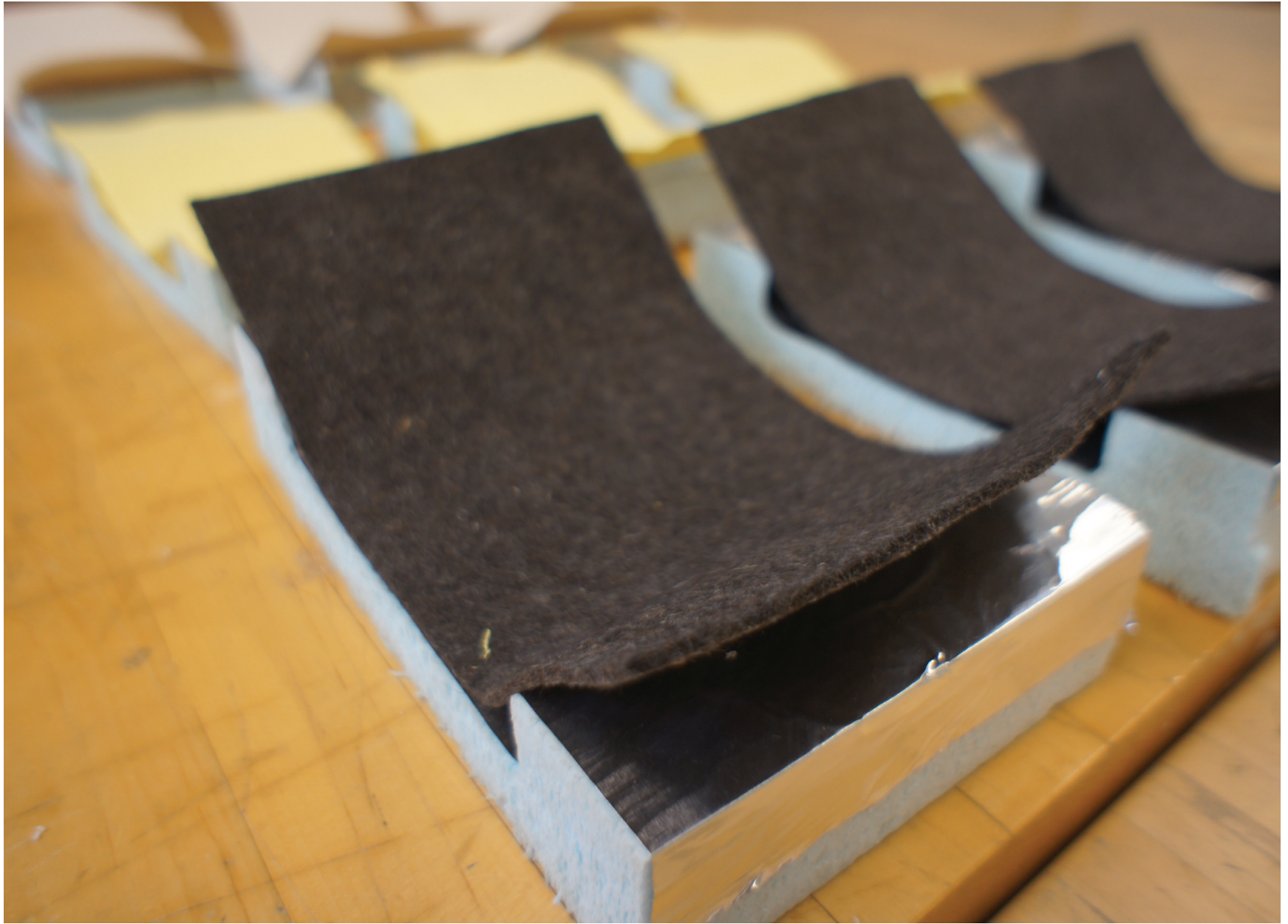



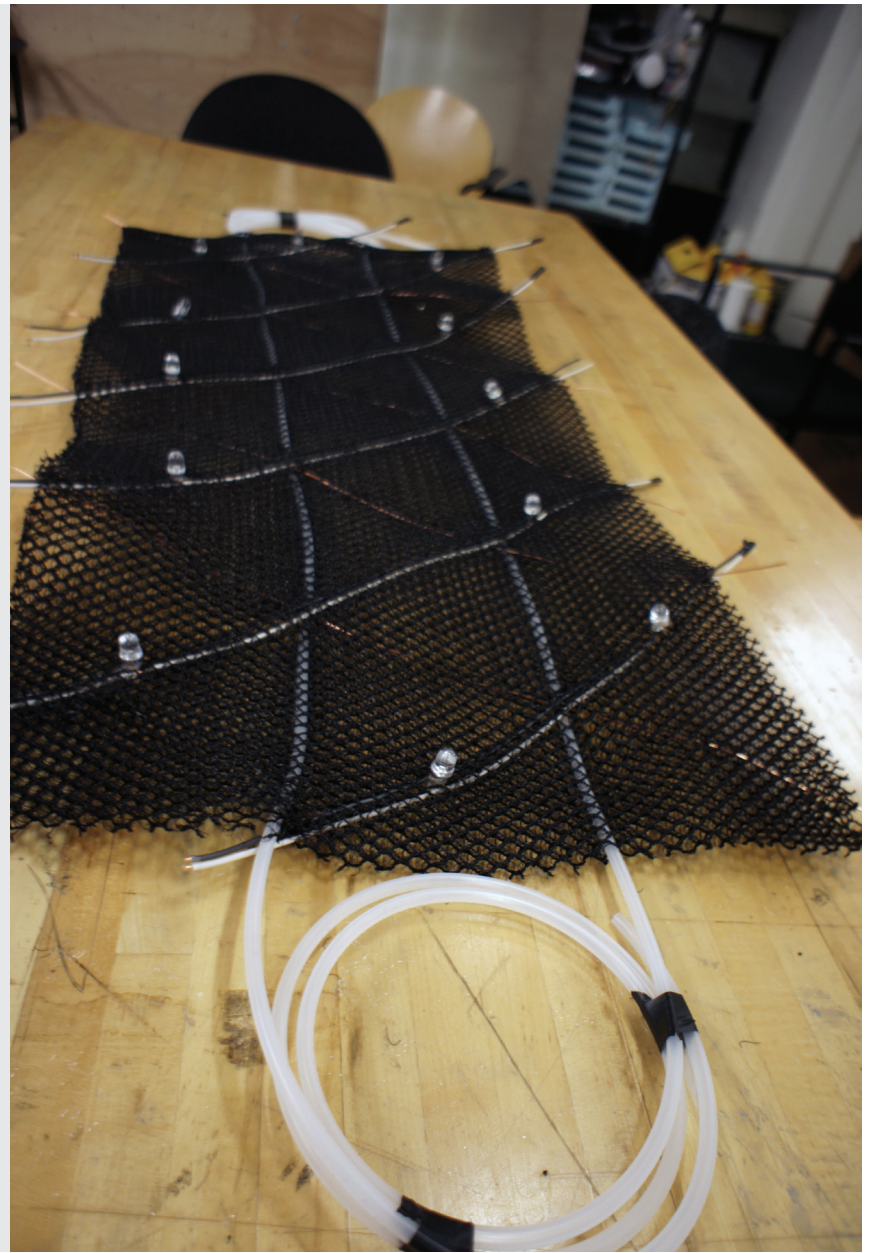
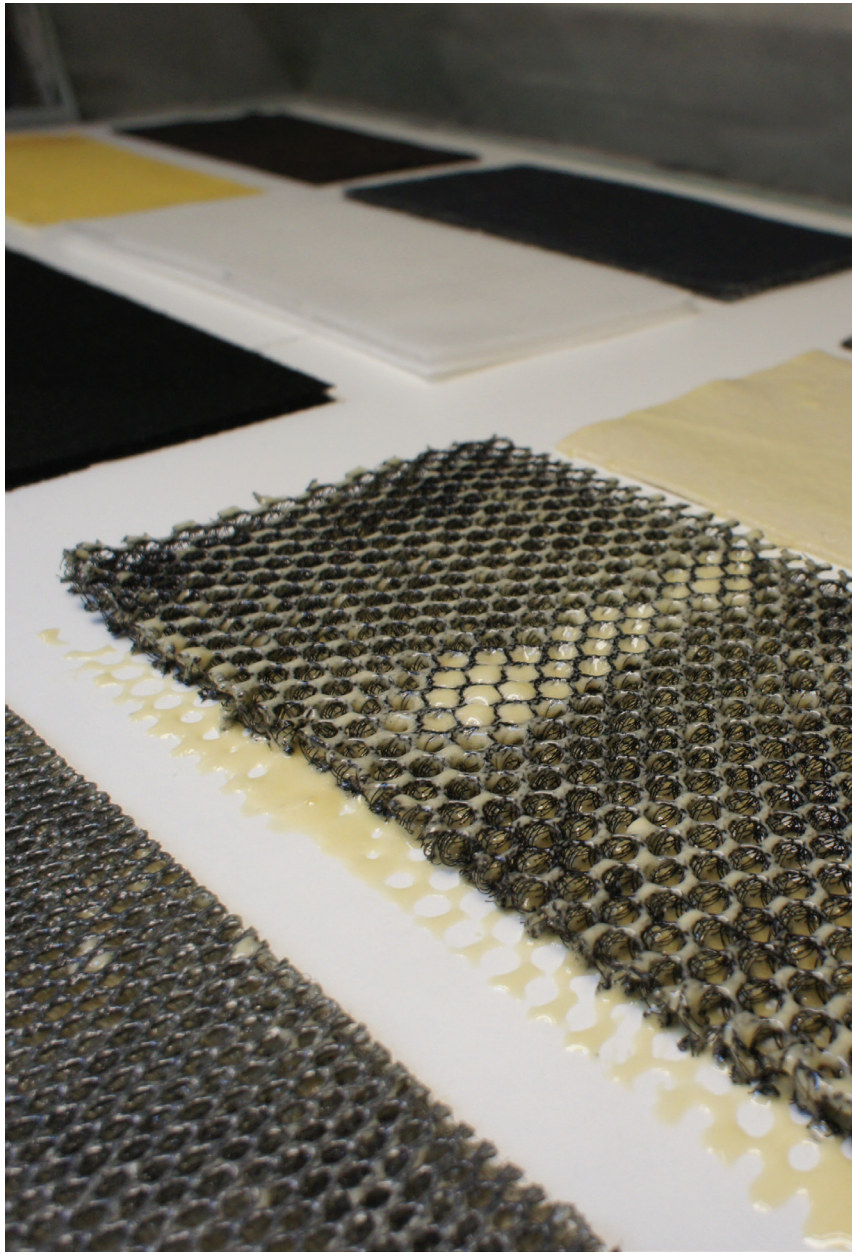

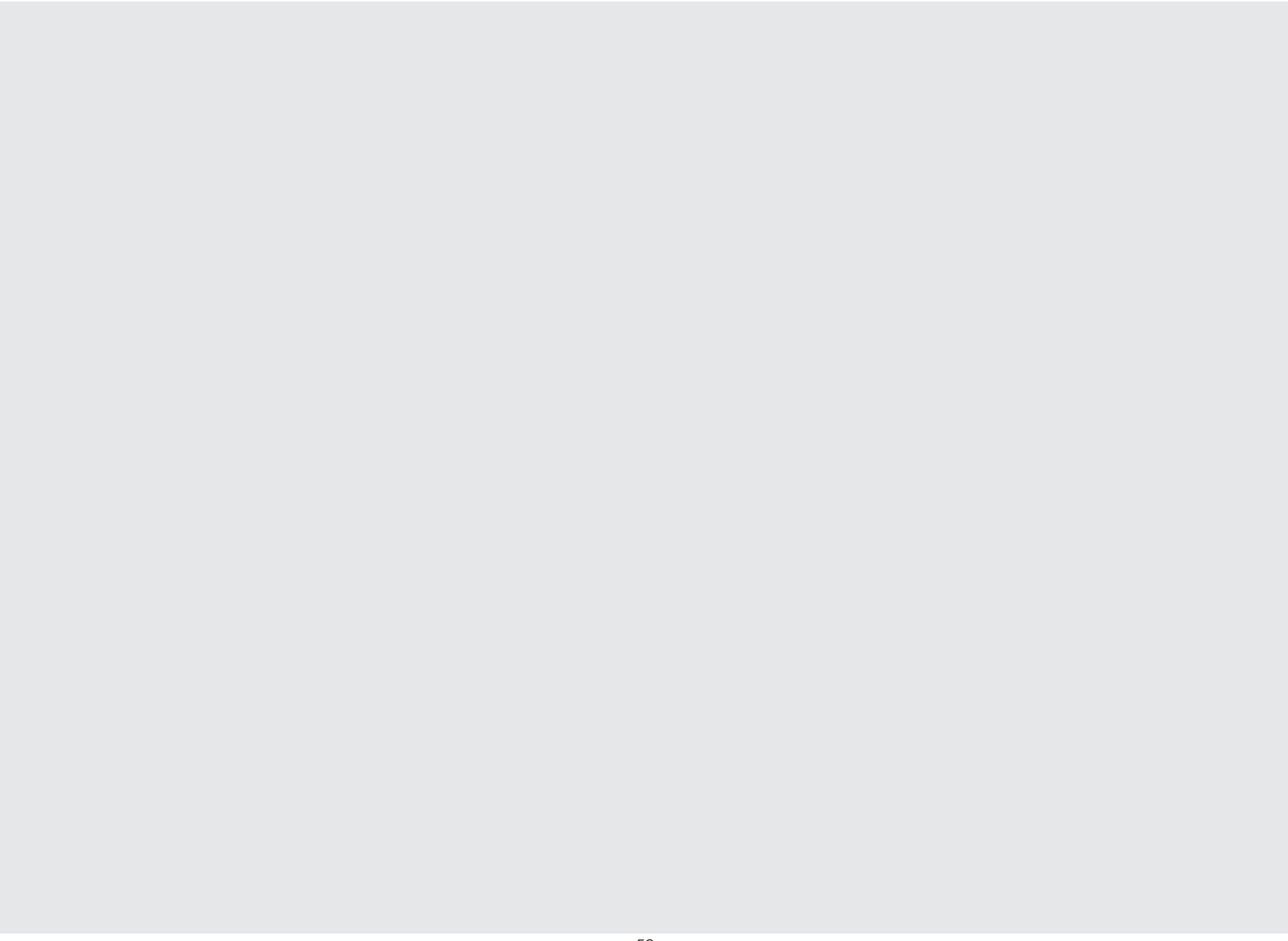

O2 // CONSTRUCTION

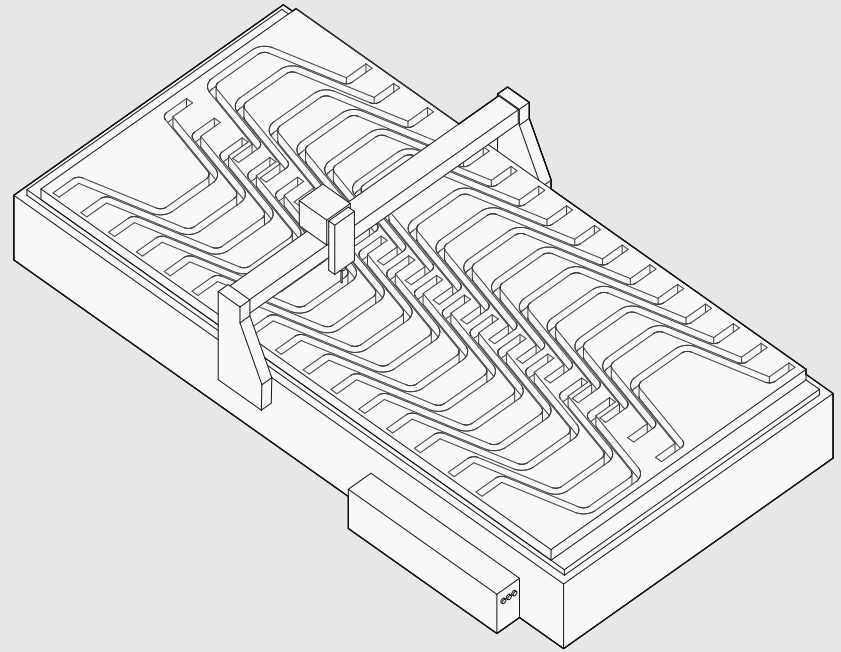
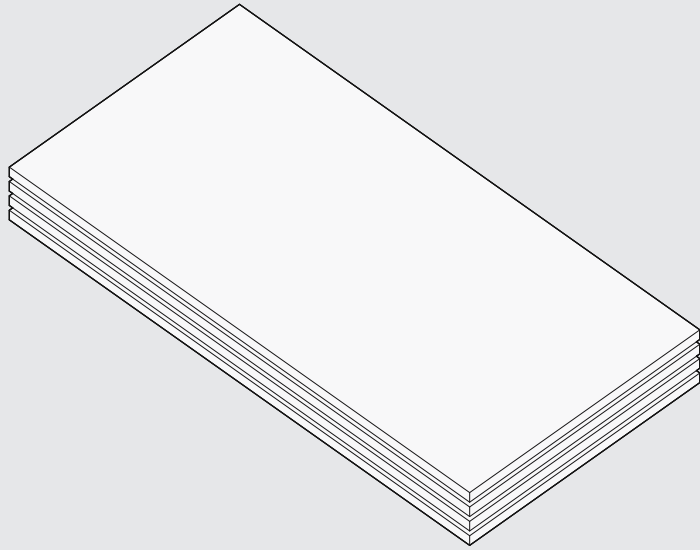

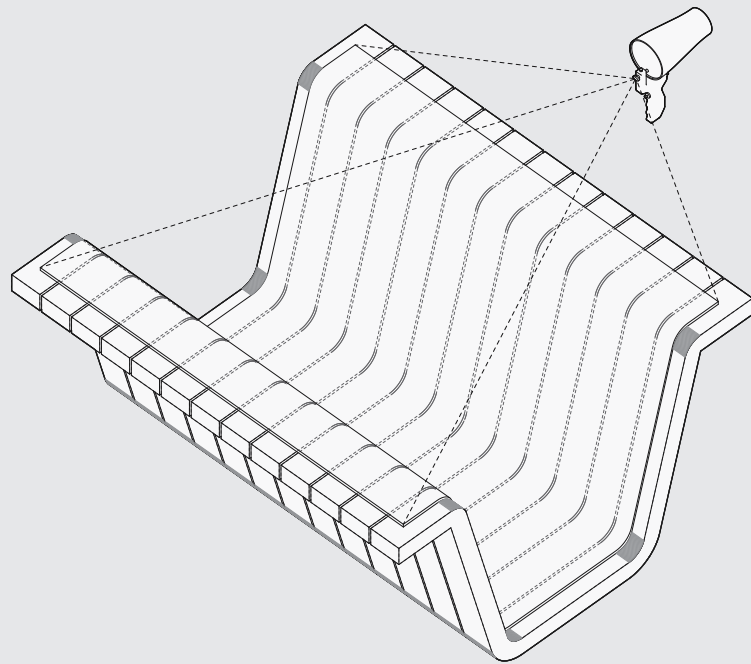

COMPOSITE MANUFACTURING

A typical composite part begins with the production of a mold. The geometry of the part is usually CNC milled out of a large sheet of foam. The many foam parts are then assembled and coated with a gel that seals the foam and provides a high surface quality for the part. The completed mold typically is used in one of four main processes: hand or wet layup, vacuum bagging wet layup, vacuum bagging resin transfer molding, or wet layup compression molding. In order to further understand how these processes work, I reproduced these traditional methods of production.

HAND WET LAYUP

VACUUM BAGGING WET LAY UP

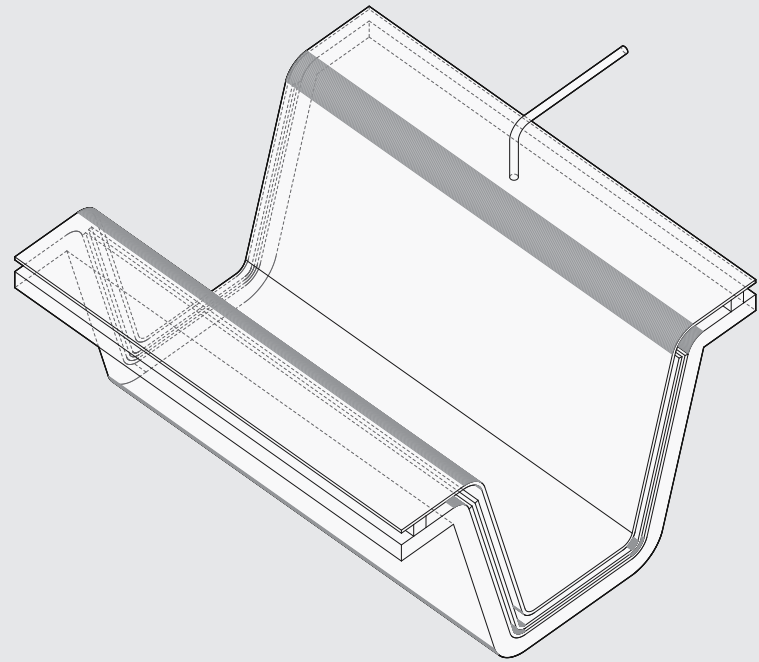
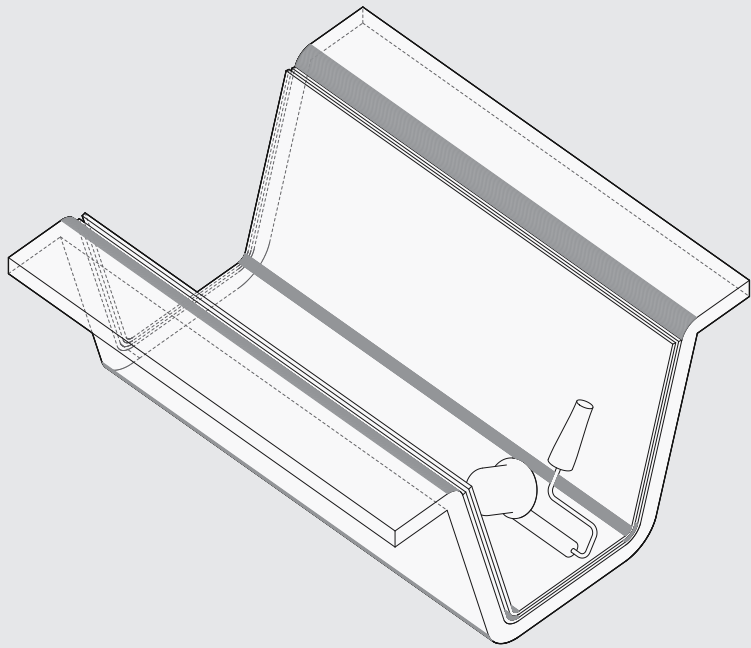

VACUUM BAG RESIN TRANSFER MOLDING

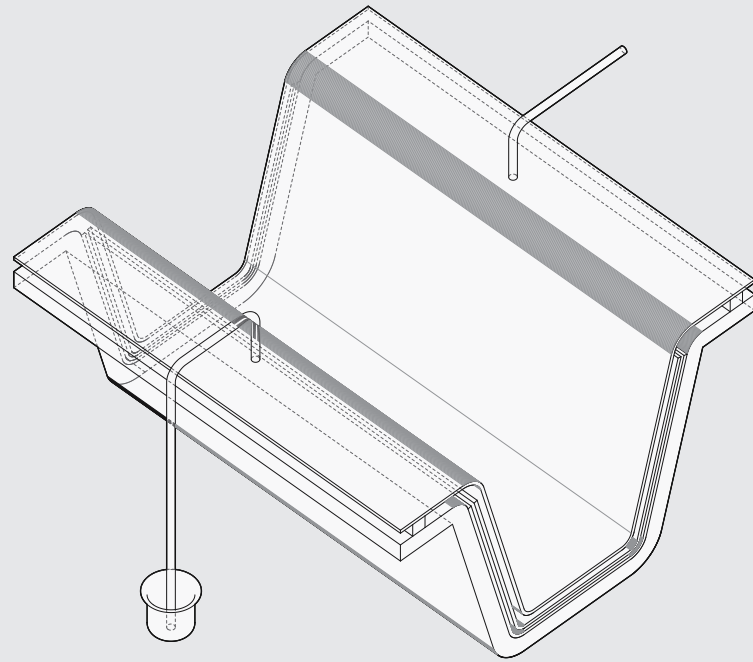

WET LAY UP COMPRESSION MOLDING

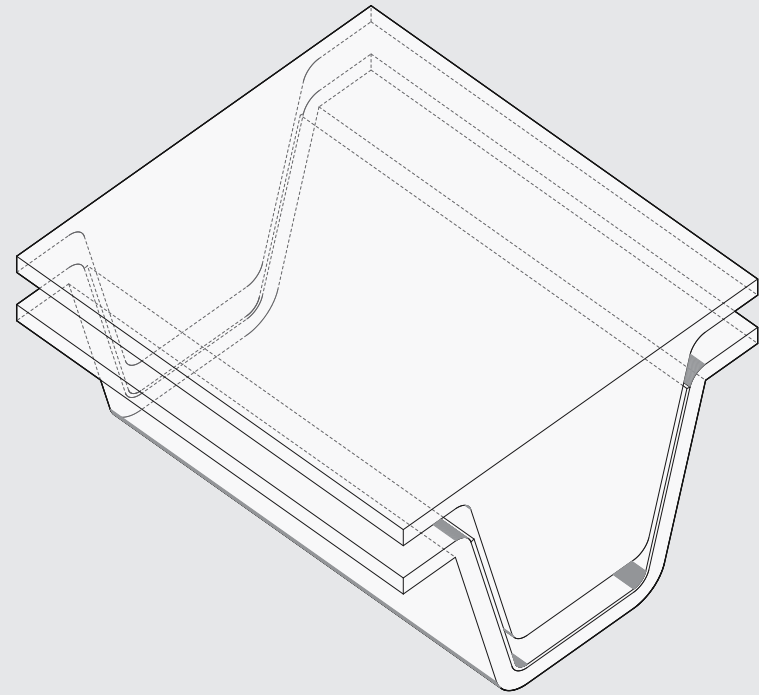

00 // BLEEDER

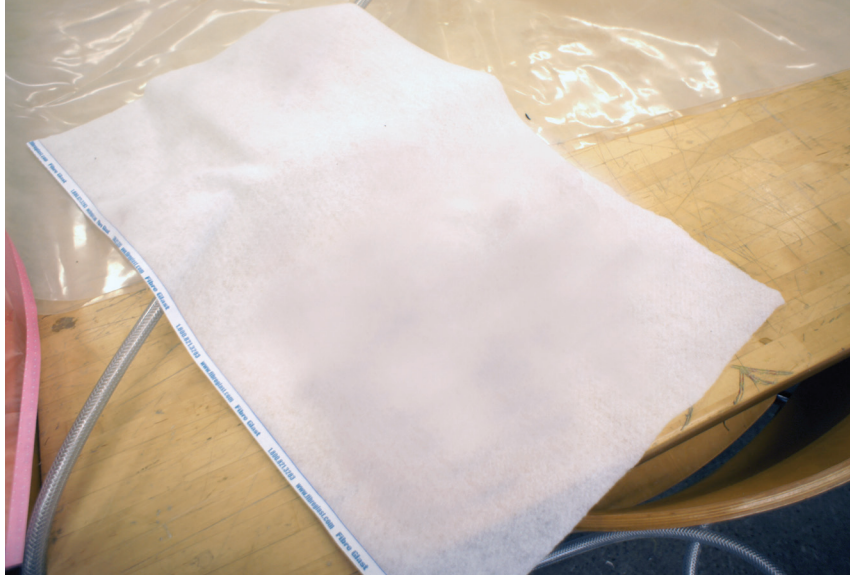

01 // ALUMINUM COATED MOLD

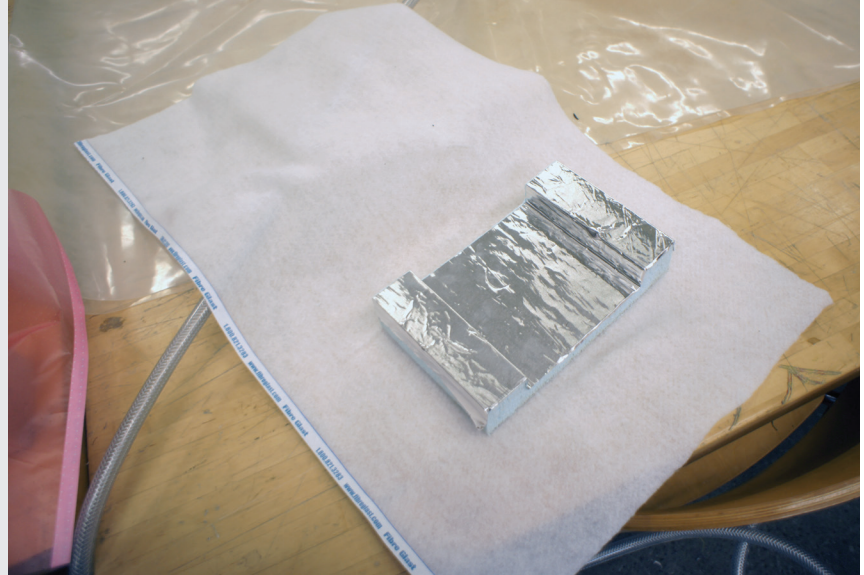

03 // RELEASE FILM



04 // BREATHER

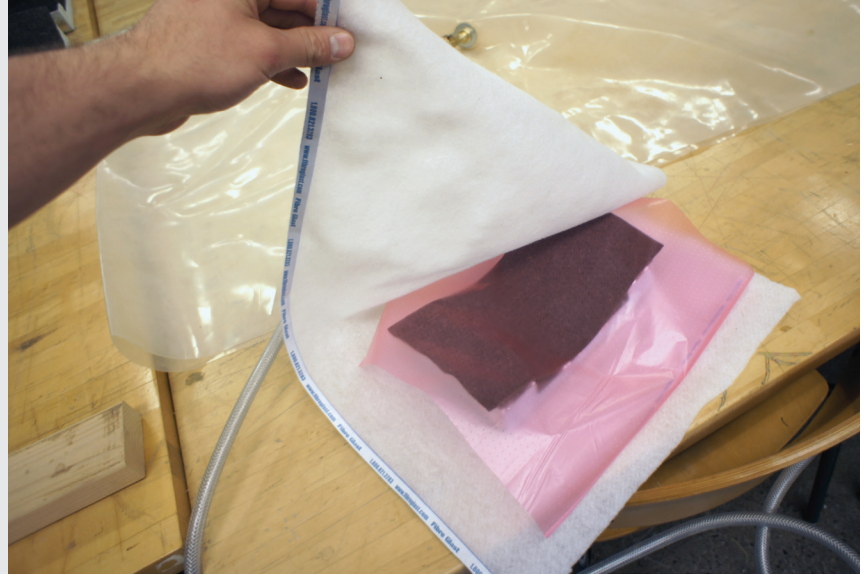

O2 // TEXTILE

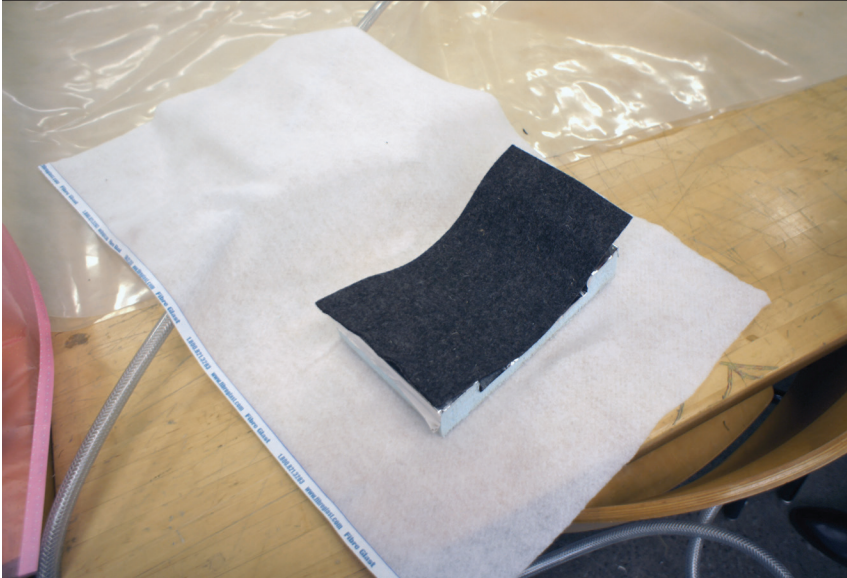

VACUUM BAGGING

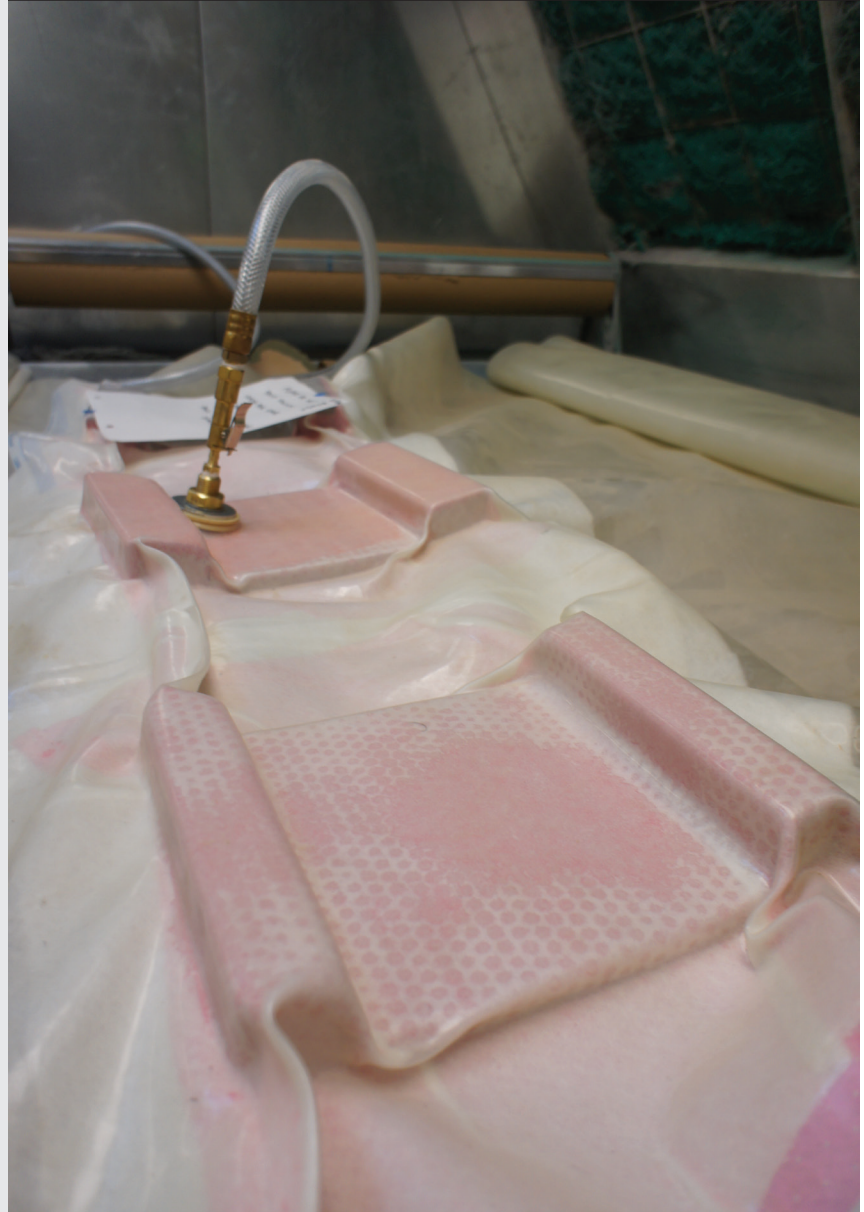

O5 // FINAL ASSEMBLY



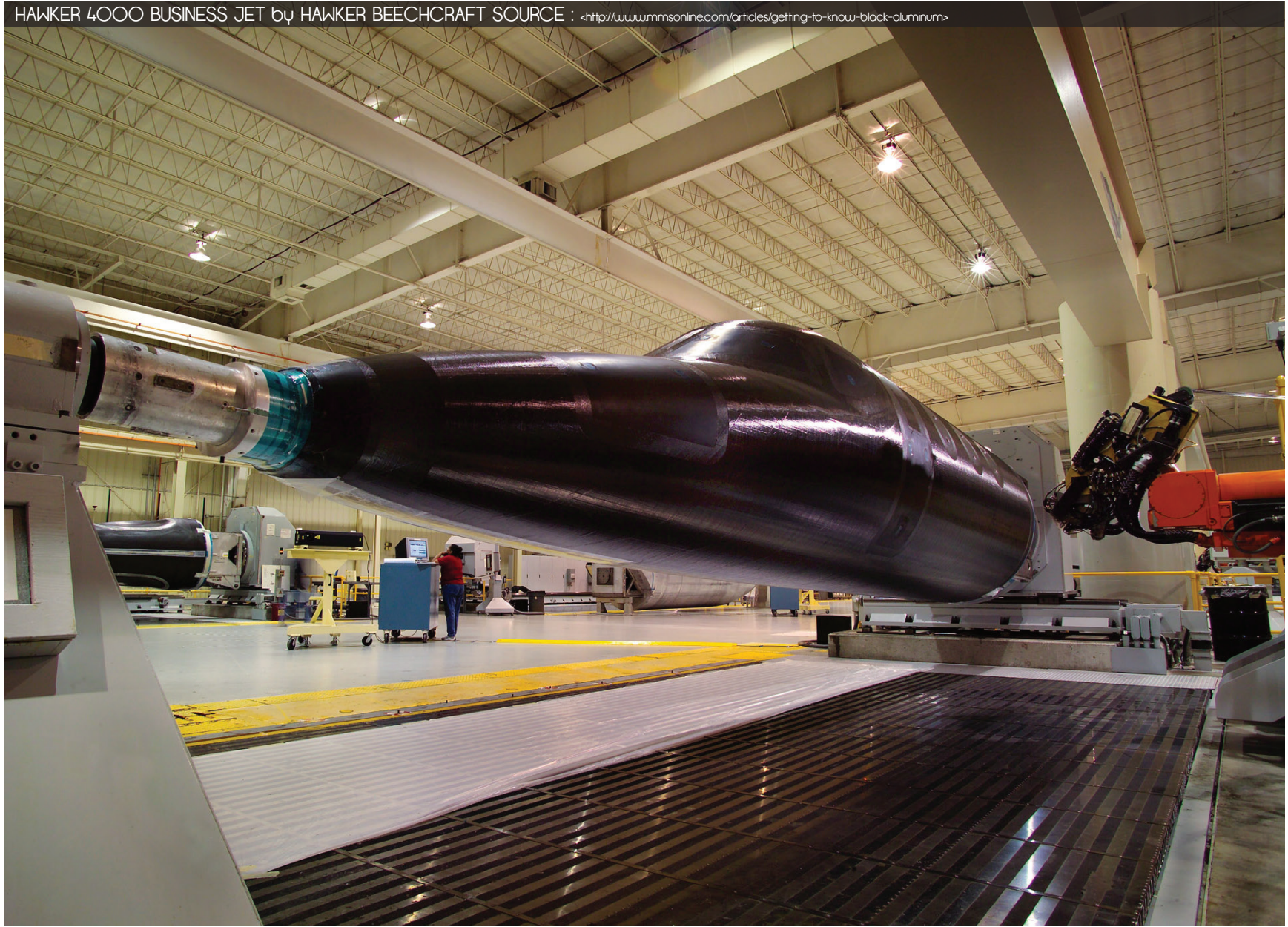

DIGITAL MANUFACTURING

The possibility of a 100% petroleum based house has only become feasible within the past five years as digital manufacturing and ideas of mass customization have become mainstream. For example, automated fiber placement has allowed for the first fully composite fuselage, eliminating the more typical manually intensive processes. The benefit of this transition from manual to automated is clearly demonstrated by automobile assembly lines, which are becoming more autonomous each year. The digital manufacturing paradigm has allowed the efficiency and accuracy of robotics to accelerate production in many fields, and will soon become fully manifested in the way we construct homes.

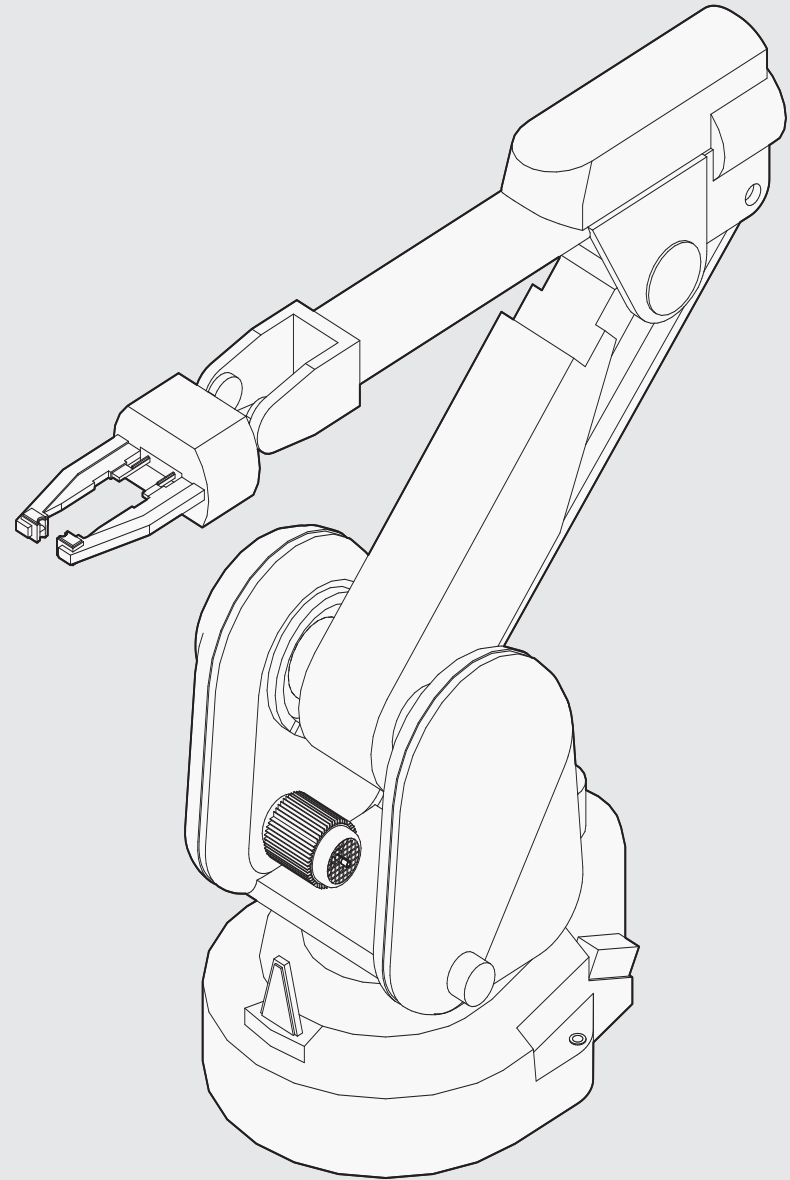

SURFACE DISCRETIZATION

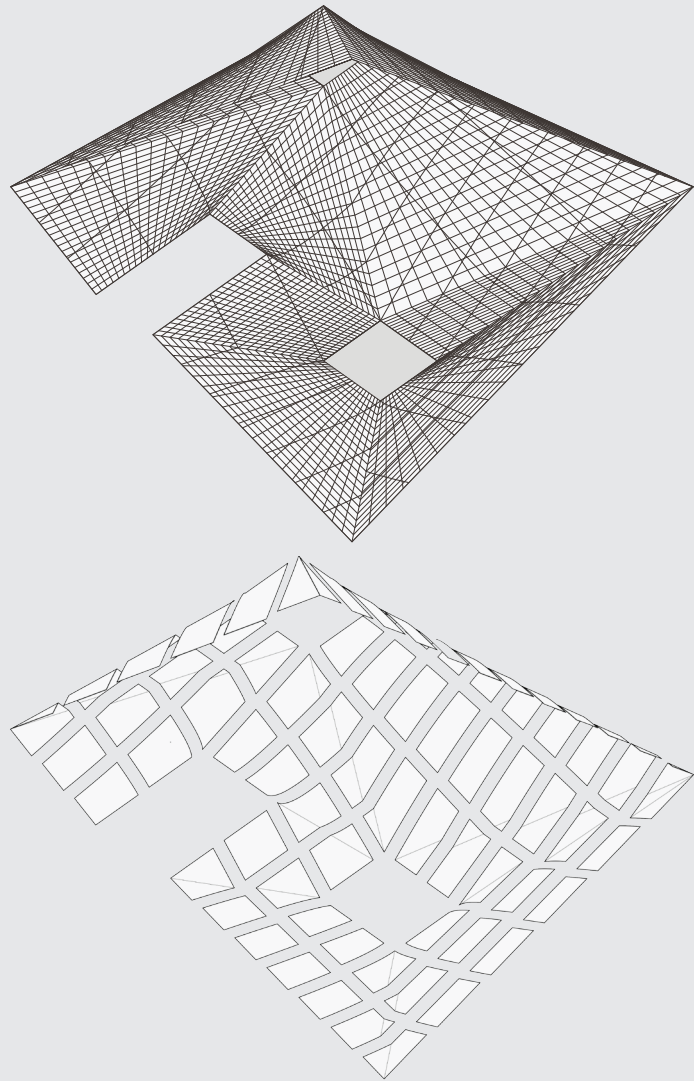

RECONFIGURABLE MOLD WITH VARIOUS SURFACES

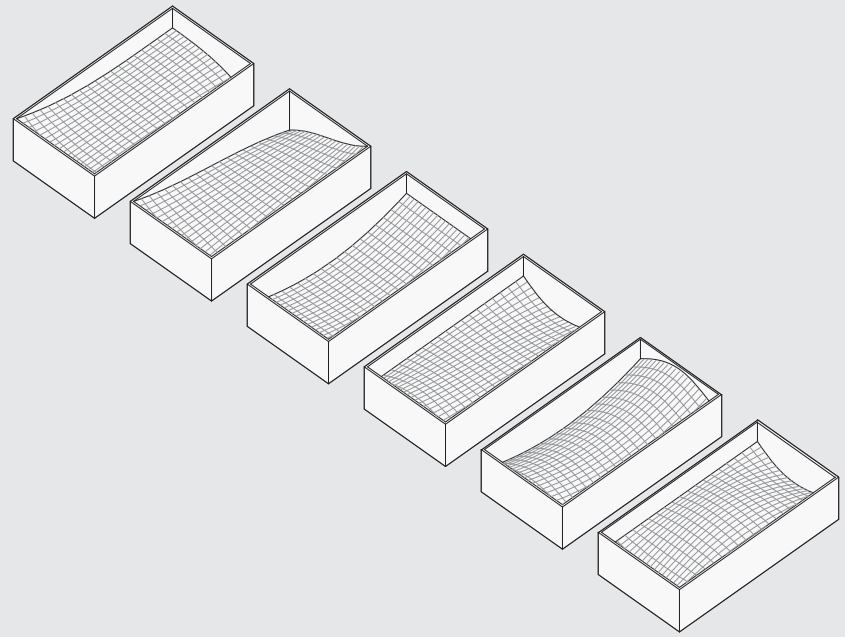

RECONFIGURABLE MOLDS

Molds have been a large inhibitor to the integration and deployment of composites, particularly at a large scale, due to high costs and slow production times. However, as a result of digital manufacturing, molds are becoming cheaper and faster to produce. Innovation in mold production has been the deciding force on whether composites can become mainstream.

One innovation that is beginning to emerge, is the potential for molds that are reusable and even reconfigurable. This opportunity or possibility to produce multiple composite parts from the same mold, has been crucial as seen by the Monsanto House experiment. However, this possibility has only just begun to emerge. If we can begin to program molds and automate this aspect of composite production, they will become much cheaper and faster to produce.

This notion of a reconfigurable mold has few precedents. For example, in Nevada massive molds that are digitally programmed are producing yacht sails in which the geometry and the fiber placement of each sail is custom to the racing yacht. All sails are very similar in geometry and size but still vary in dimensions and depth.

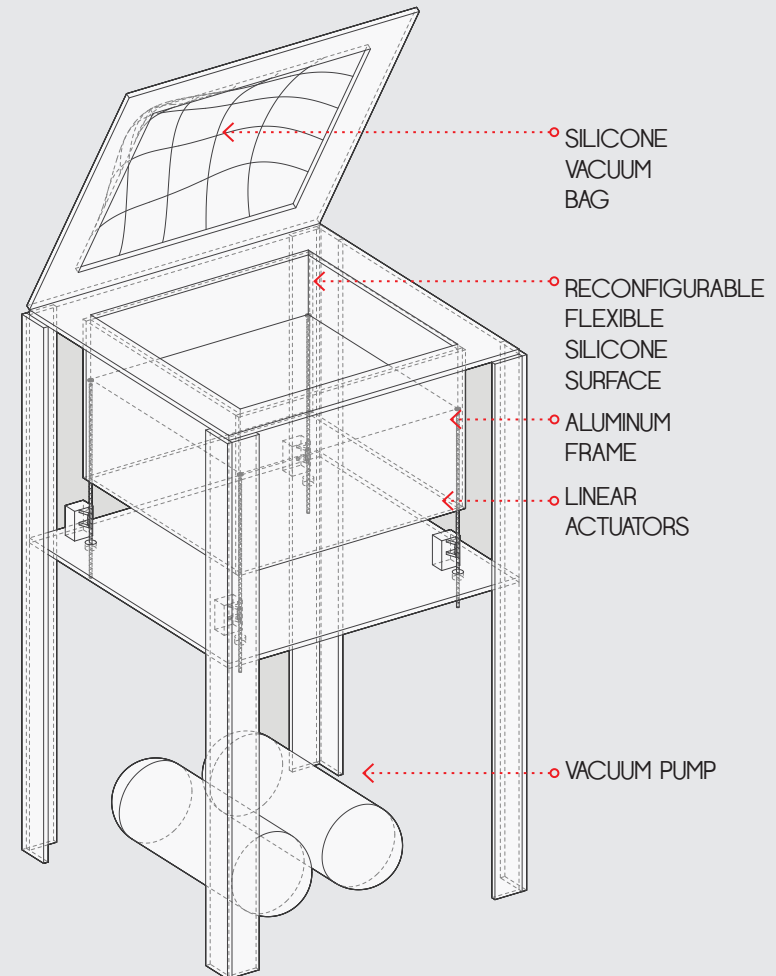

CMU WALL SECTION

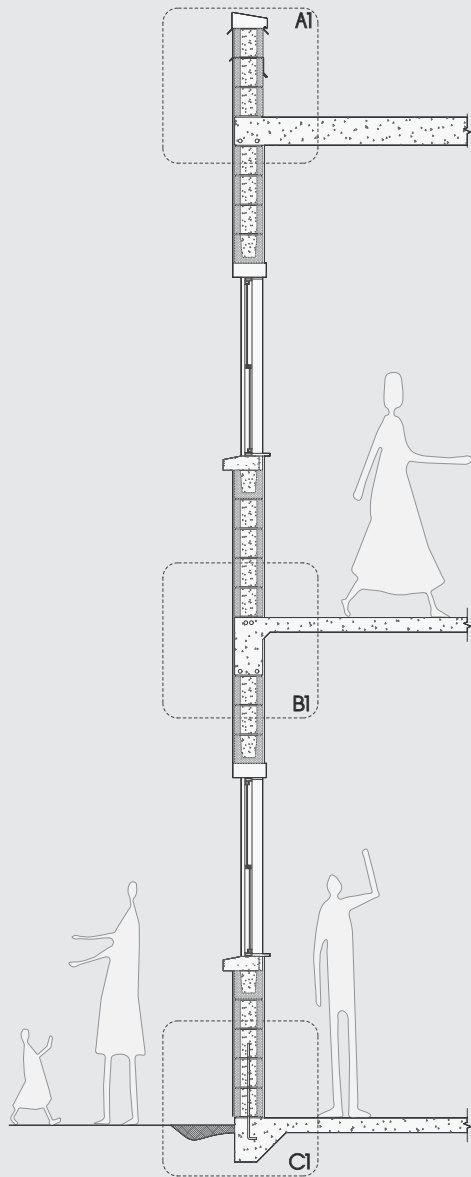

WOOD STUD WALL SECTION

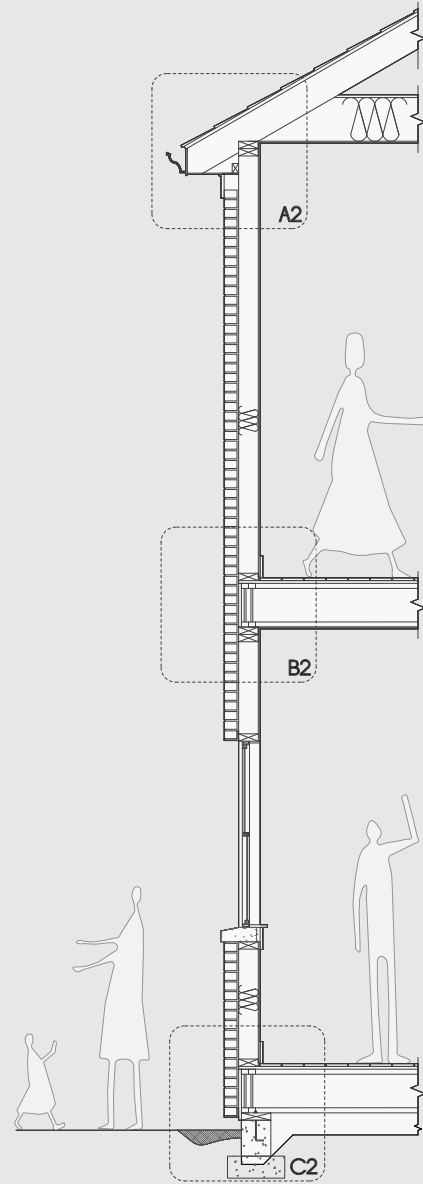

WALL SECTIONS

In order to understand how a 100% plastic/composite house would work, I began by drawing the typical residential wall sections. I considered both a load bearing CMU wall with concrete slabs, and a wood stud wall with a brick facade and compared these with a potential composite wall section. I chose to focus on three comprehensive conditions: the wall to foundation, the wall to floor slab and the wall to roof condition. My understanding of these three conditions in terms of waterproofing, as well as various load transfers, helped inform the design of my Case Study House.

COMPOSITE WALL SECTION

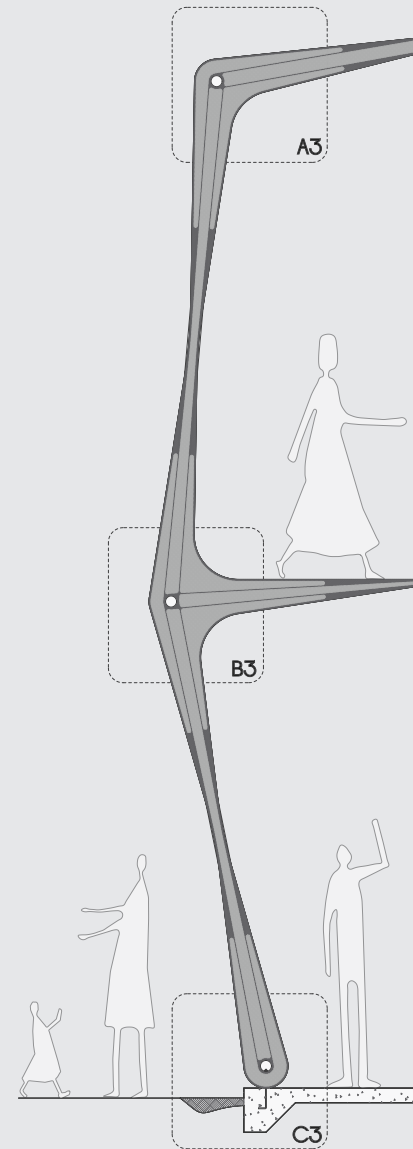

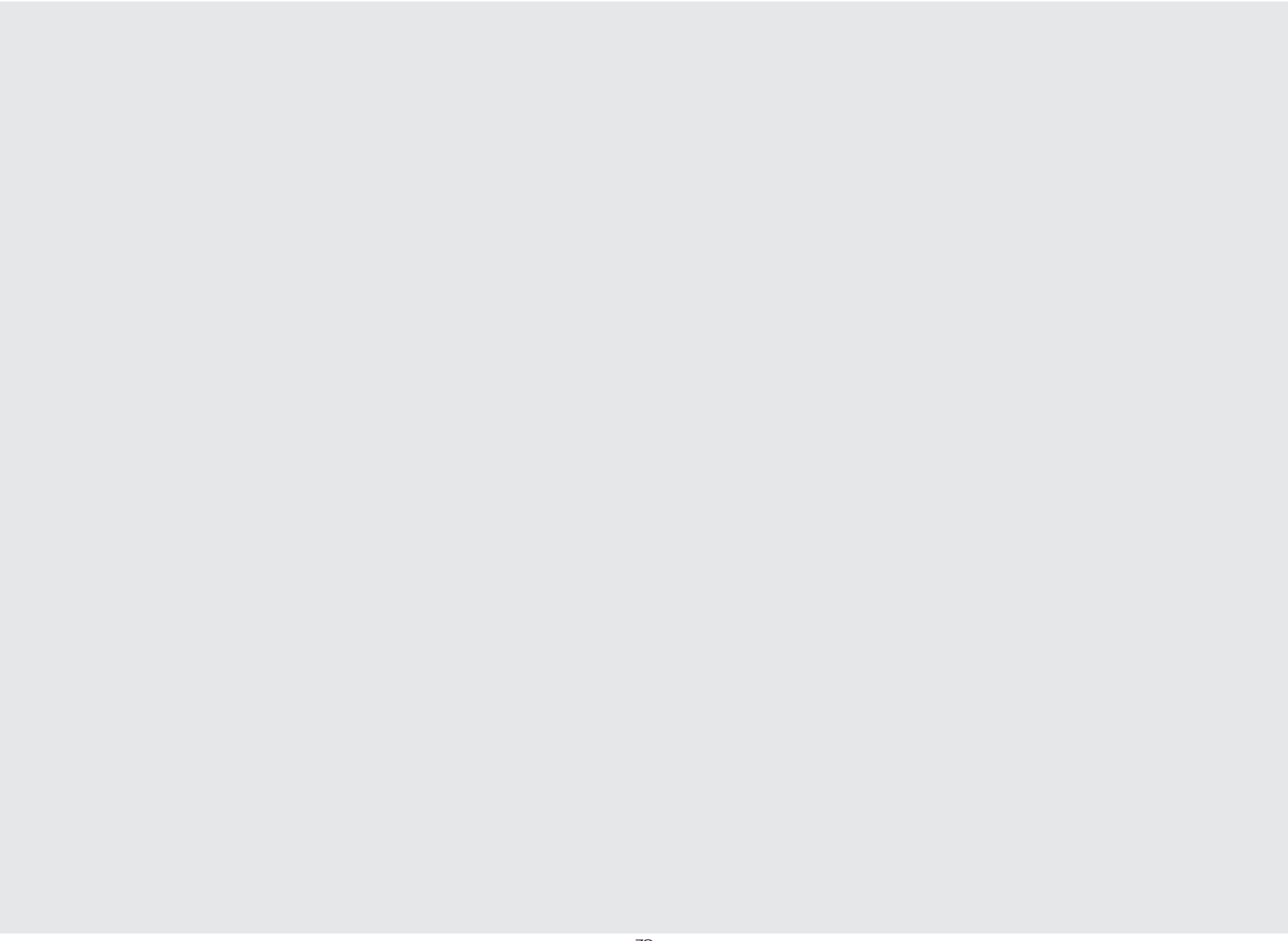

O3 // CULTURAL

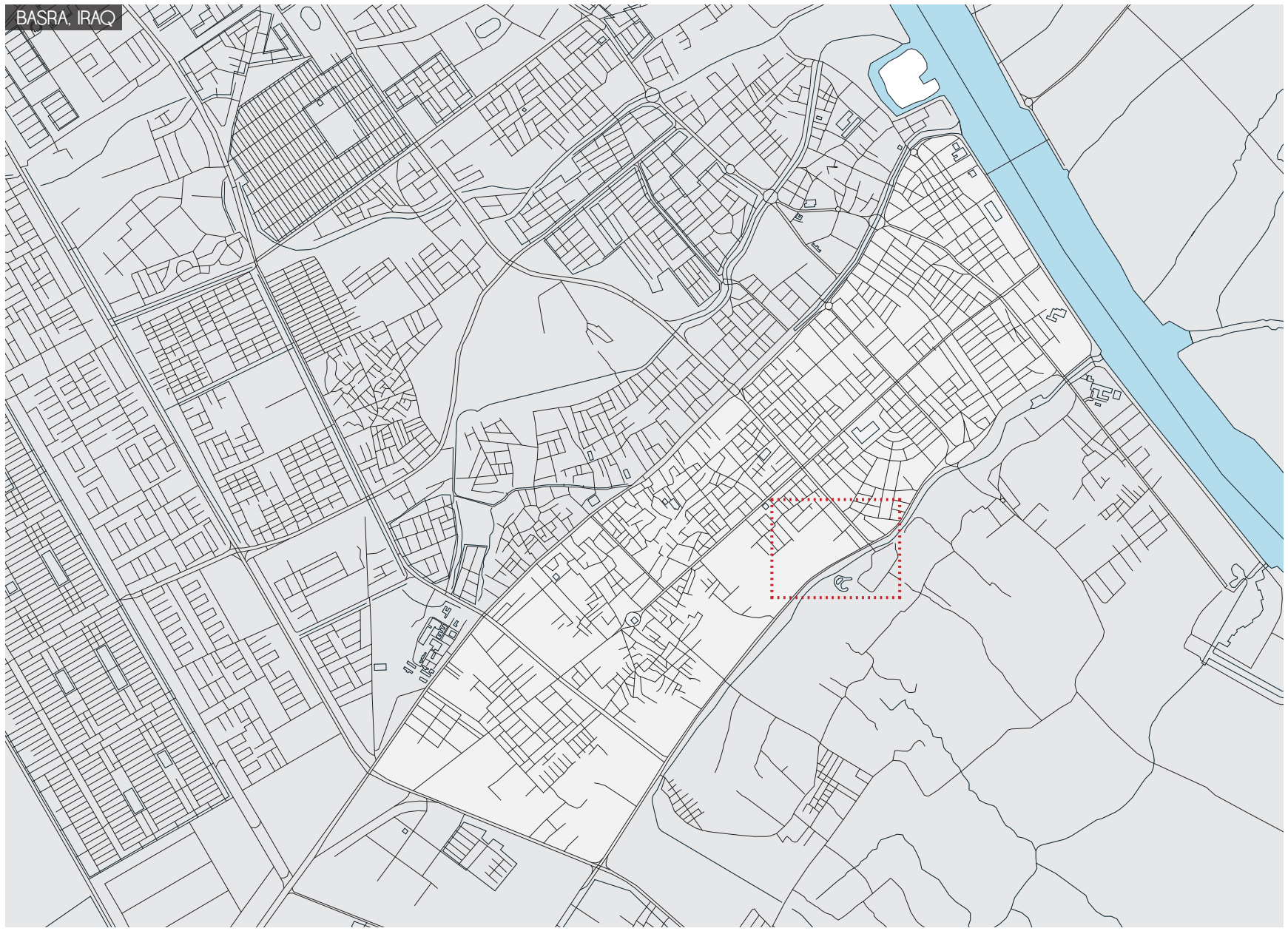

BASRA, IRAQ

From a socio-cultural aspect, the Case Study House must address issues of Iraqi domesticity, environmental constraints and cultural traditions in order to meet the housing need in Basra. Basra is Iraq's second most populous city and a major port city between the Tigris and the Euphrates. Surrounded by some of the largest oil reserves in the world, Basra will serve economically as the backbone of a recovering nation, therefore it is both a strategic and ideal site for testing the Case Study House.



IRAQI DOMESTICITY

I began by studying the traditional Iraqi dwelling in terms of programs, sizes, adjacencies, general organizations, separations, and boundaries. Some of these boundaries were religious, others were climatic, and some cultural; altogether the house exemplifies the conditions of the society in which it is observed. These intangible aspects of the dwelling define the scope at which the case study house can intervene.

FIRST FLOOR

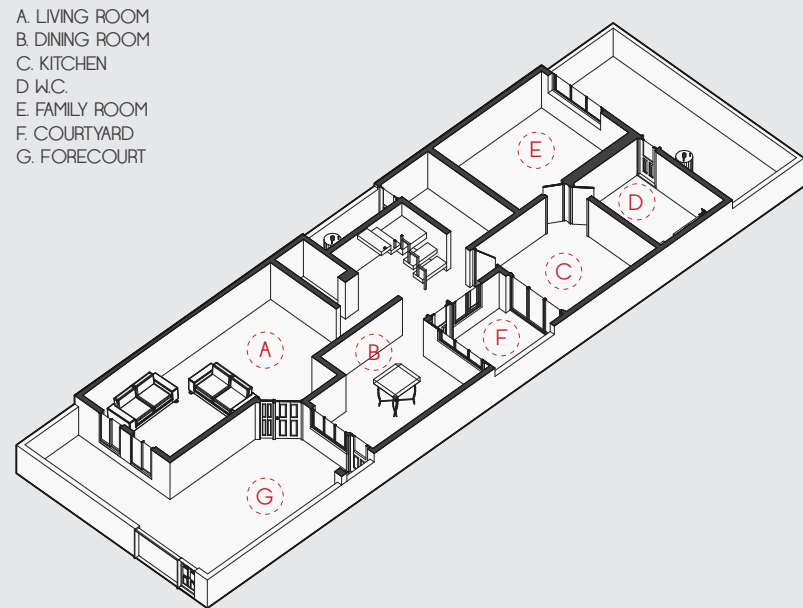

SECOND FLOOR

- A. BEDROOM 1
- B. BEDROOM 2
- C. BEDROOM 3
- D. W.C.

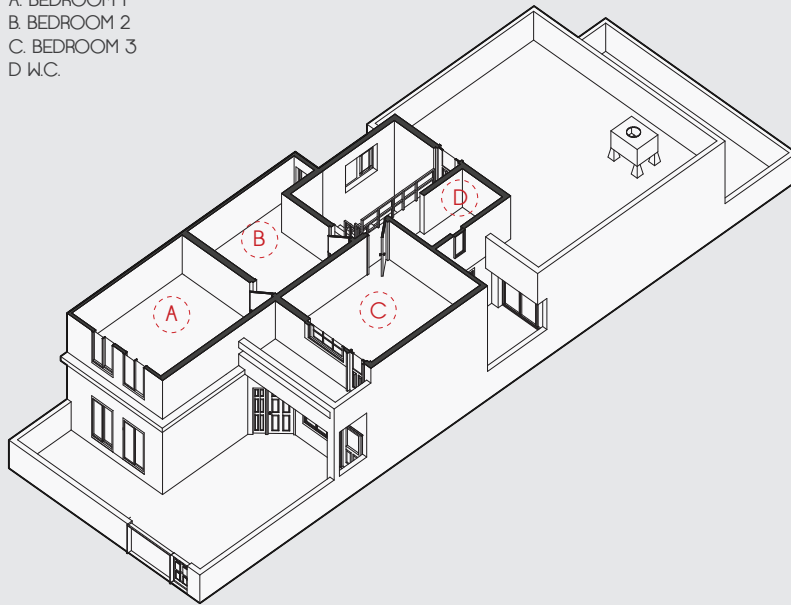

ROOF ACCESS

- A. ROOF ACCESS
- B. PORCH

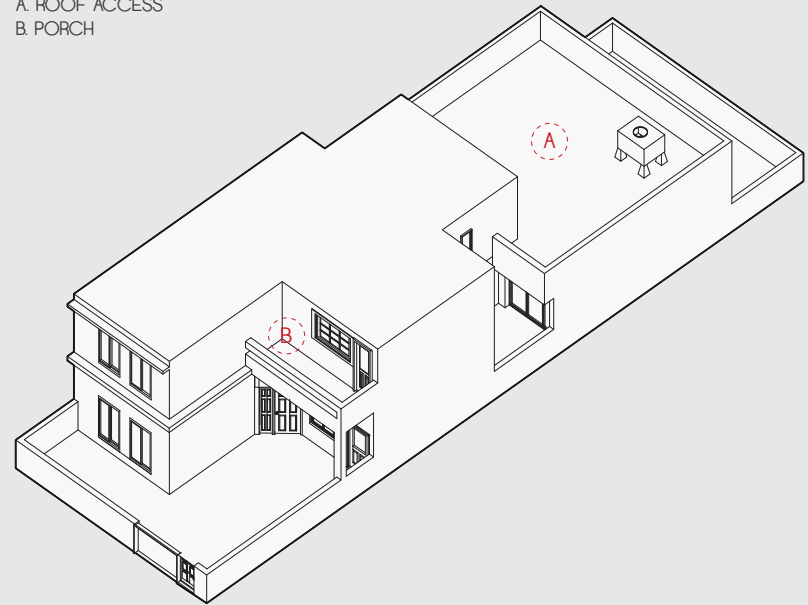

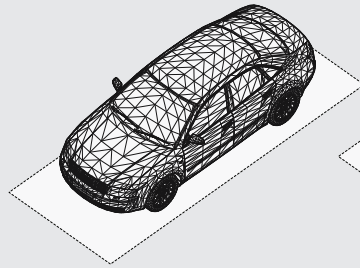

PARKING [8 SQ M]

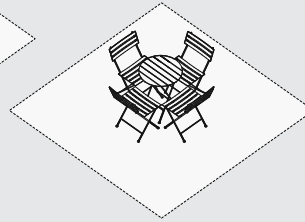

FORECOURT [9 SQ M]

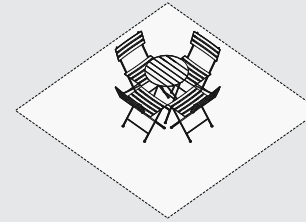

INTERNAL COURT [9 SQ M]

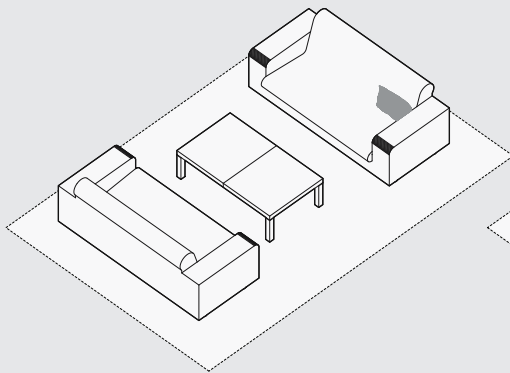

LIVING ROOM [20 SQ M]

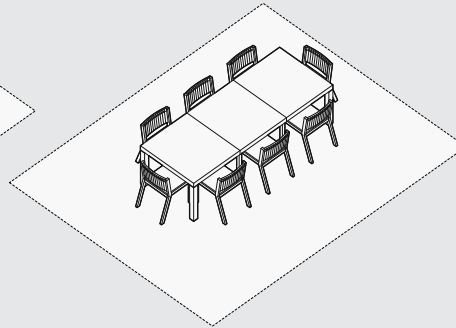

DINING [20 SQ M]

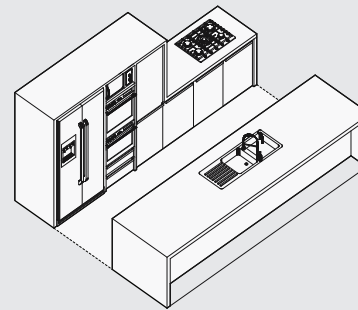

KITCHEN [12 SQ M]

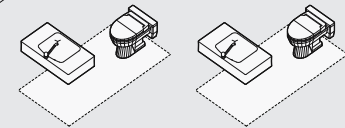

1/2 W.C. [2 SQ M] 1/2 W.C. [2 SQ M]

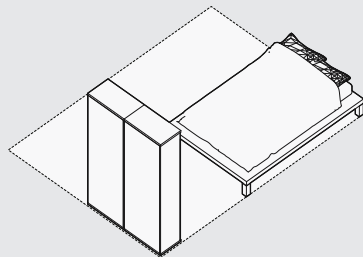

BEDROOM 1 [12 SQ M]

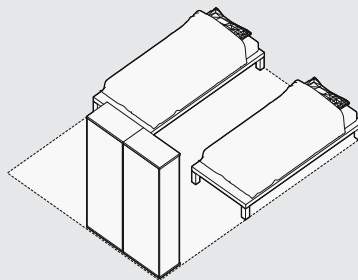

BEDROOM 2 [12 SQ M]

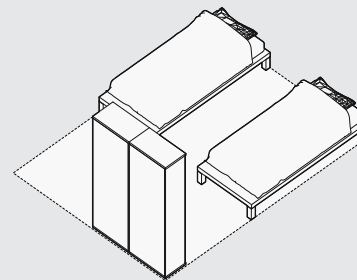

BEDROOM 3 [12 SQ M]

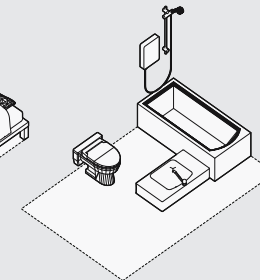

W.C. [6 SQ M]

PROGRAM

Combining these notions of the traditional dwelling with requirements that were put forth by the National Investment Commission for Iraq, determined the general program, as well as the approximate sizes of the various spaces. The National Investment Commission for Iraq was established to assist and guide anyone interested in investing in the reconstruction and development of Iraq. For each market sector, the National Investment Commission (NIC) sets regulations and guidelines in order to control the types of investment coming into the country. Under the housing sector, the NIC lays out the specific guidelines in regards to program, financing, infrastructure, etc. They are as follows:

The Housing Units would be required to comply with certain basic criteria in considering size, layout, energy efficiency, construction material et.al. We believe that, in light of the housing shortages and the available plots of land in urban environments, the likely requirements in such areas would be that the units area between 100 to 150 square meters (containing, at a minimum, three bedrooms, living room, bathroom, kitchen, and storage area).

We currently propose that the target sales price for each housing unit will not exceed fifty thousand US dollars (\$50,000USD, given 100 square meter unit) or \$500USD per square meter.

In light of Iraq's housing shortage, the NIC will look favorably on Developers who intend to complete their proposed projects using modern building technologies, which would be anticipated to complete such Developments in a more timely and cost-efficient manner than the traditional building processes utilized in Iraq. Developers should note, however, that the NIC will review such modern technologies to ensure that quality would not be affected and that the materials and de-

signs will be specific to regional requirements and market demands.

The dwelling should incorporate a forecourt to serve as transitional space between the street, and the dwelling. In addition, it should capitalize on the traditional Iraqi internal courtyard which provides privacy for families, as well as safety for children. The interior of the dwelling should reflect the cultural issues of privacy by strictly separating public, and private programs. The public programs include: the forecourt, the front living space, and a shared restroom. The private program includes: 3 bedrooms, an internal courtyard, and a private restroom. Usually the private and public programs are separated by the dining room.

EXTERIOR OVERHANG

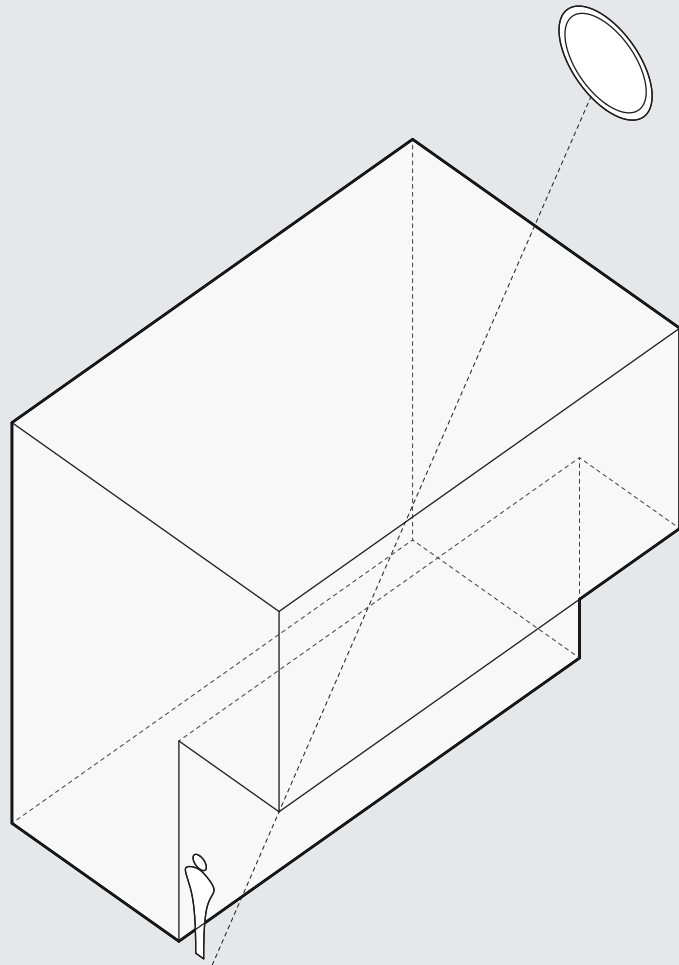

CROSS VENTILATION

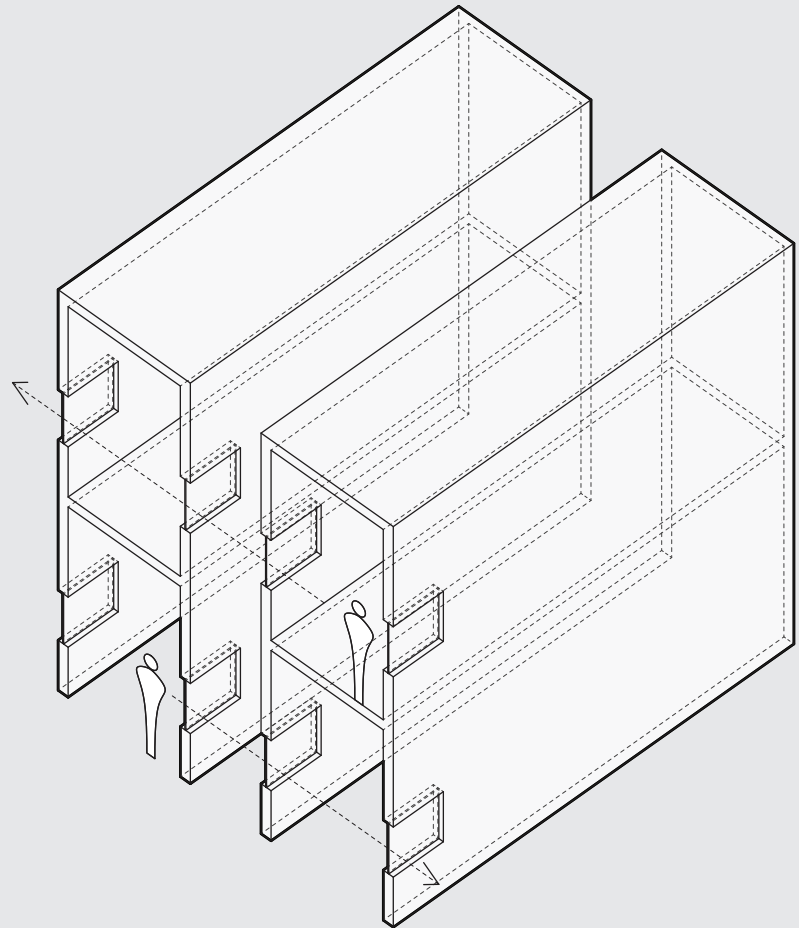

ENVIRONMENTAL CONTEXT

Basra has a hot desert climate, so environmental considerations for a dwelling should include: exterior overhangs, cross ventilation, shaded light wells, double height wind towers for air circulation, shaded courtyards, night cooling, exposed thermal mass, an airtight insulated envelope, natural ventilation, summer full shading with solar access in winter, water conservation, and low cost waste management.

BASRA IRAQ SOURCE : <http://www.glogster.com/ash08131998/oil-non-renewable-resources/g-614p-po5d08of61l6pukasa0>



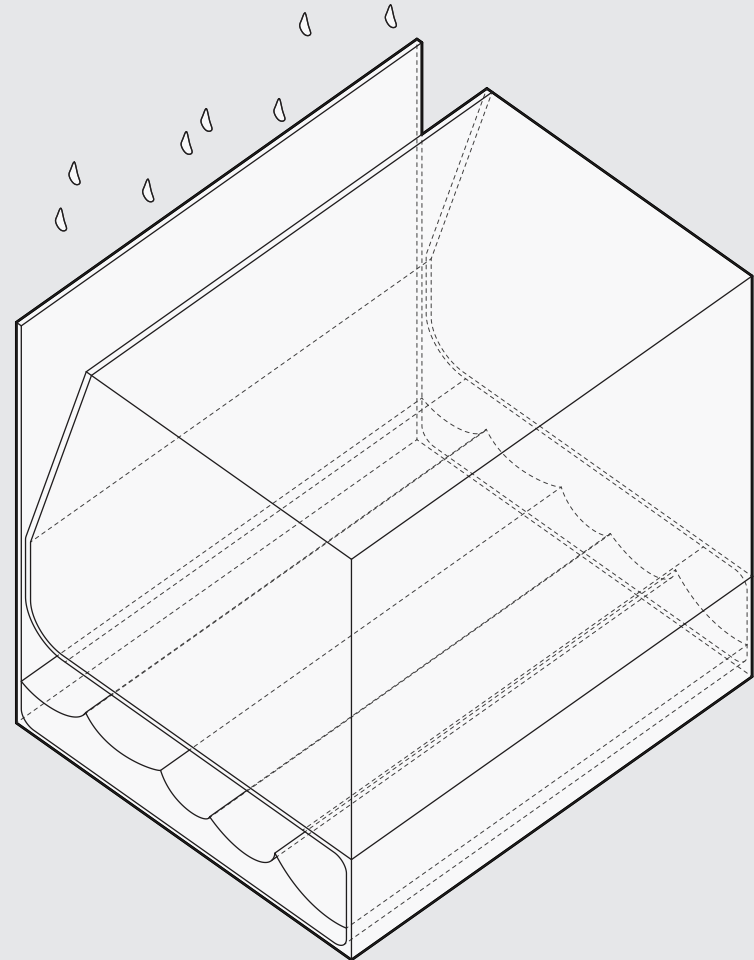
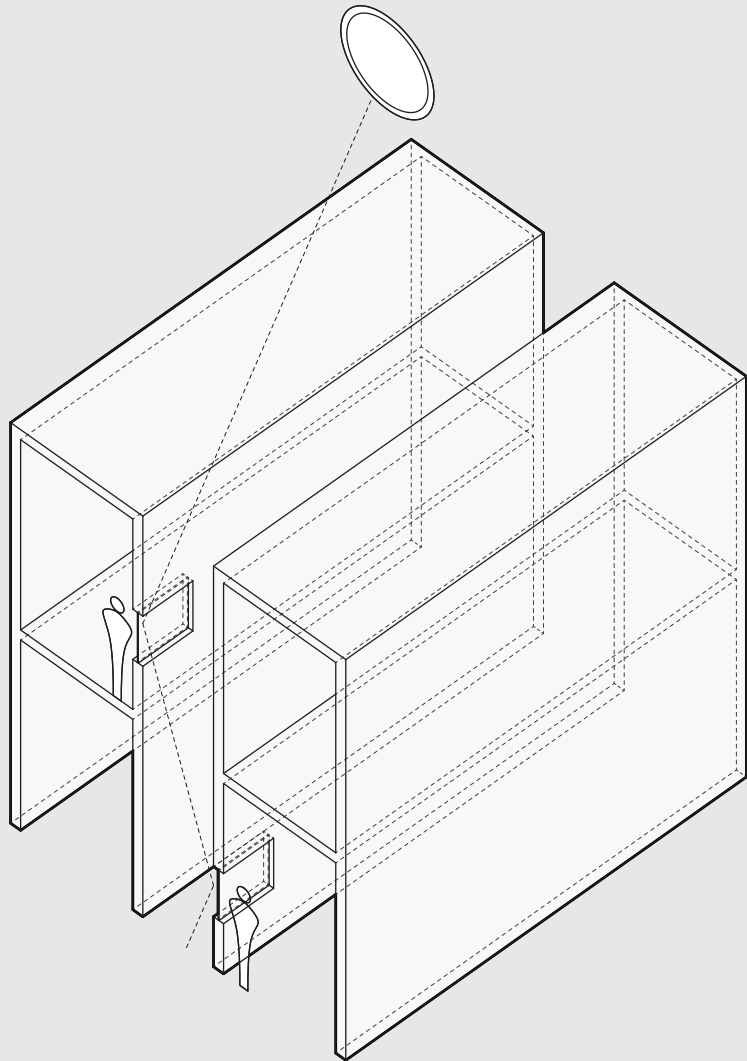

SHADED COURTYARD

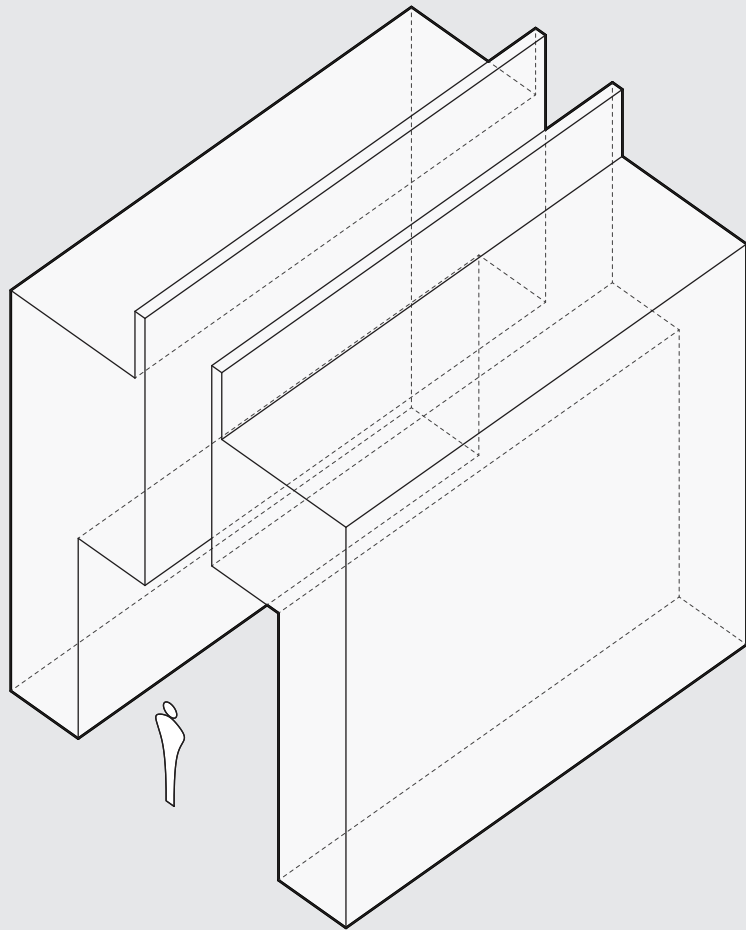

COOLING TOWER

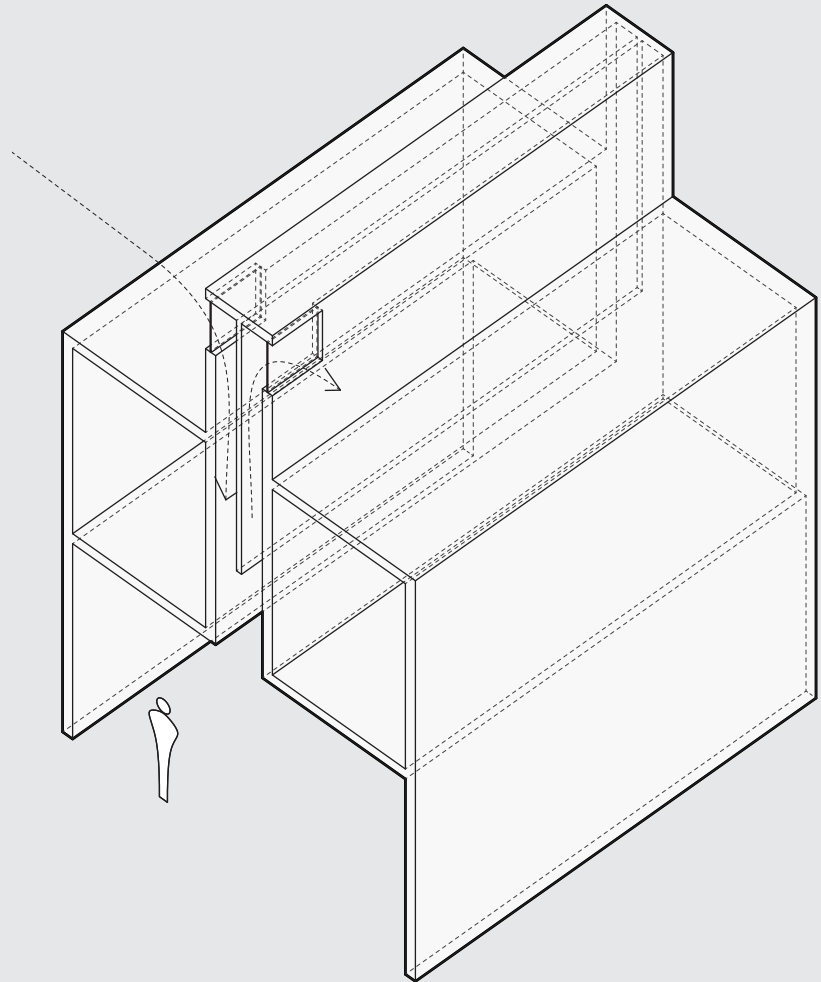

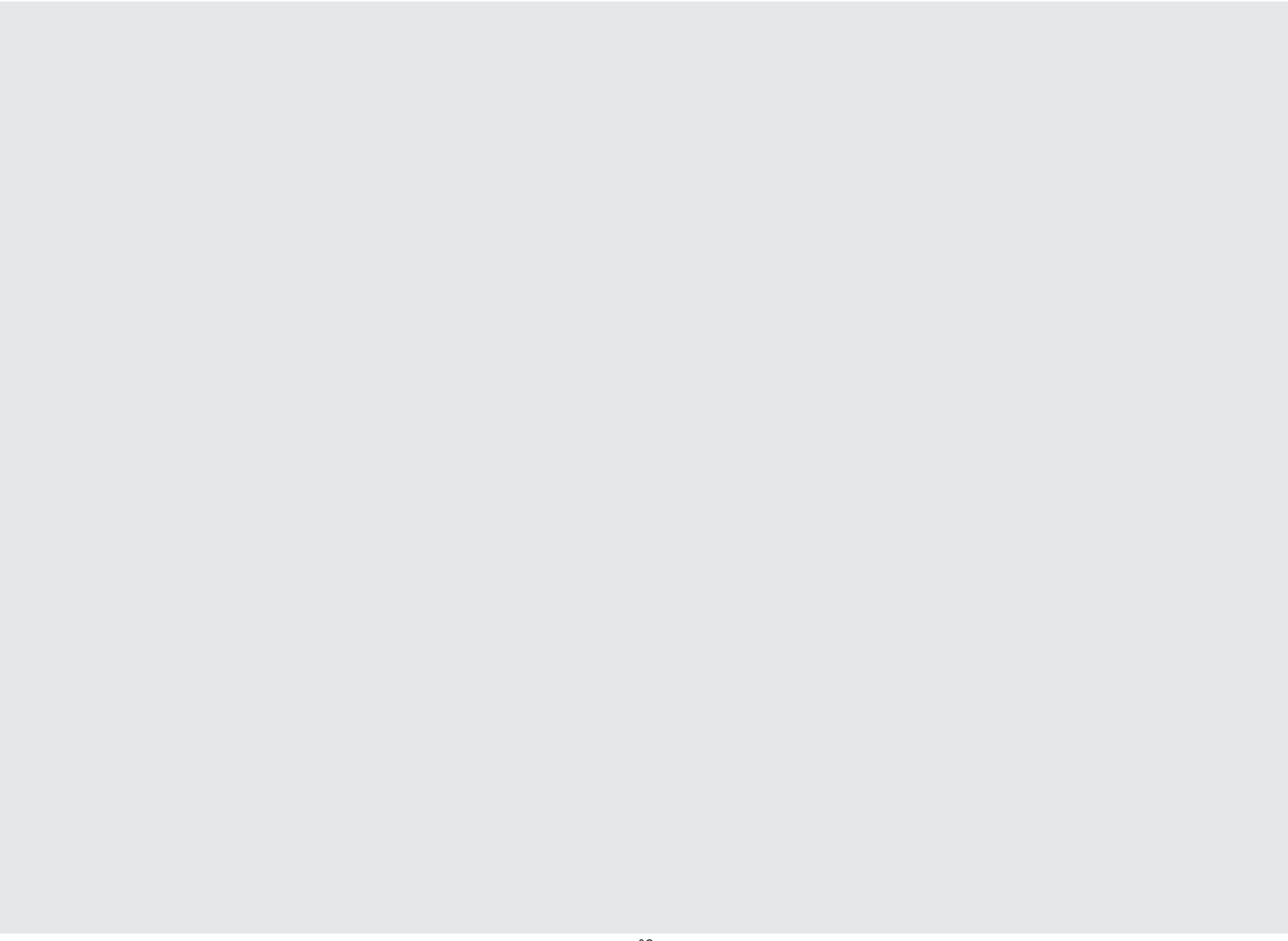

O4 // DWELLING

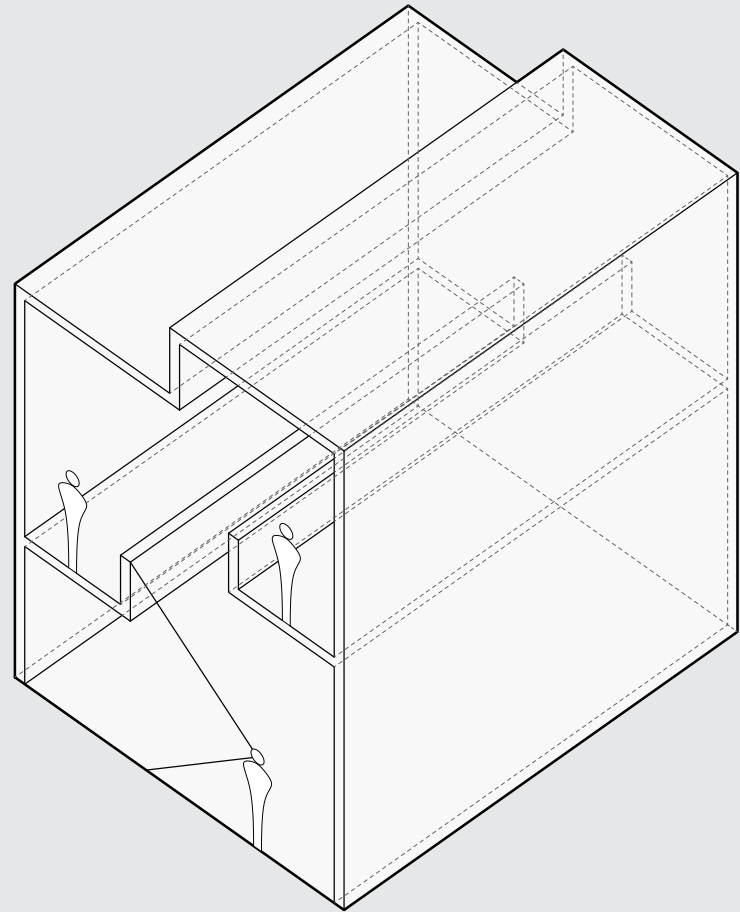
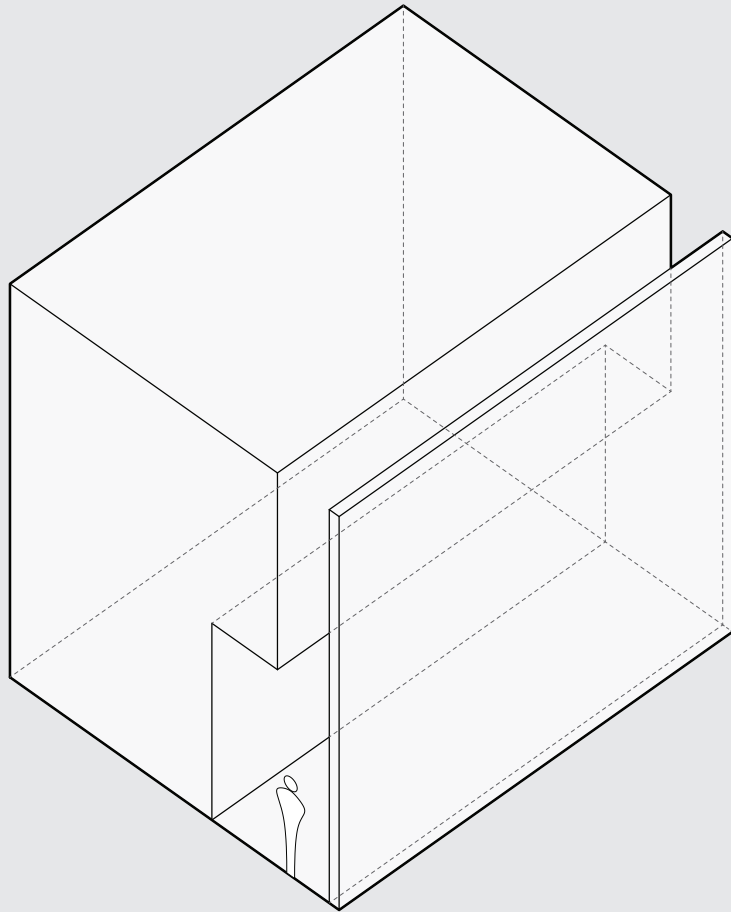

DWELLING

In an effort to transition these concepts of materials, construction and cultural constraints, I began by critiquing the traditional dwelling. Iraqi dwellings are characterized by a strict adherence to the division of private from public; both cultural and religious beliefs reinforce this separation of male and female territories within the house. This division of public and private has architectural implications, resulting in overly compartmentalized plans, made up of vast amounts of corridors and doorways.

The case study house hopes to challenge the traditional notions of division and separation, while respecting the culture and religion. I began rethinking the plan through the geometric development of the dwelling; reorienting the building on site, created a new vertical directionality. This verticality is made possible only through exploiting the many potentials provided by the use of plastic materials. The result is a smaller footprint, and a much taller dwelling in which the program is stacked, with the most public on the ground, and most private on the top.

In addition to the reorientation, I conceived the building as a series of tubes, rather than as one monolithic structure. It is broken down into four carefully sized tubes, and dimensionally amounts to the size of a truck in width, and the length of the truck bed in height. These tubes would be prefabricated nearby, brought to site and assembled; the discretization would make the transportation to and on site easier.

These tubes are then formed and shaped based on various requirements. While the backside of the house is tapered to eliminate unneeded floor space on the lower levels, half of the house is lifted and cantilevered, creating a forecourt, as well as sheltered parking. In addition, the tops of each of the tubes is carved out to create light wells, and pulled down to open up these light wells into a courtyard, with a direct view outward.

In terms of their relationship with the environment, these light wells are derived from the traditional dwelling. Traditionally courtyards, light wells, roof decks, and verandas serve to blur the boundaries between interior and exterior. In Iraq, courtyards serve not just as a means for privacy, but also become inhabitable spaces. Because of the climate, shaded courtyards are frequently furnished with tables and couches, and actively used, in some case more than interior living spaces. The deployment of these inhabitable light wells/courtyards serves to effectively double the livable space.

DOUBLE HEIGHT SPACE

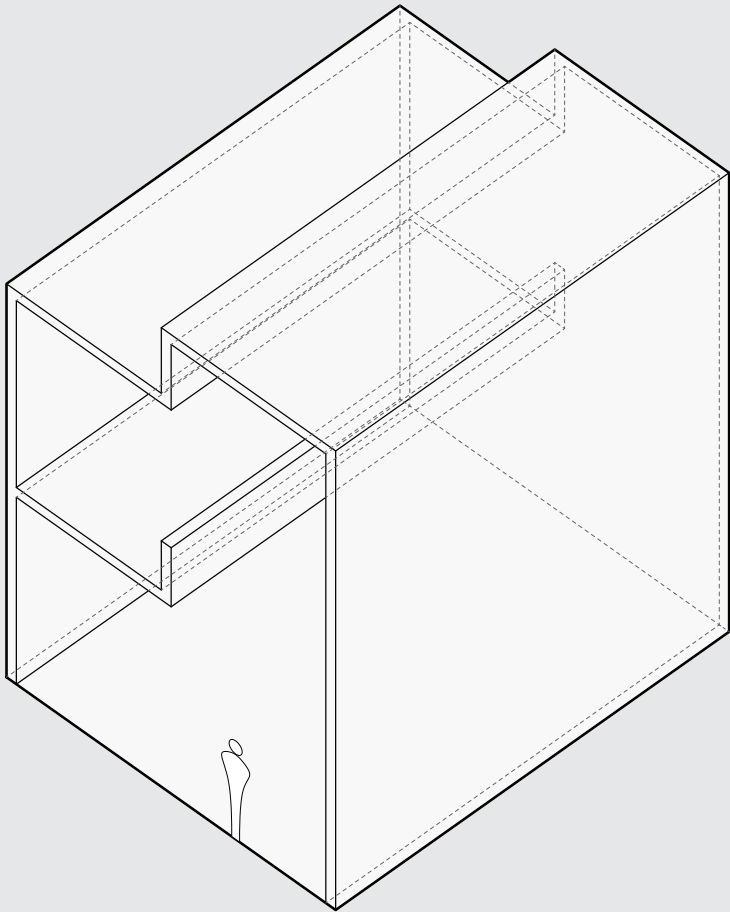

VERTICAL SEPERATION

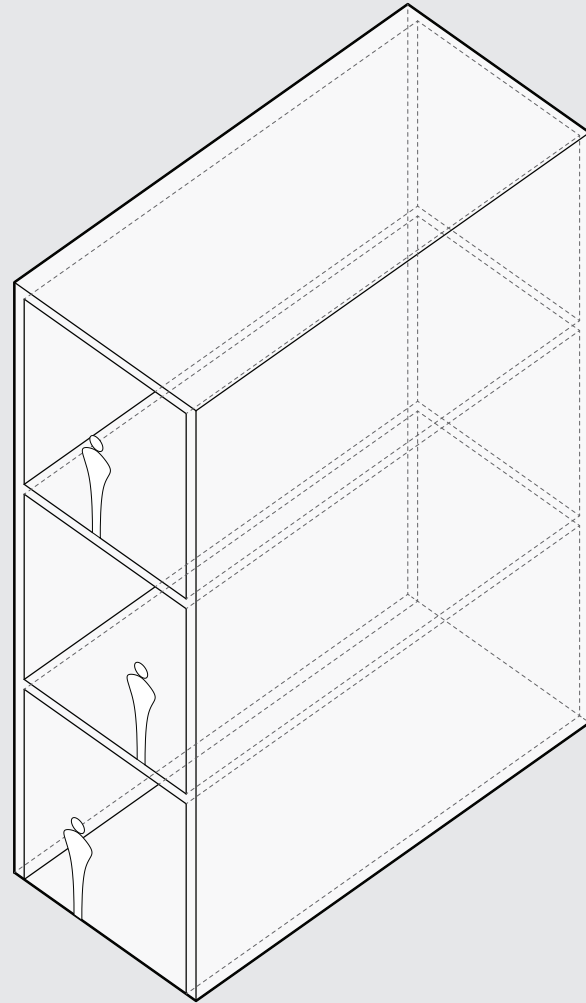

INTERNAL PORCH

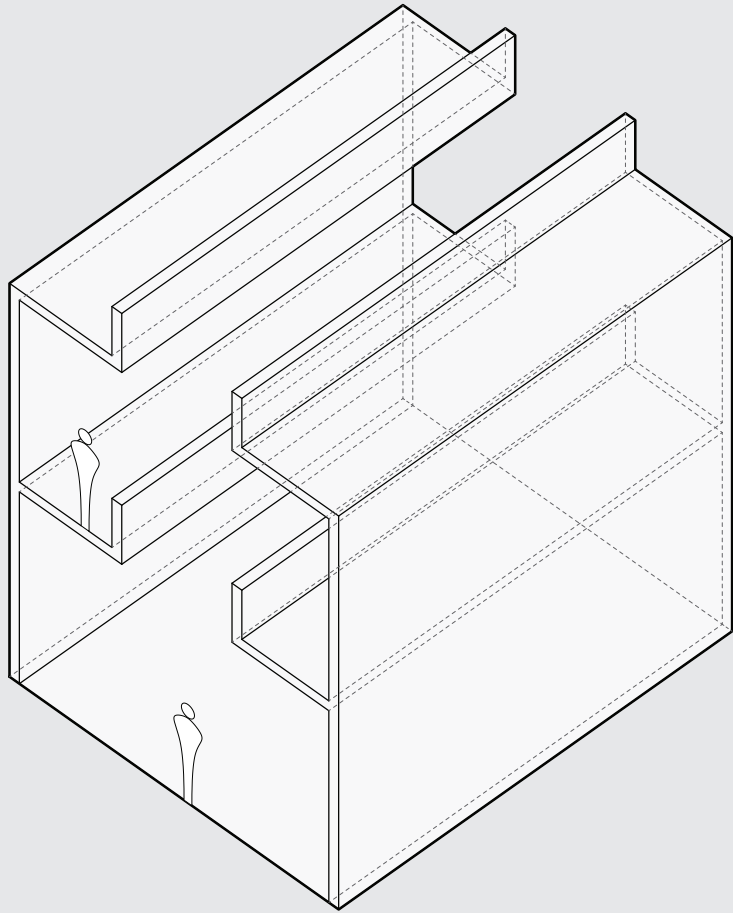

ROOF ACCESS

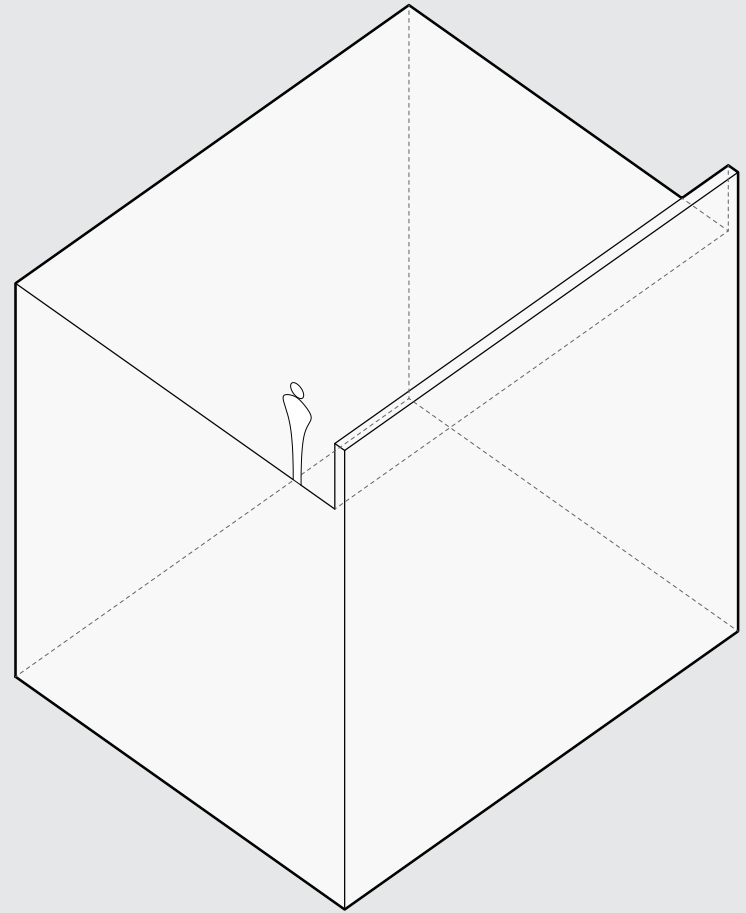

REOIRENT

INITIAL VOLUMNE

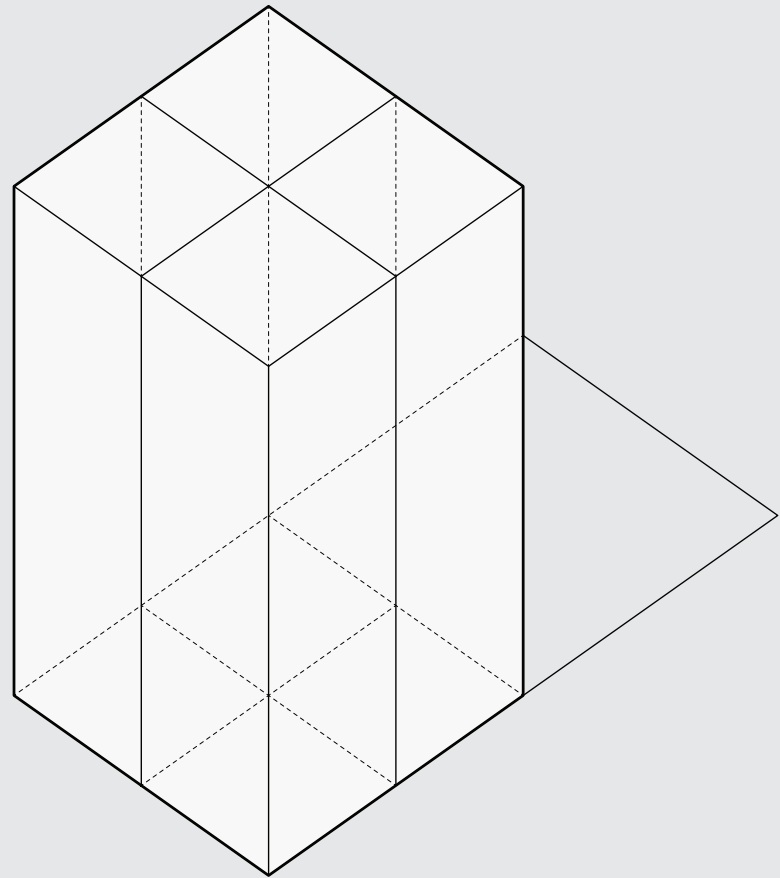
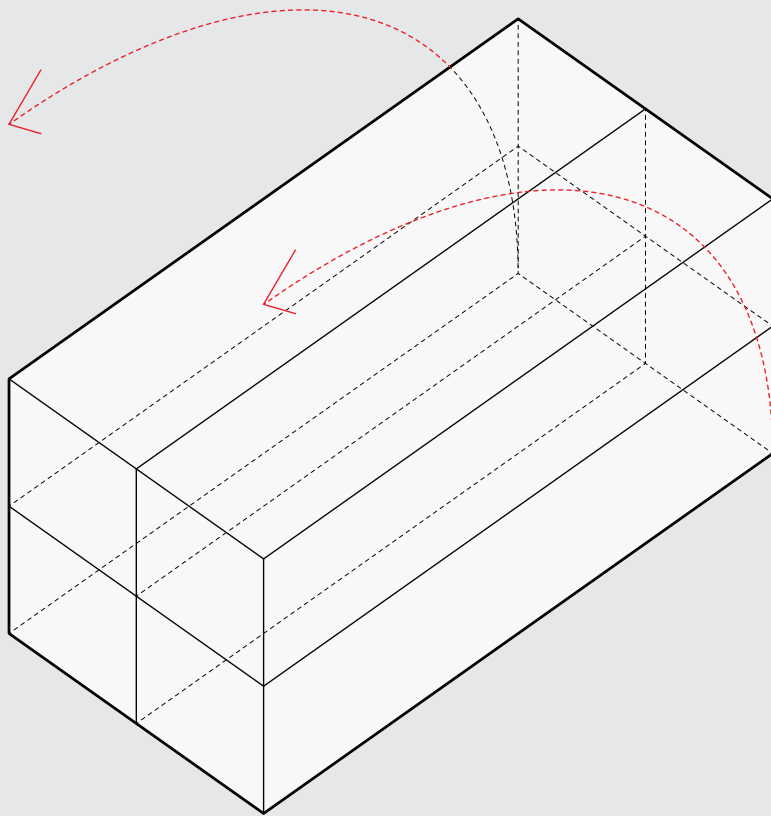

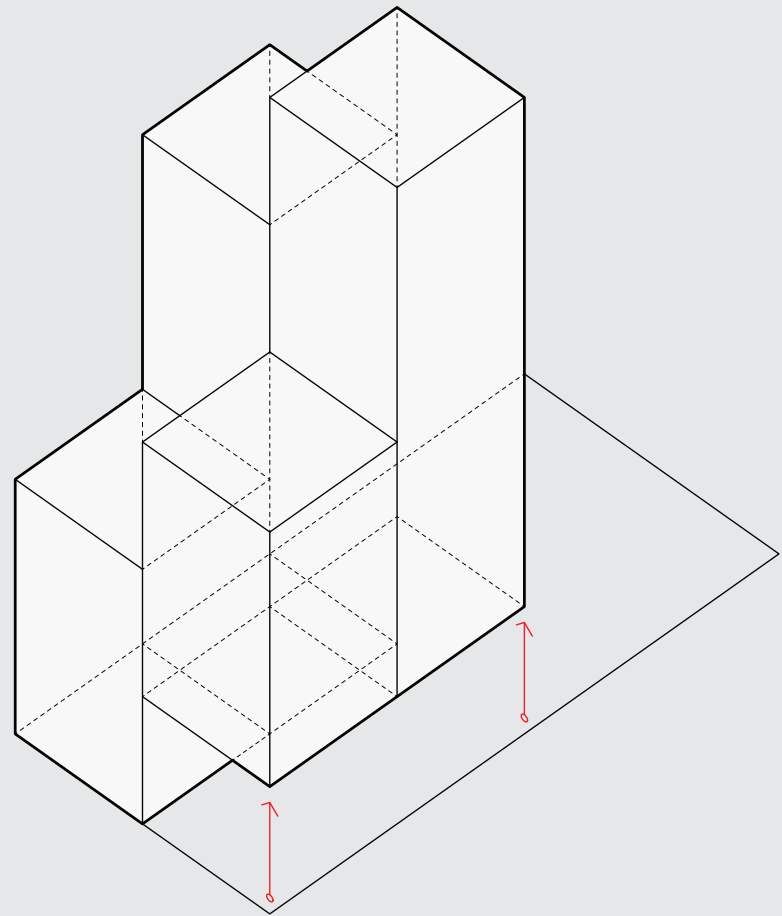
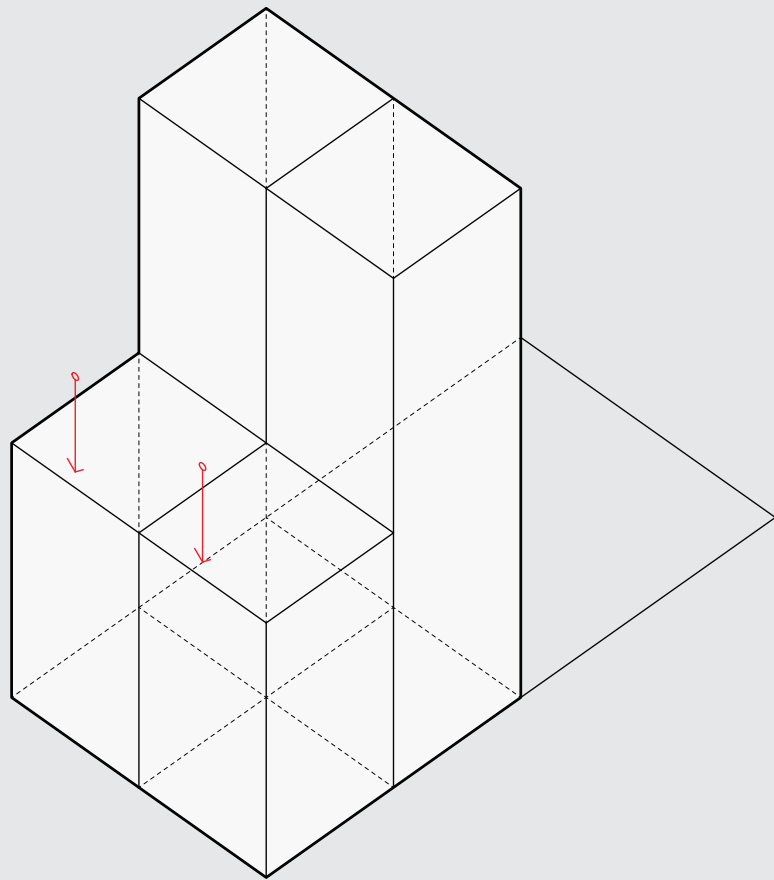

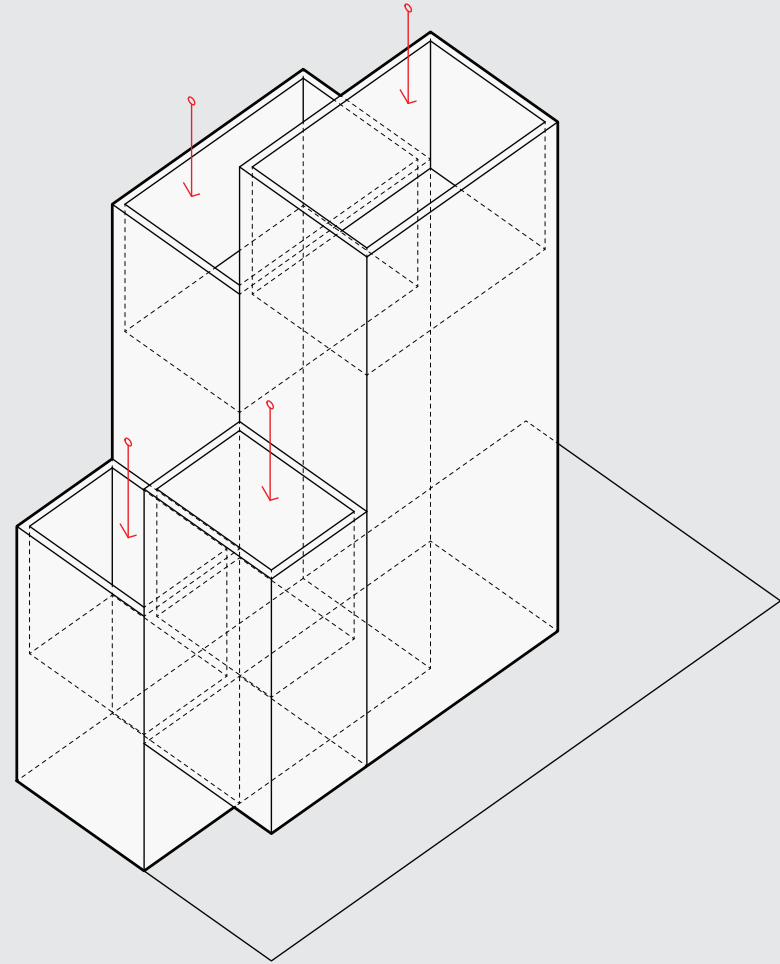
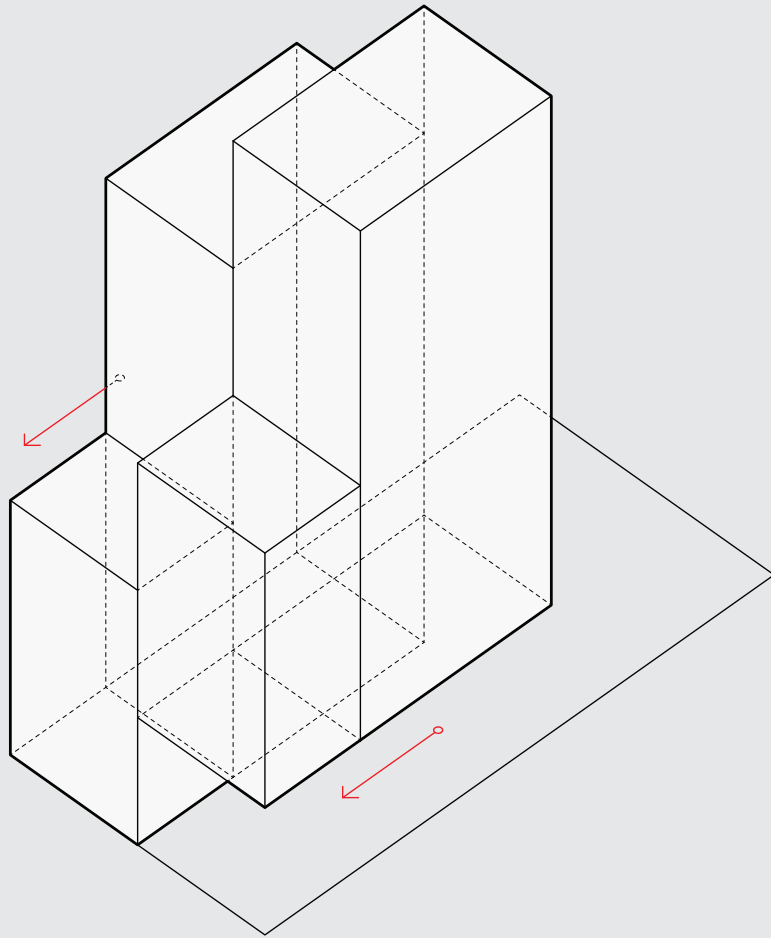

OPEN VIEW

EXTERIOR SHADE

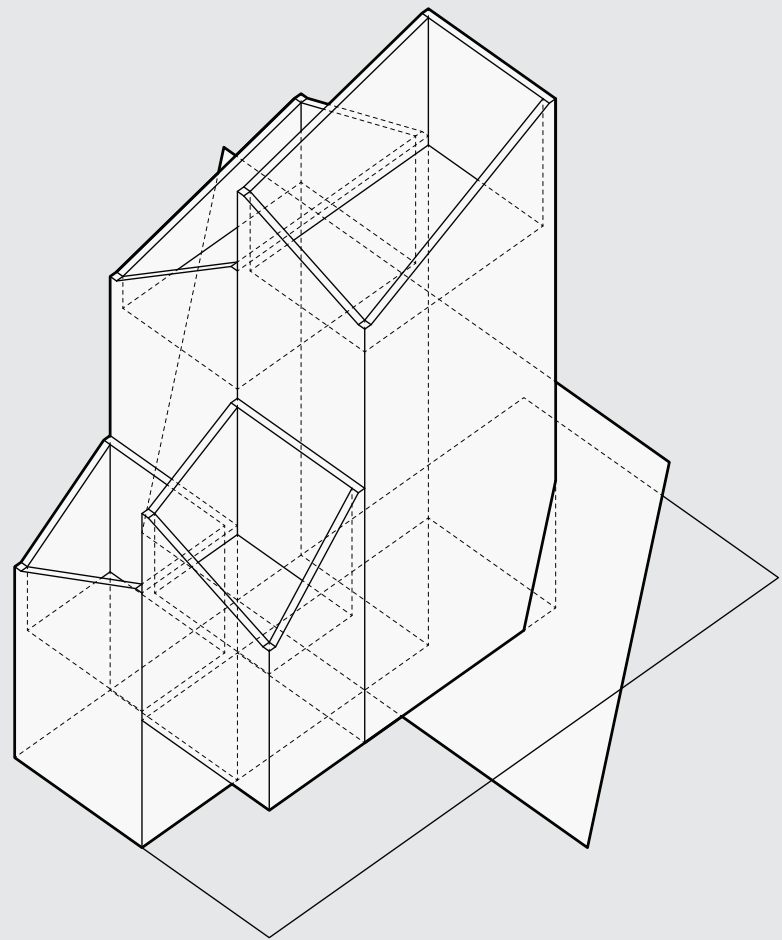
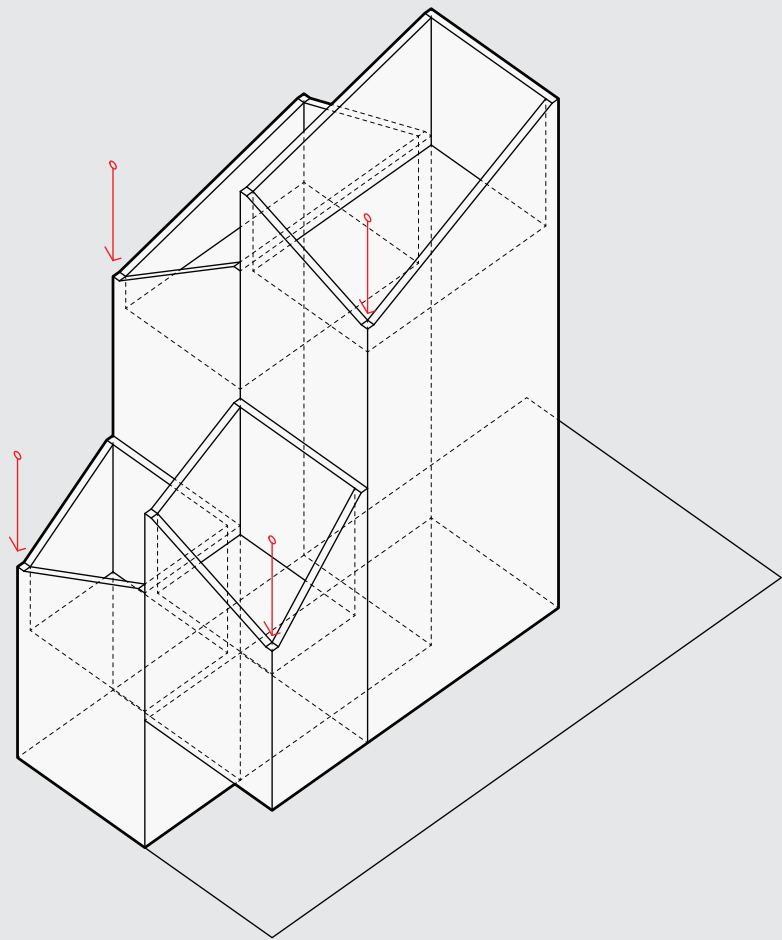

FINAL BASE FORM

PULL DOWN

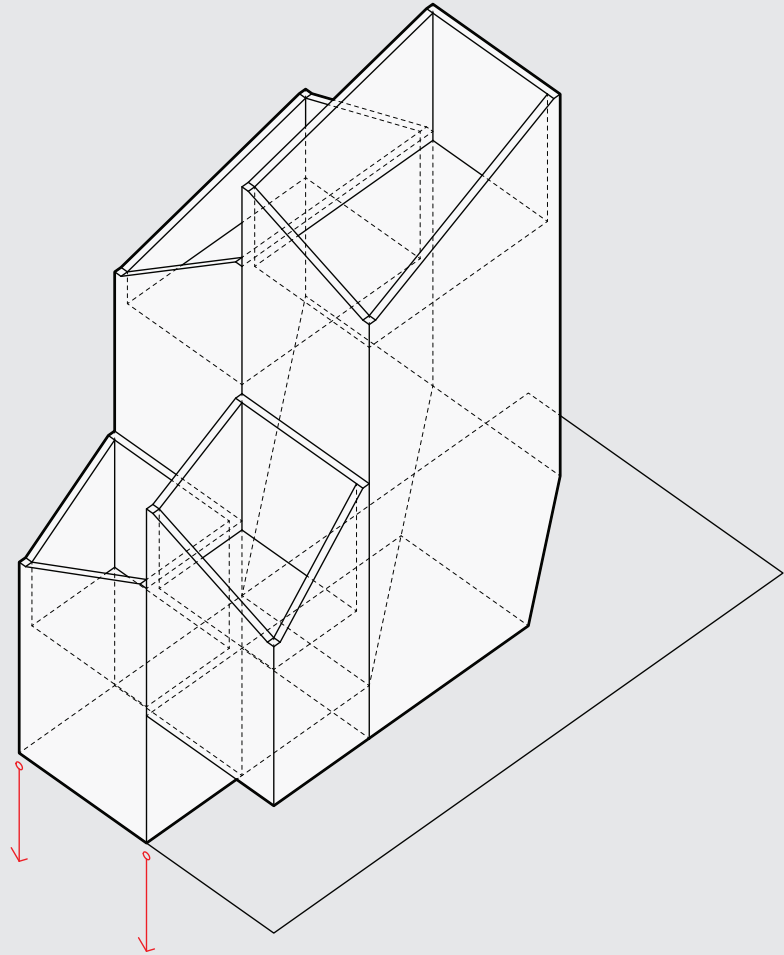
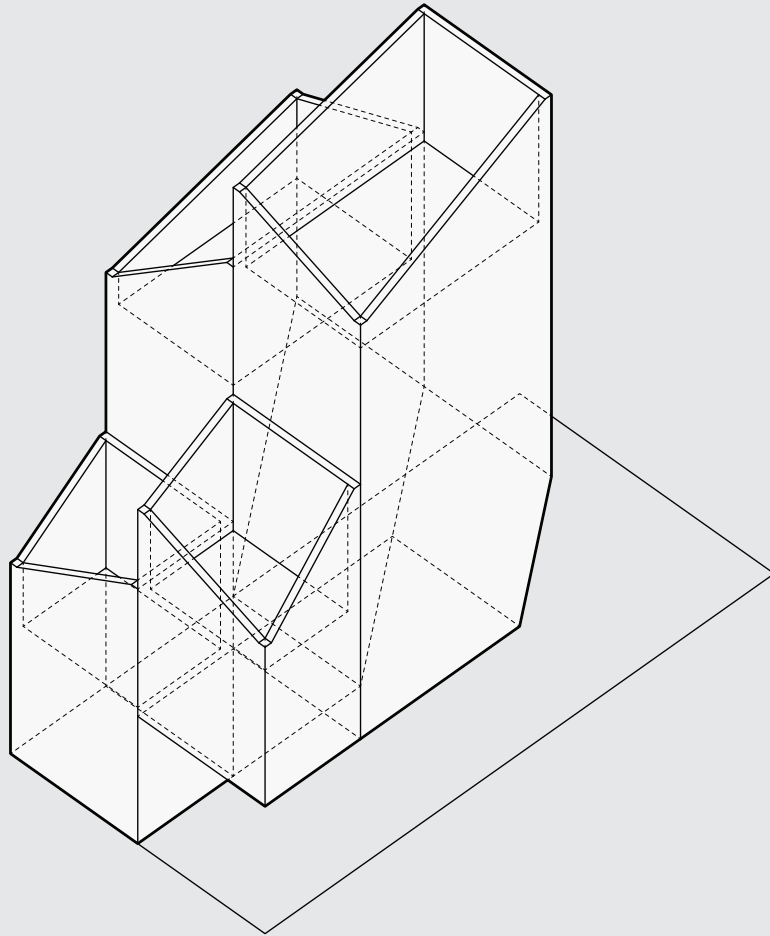

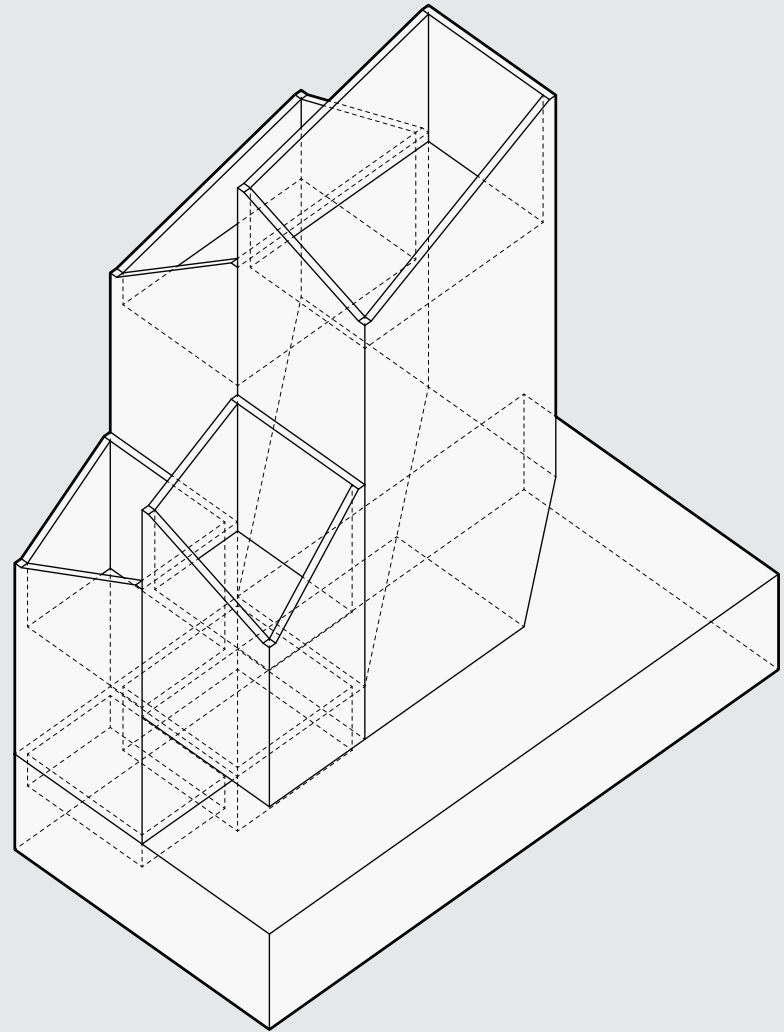
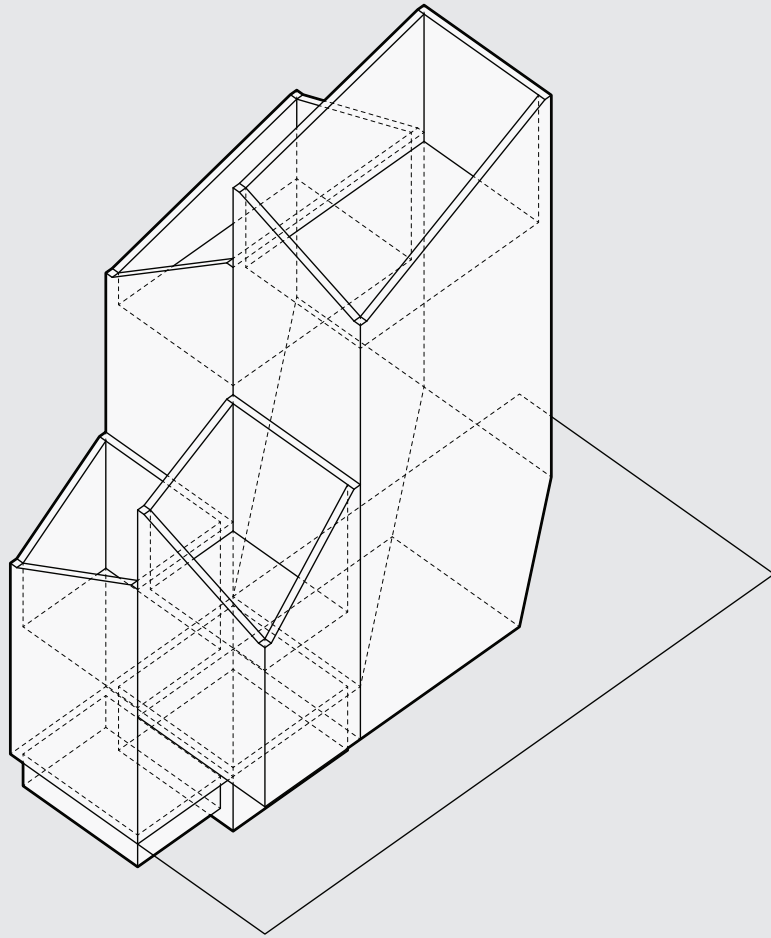

CREATE CONTROL POLYGON

FINAL GEOMETRY

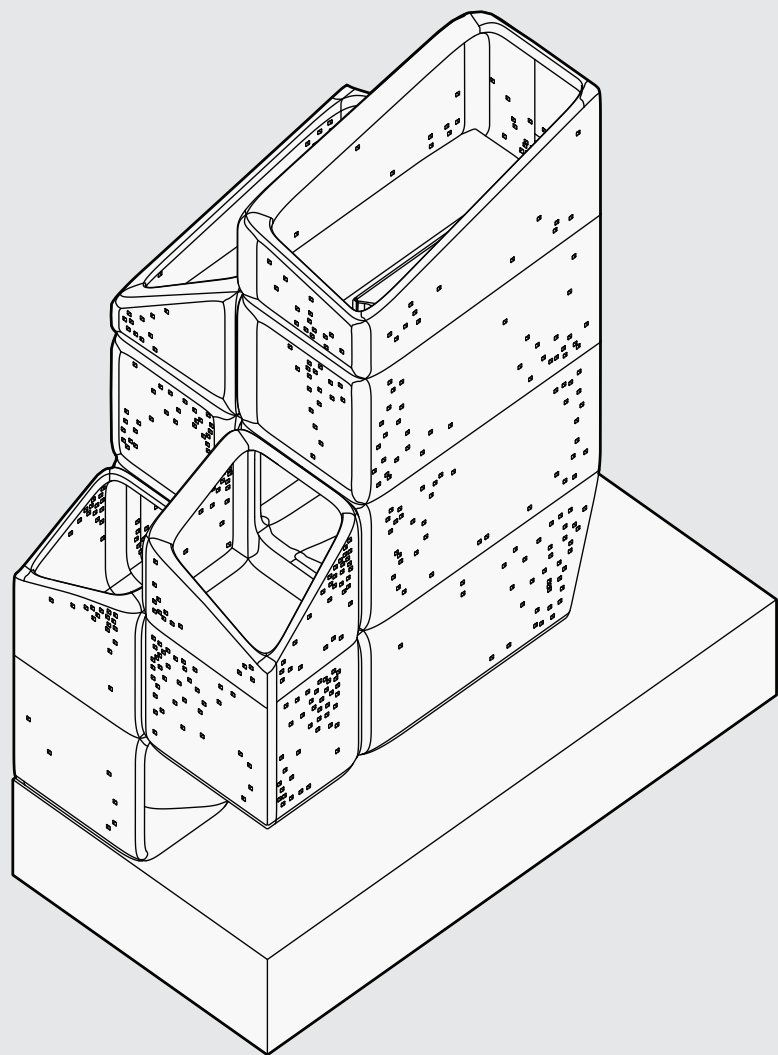
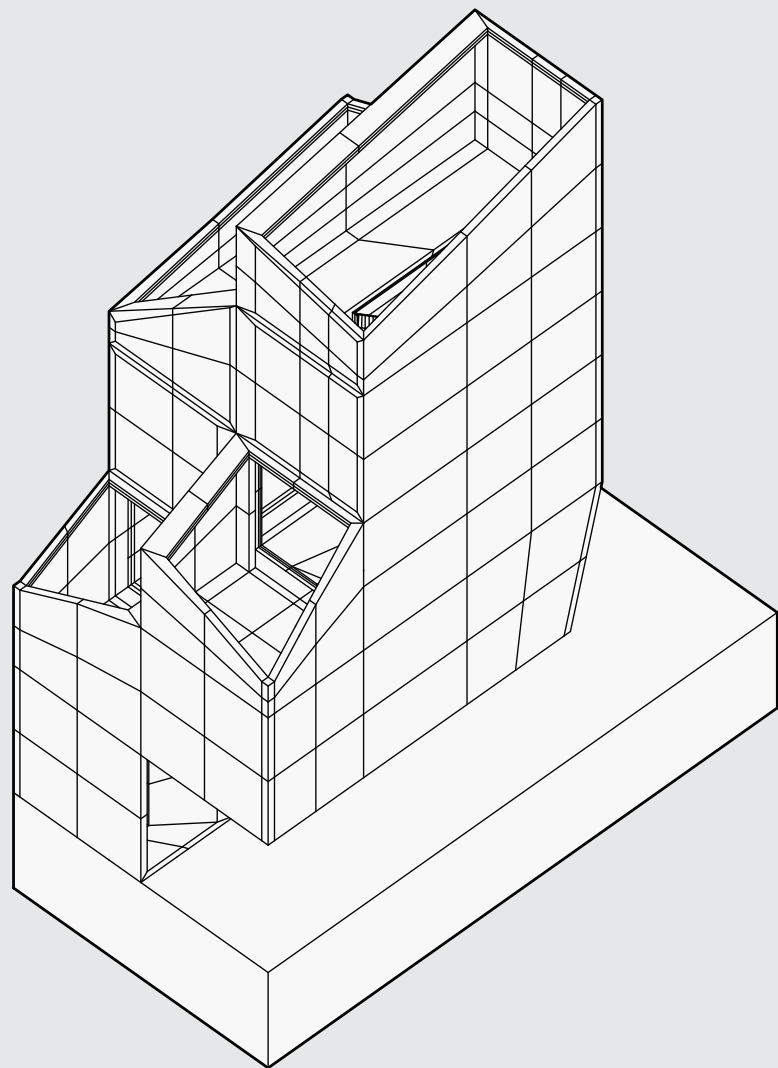





RAPID ASSEMBLY

One of the most important driving forces behind the case study house, has been the assembly sequence on site. For it to be assembled in no longer than a day, the case study house must be composed of the fewest number of parts possible and come together in a simple, unobscured way. To accomplish these goals of rapid construction, the dwelling was conceived as a series of plugs and sockets, which could be molded into the tubes. This composition would allow for them to be simply plugged in to one another on site.

The assembly sequence would begin by embedding a prefabricated foundation into the ground. Next, the primary tubes would plug together, be tilted up and then plugged into the foundation. Mechanical fasteners have been replaced with adhesives which are capable of transferring the loads uniformly across the skin. The secondary tubes would then be tilted up, plugged into the primary tubes, and adhered and strapped together until set.

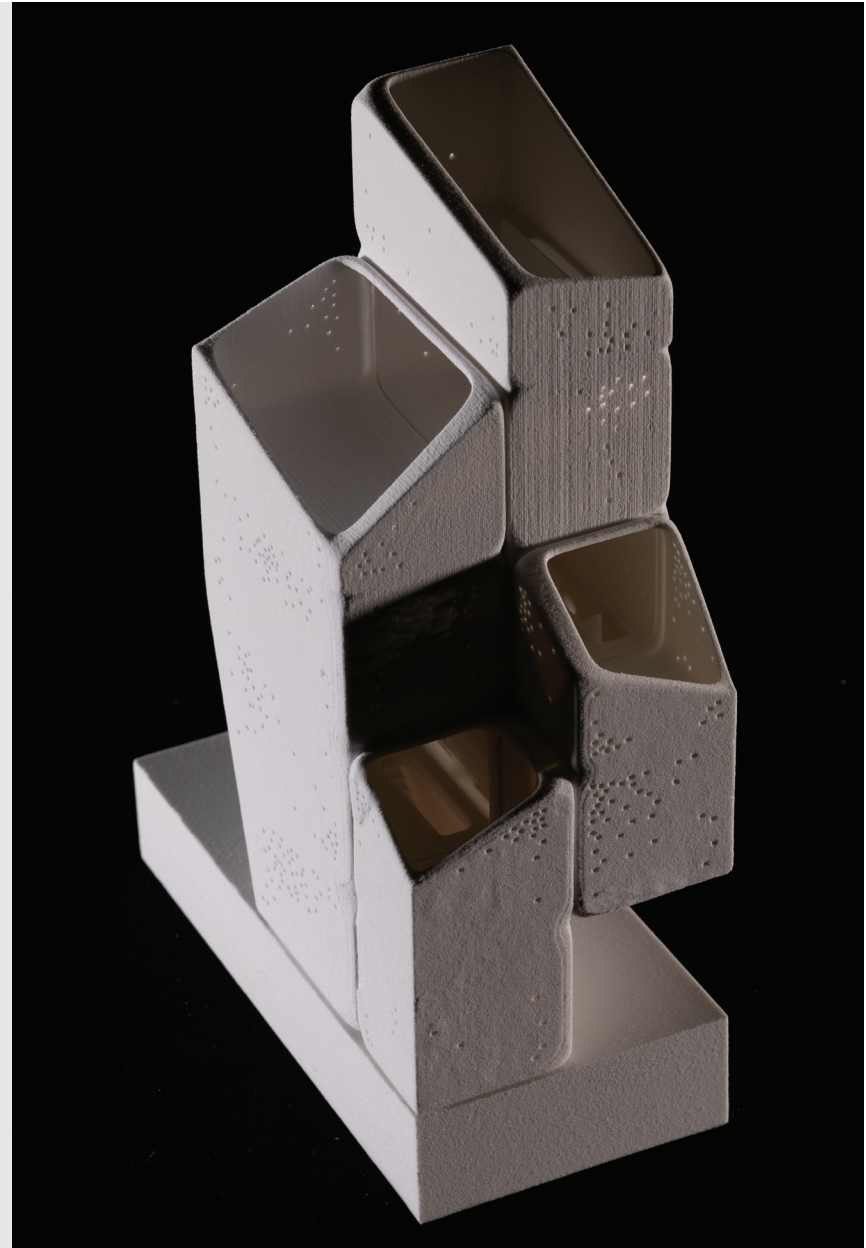

INDIVIDUAL CAPSULES

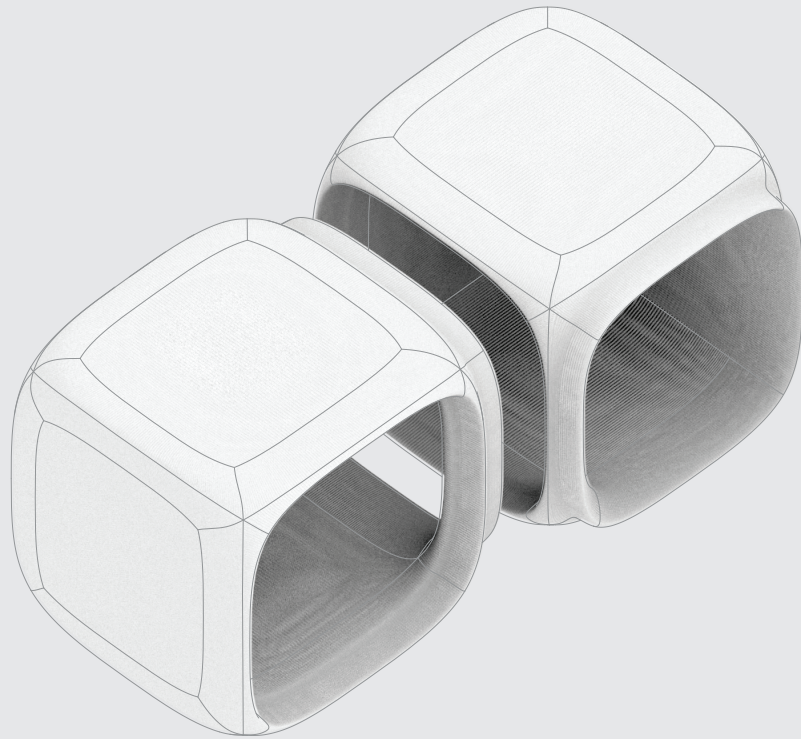

CROSS SECTION PLANE

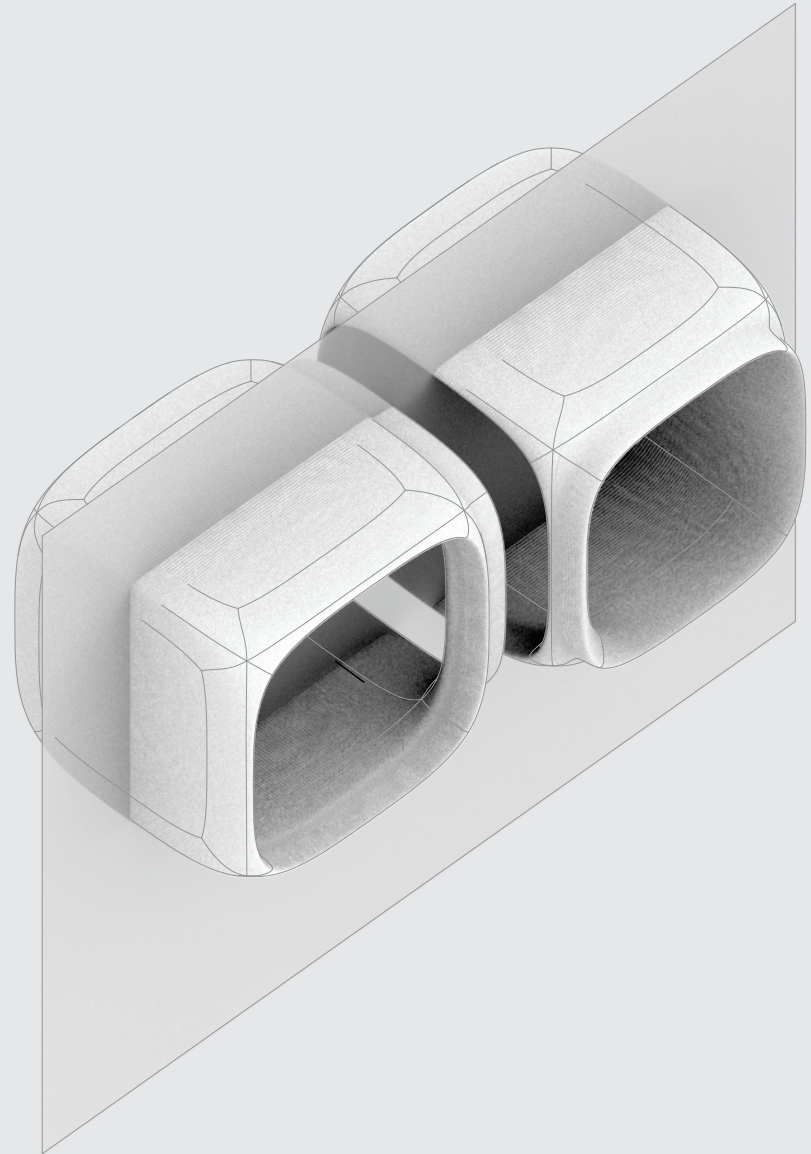

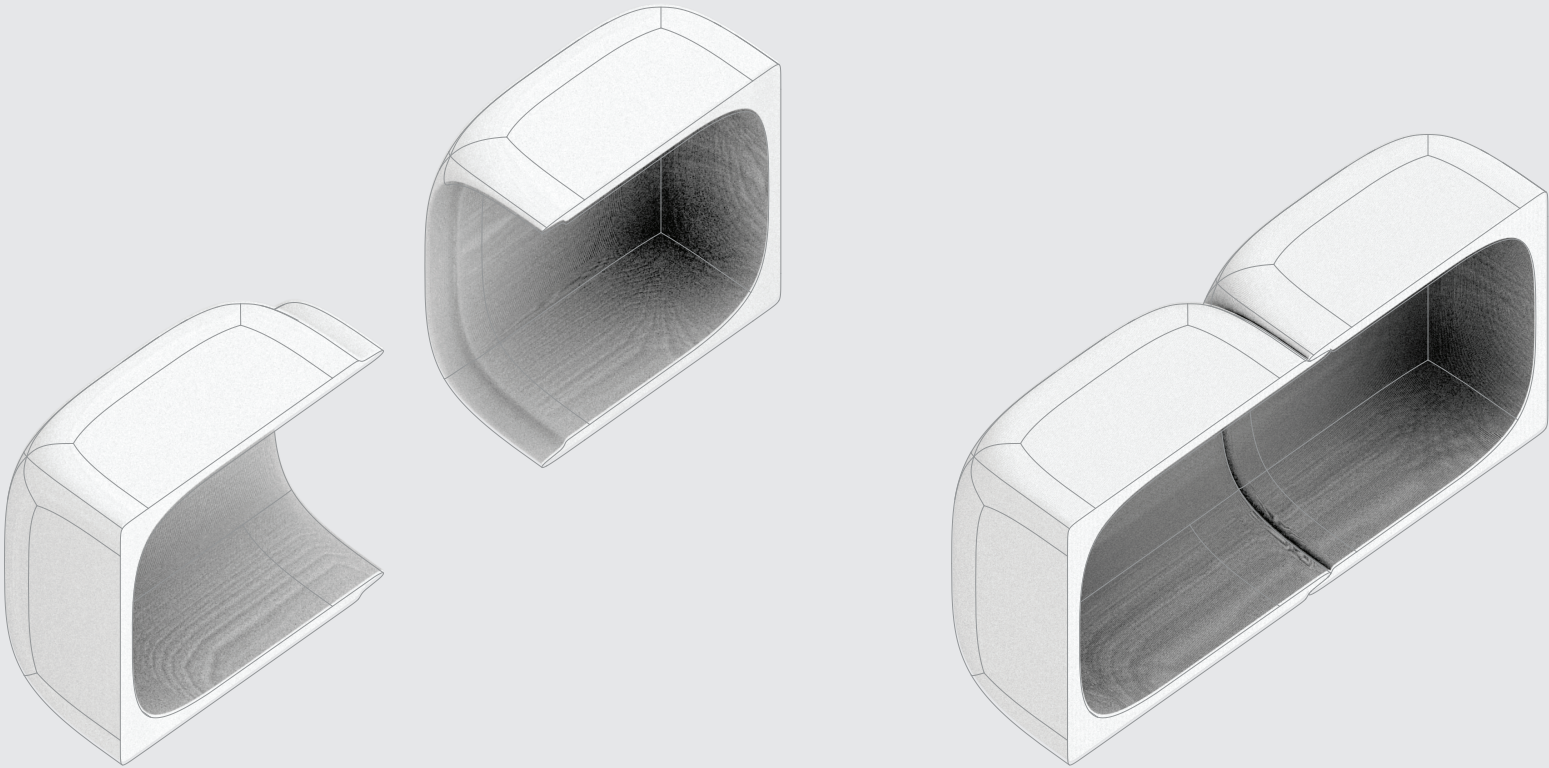



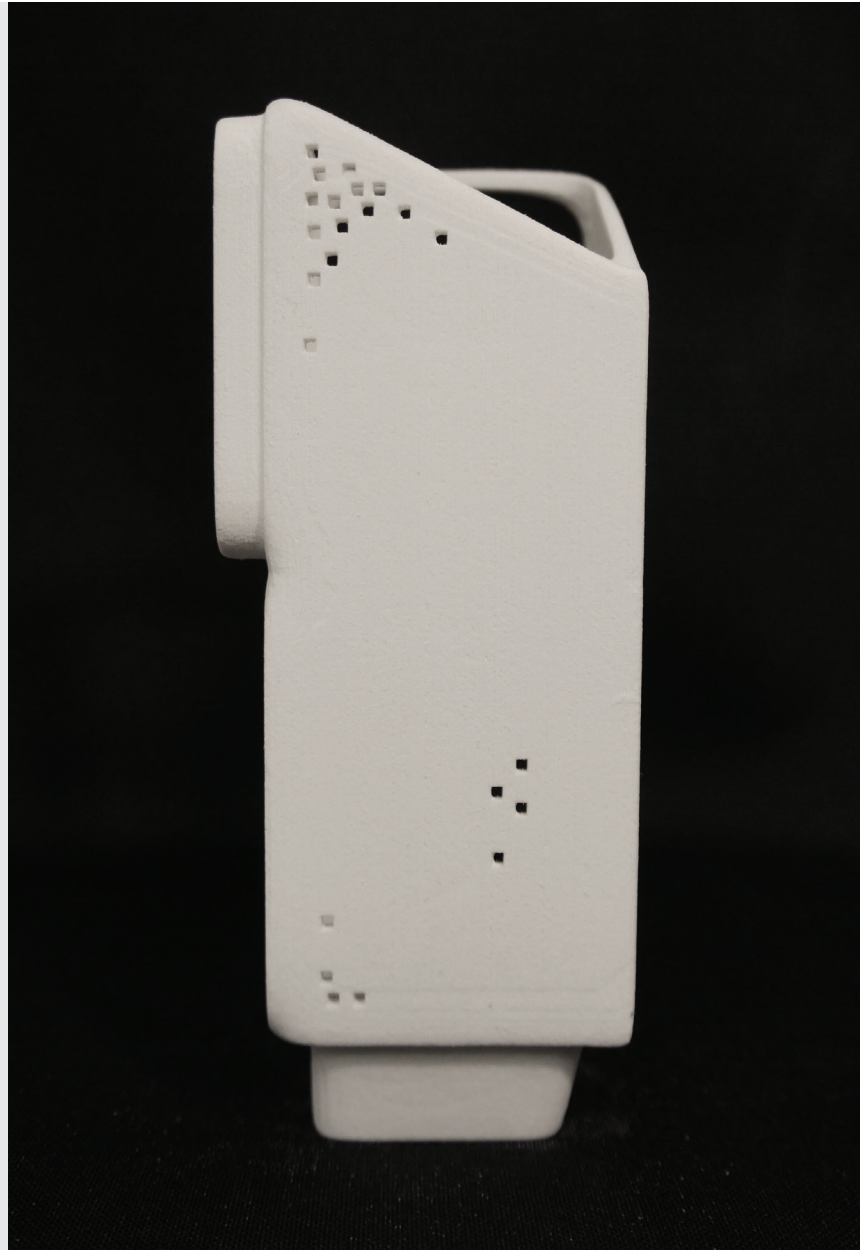

PRIMARY TOWER 1

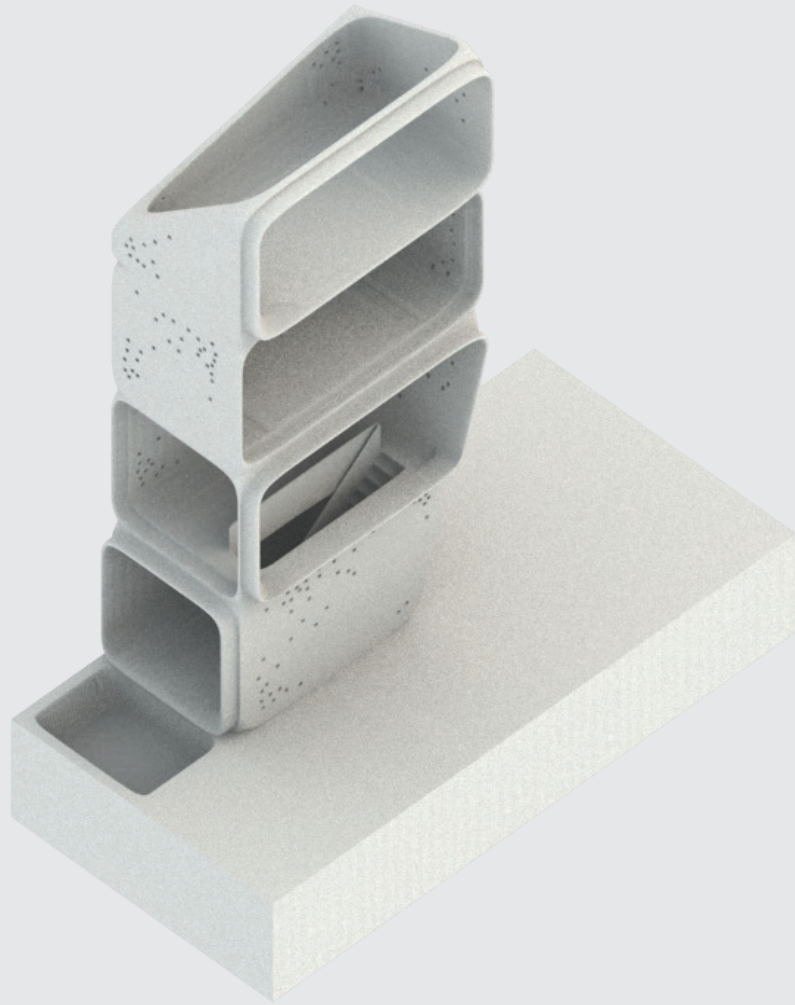

PRIMARY TOWER 2

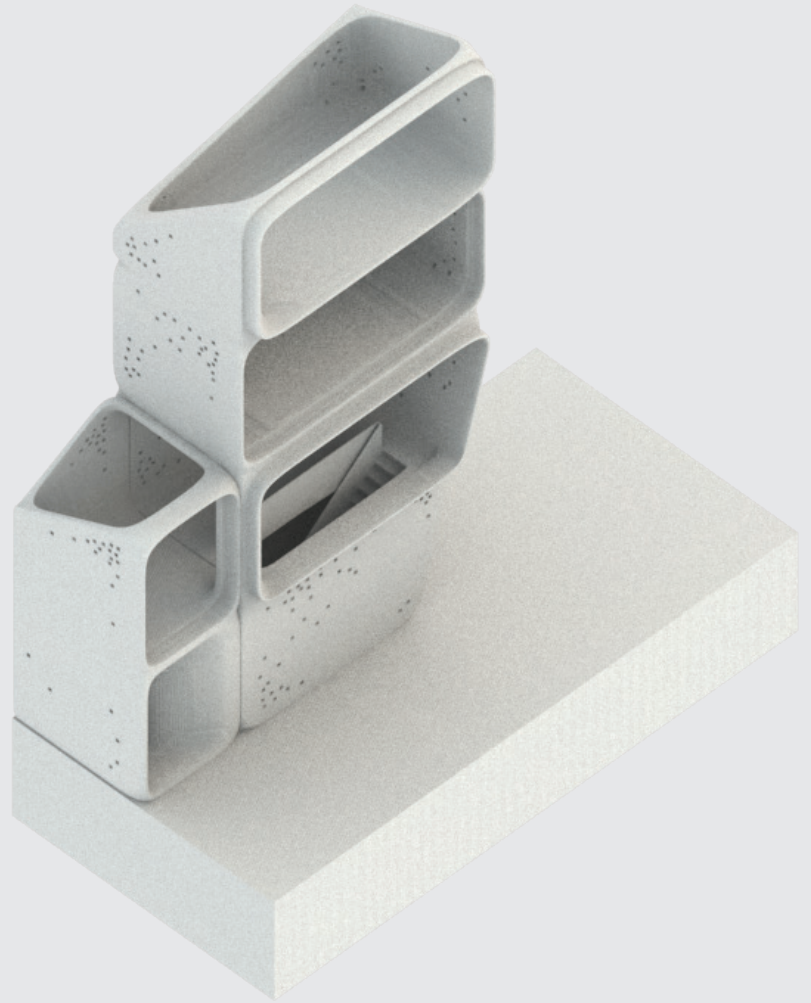

SEOCNDARY TOWER 1

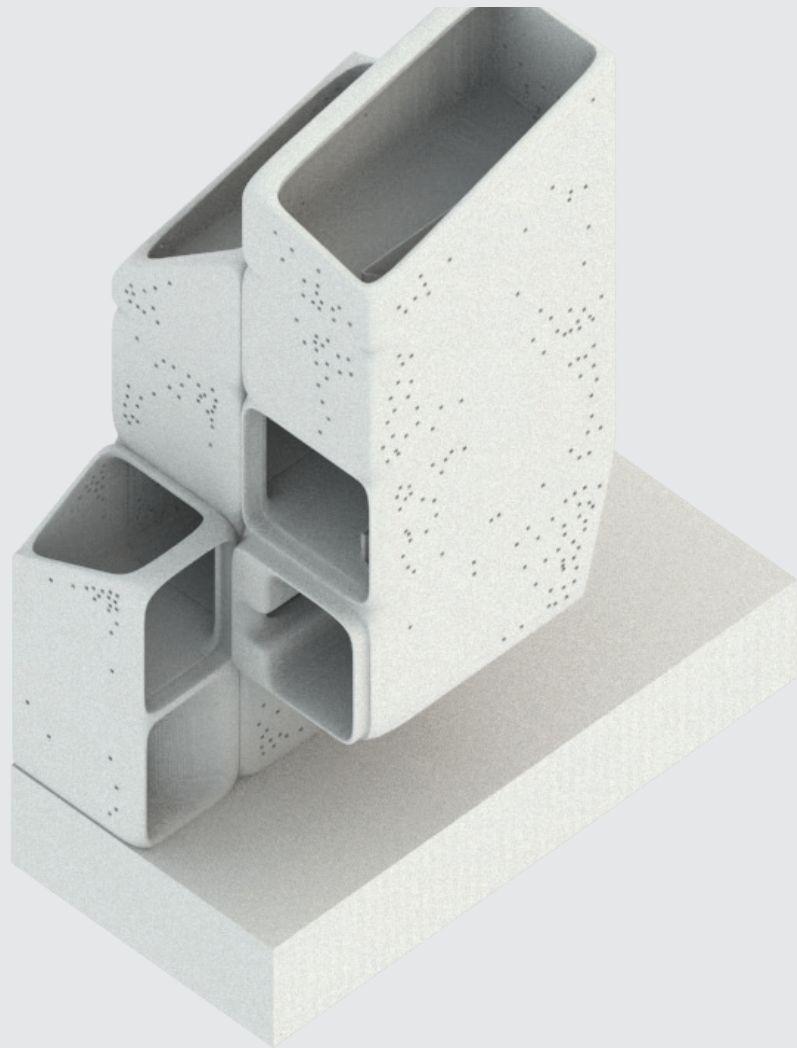

SEOCNDARY TOWER 2

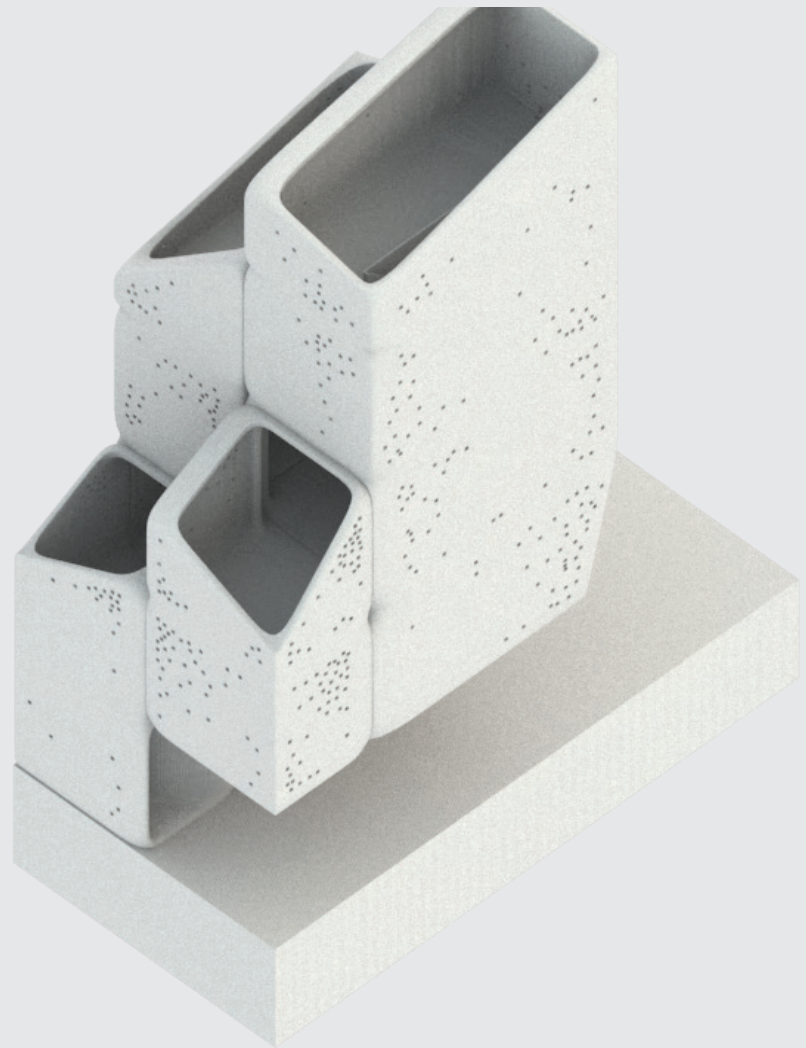

TYPICAL KISS-OFF WALL PANEL

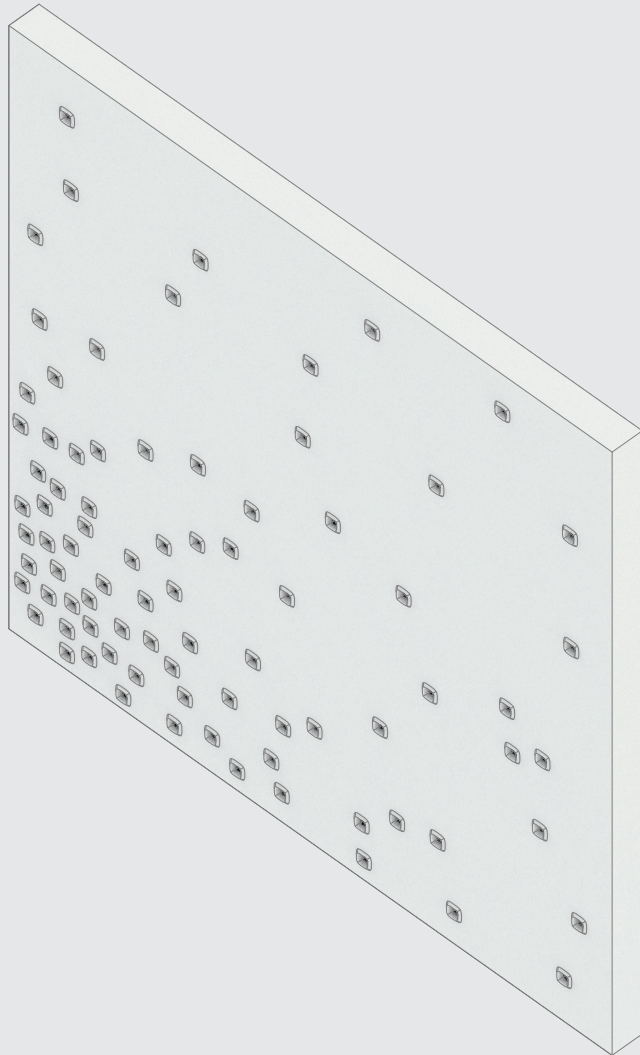

TYPICAL KISS-OFF MODULE

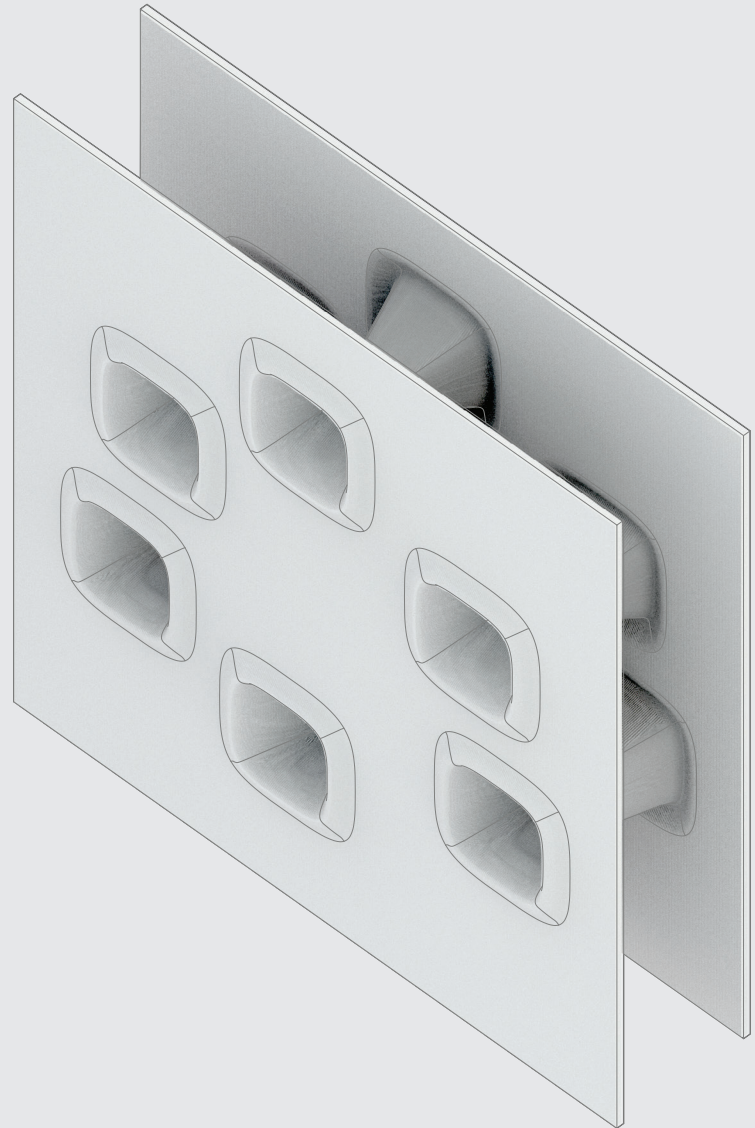

STRESSED SKIN

The structure is composed of an interior and exterior load bearing skin. The interior and exterior skin are tied back using kiss-offs, a technique commonly used when creating lightweight hollow plastic parts. The interior and exterior skins are connected by an inner foam core across which loads are transferred. When the stress in the skin is above a certain range, the kiss-off serves to create a more rigid, structural connection between the two surfaces. Through mapping the stress in the skin, a clear relationship can be developed between the max stress levels and the placement of kiss-offs. A pattern emerges as the density of kiss-offs increase in relation to higher stress levels in the skin. The exterior of the dwelling reflects the gradient of structural loads and load transfer throughout the skin. Sometimes the two surfaces meet in the middle just barely touching off; while in other conditions, the two surfaces will intersect cutting through and creating an opening.

TYPICAL KISS-OFF UNITS

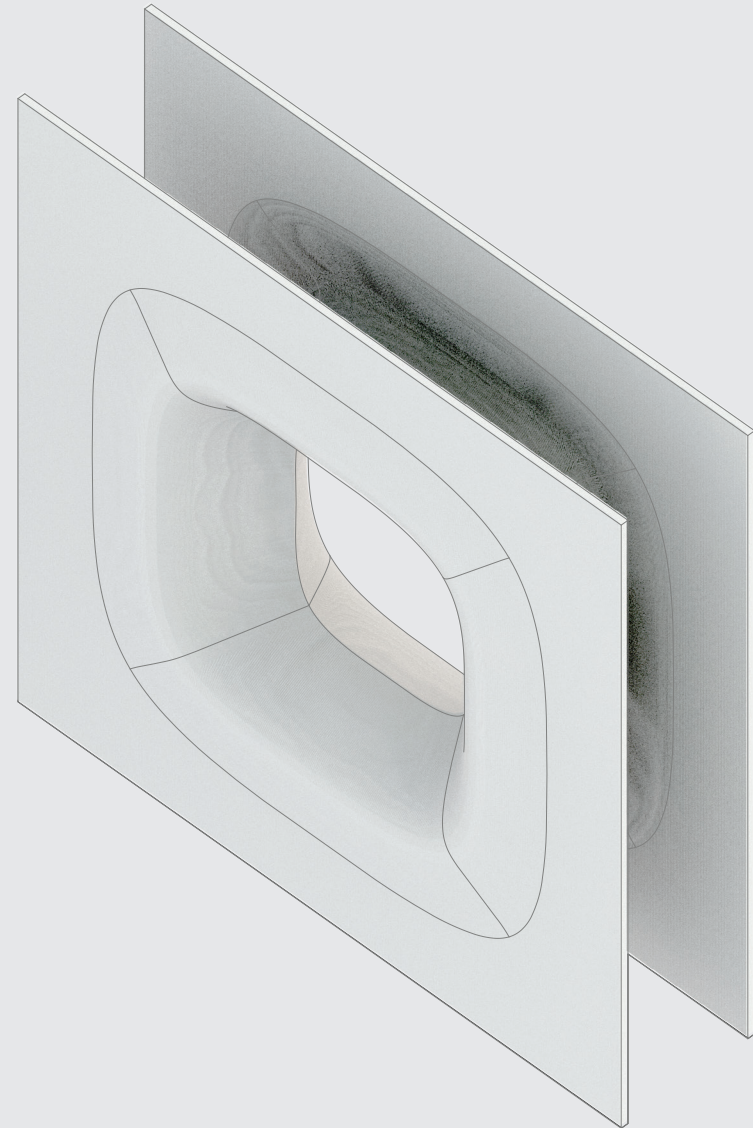

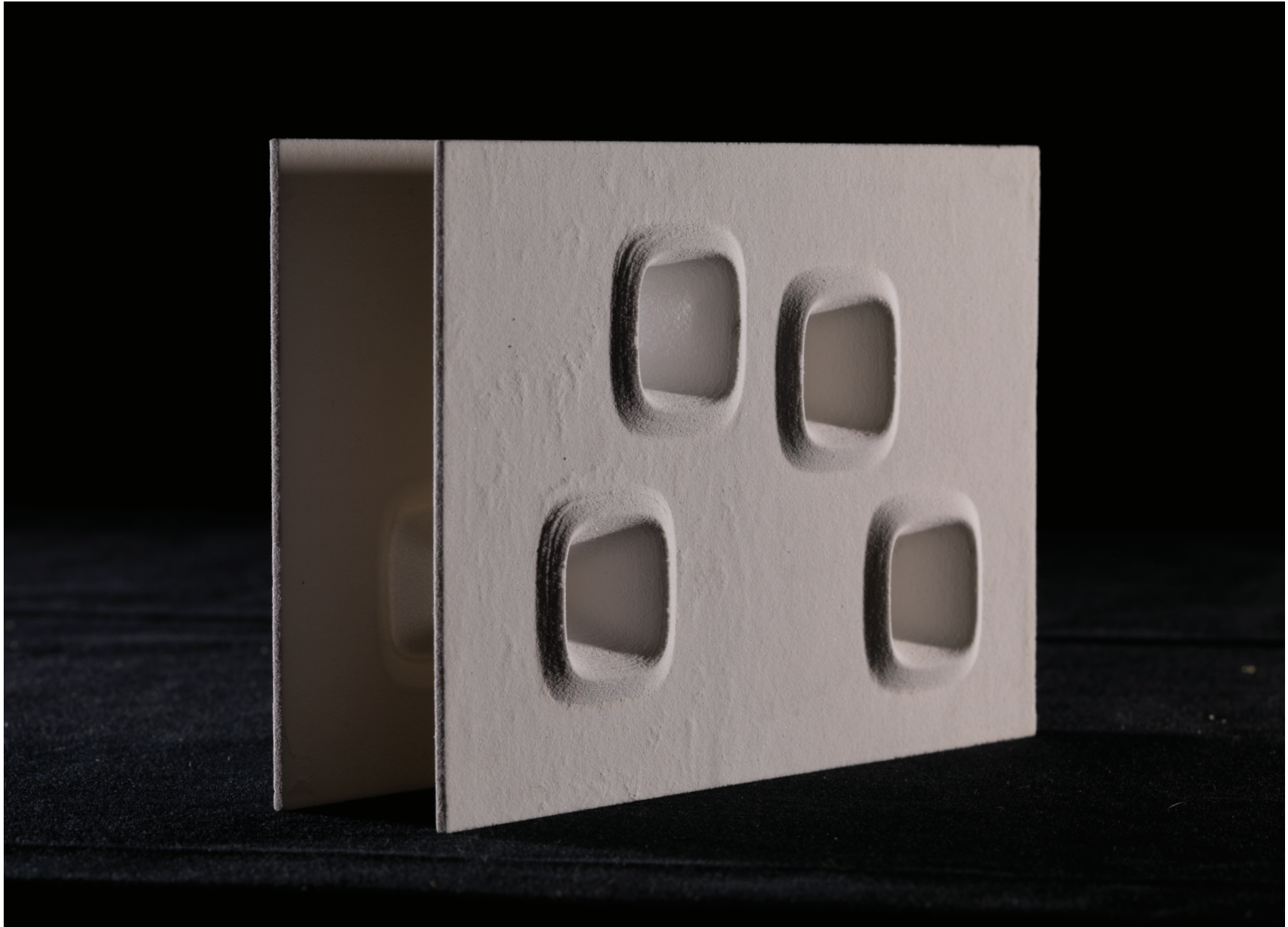

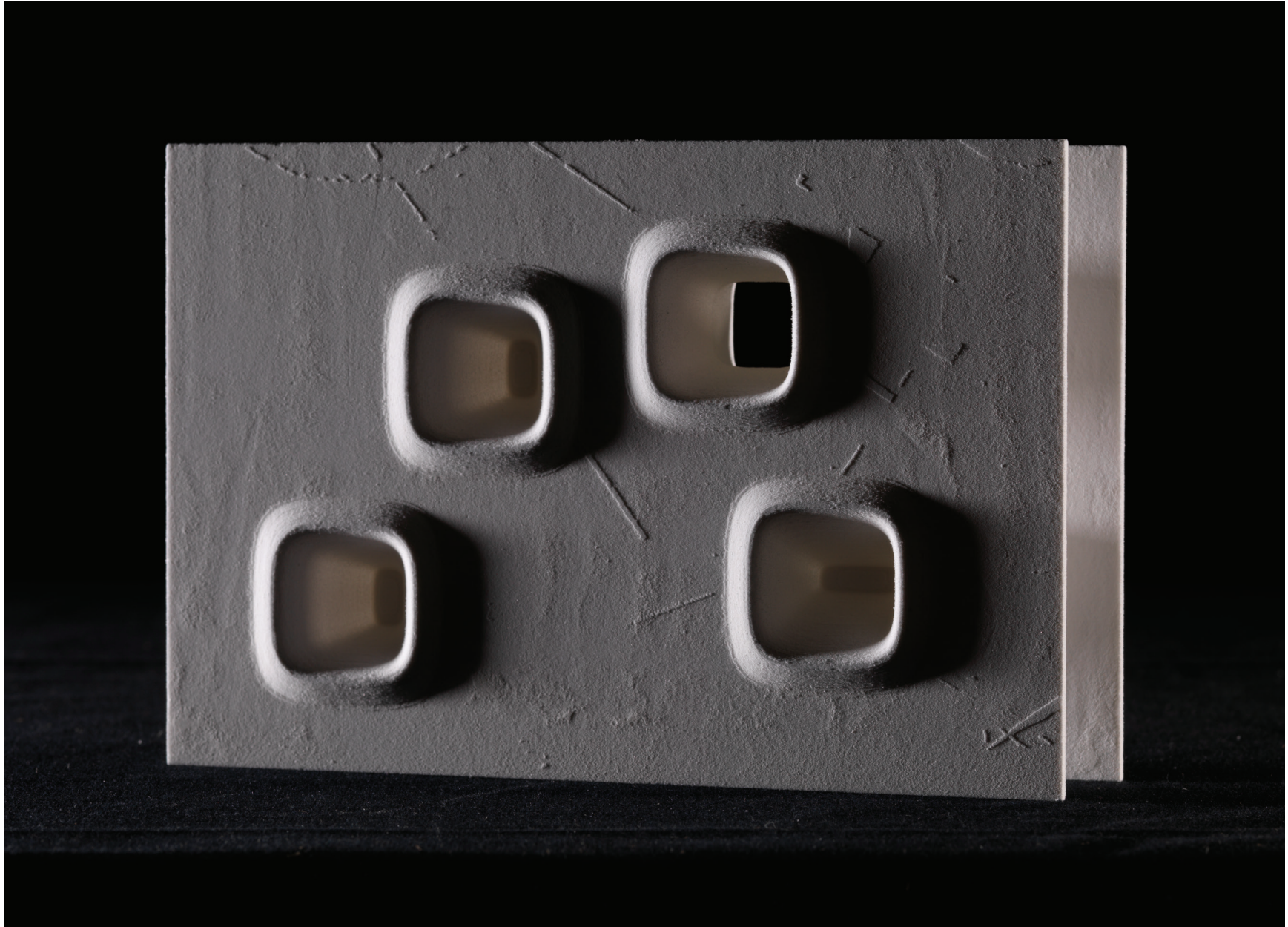

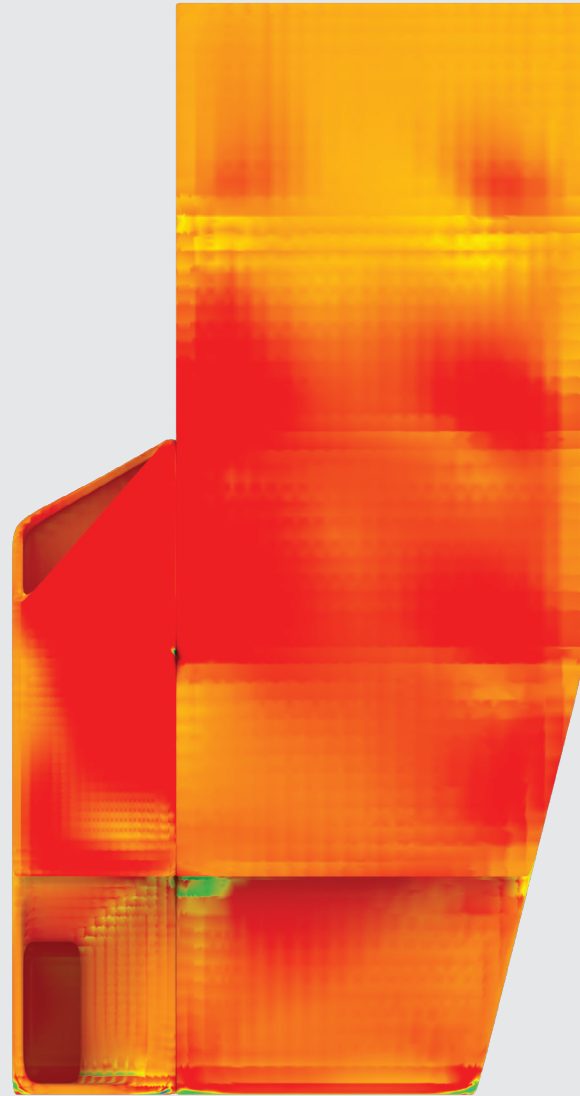
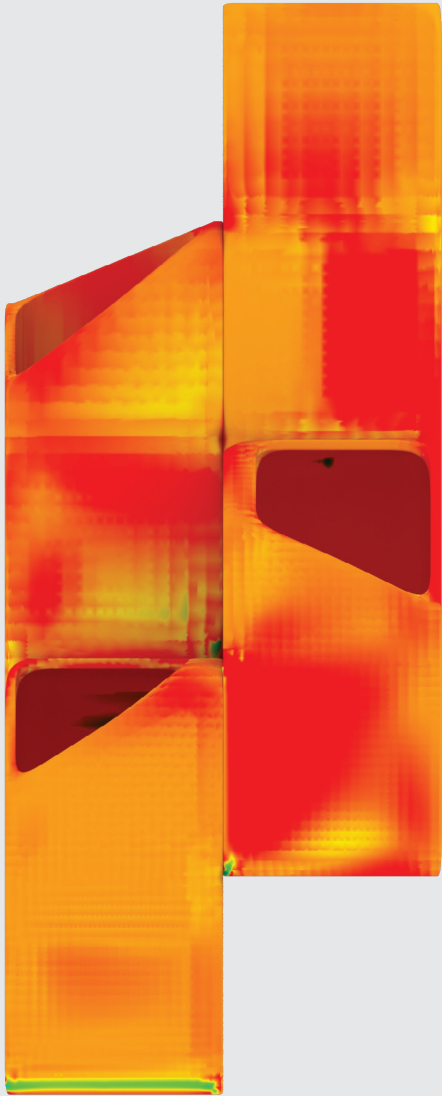

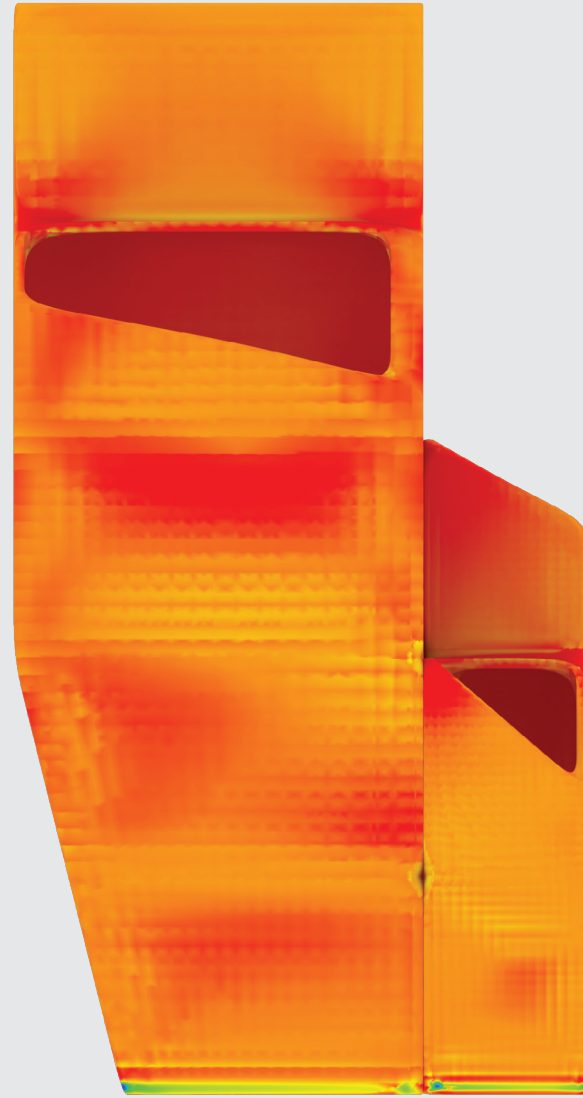
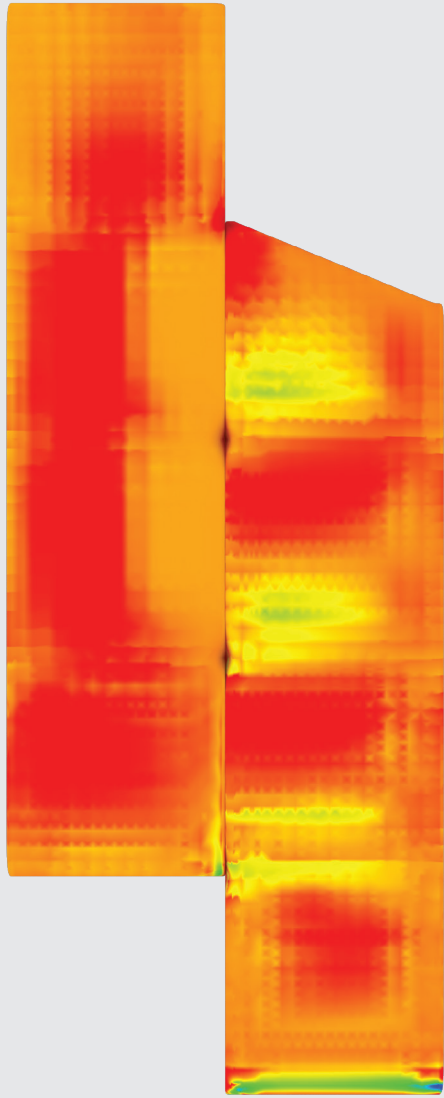

SECTION

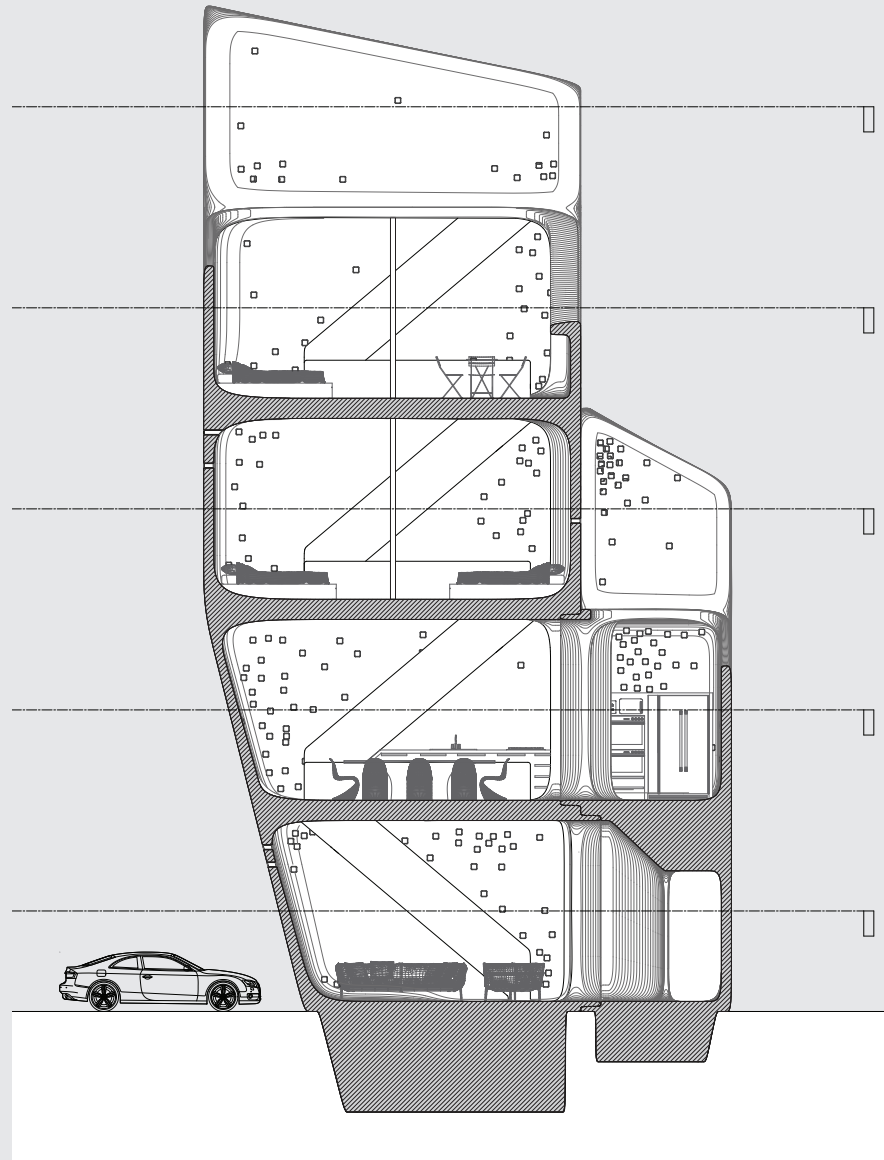

DWELLING

After parking, you enter the dwelling from a shaded forecourt where the building funnels you inside. Directly upon entering the dwelling you are presented with the option of entering the living room, or going up the staircase. The living room is the most public space in the house and primarily serves the guests of the family. As one ascends up the stairs and reaches the second level of the house, they are presented with a choice to go left or right. To the left is the dining area which welcomes guests and family alike, and to the right is the more private kitchen. Across from the stairs is a light well/courtyard that is accessible through both the dining and kitchen spaces, which allows for the possibility to open up and reconnect these two spaces.

Before entering the more private kitchen zone, a staircase leads up to the third floor. In the gradient from most public to most private, the third floor falls in the middle. The children's bedrooms are strictly family spaces; there are two bedrooms each with two beds, and potential space for up to four children. The bedrooms share a common bathroom as well as a light well/courtyard.

Moving up the now stacked staircases, the most private room in the house is the parents room, on the fourth floor, with its own bathroom, seating area, fifth level roof access, and a light well/courtyard. All of the spaces in the house are conceived with the idea of a relationship to an open courtyard. The light well/courtyard assists with bringing light into the space, while also maximizing privacy.

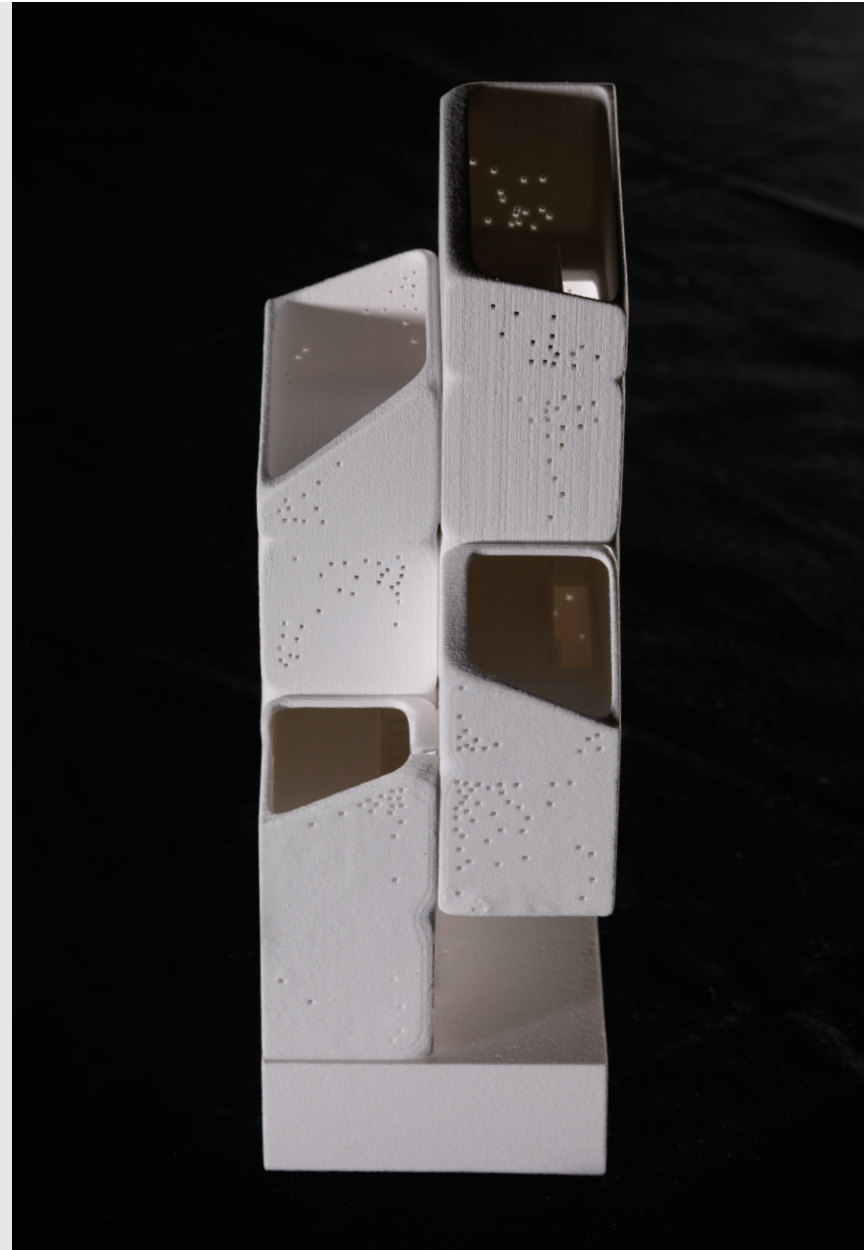

FIRST FLOOR PLAN

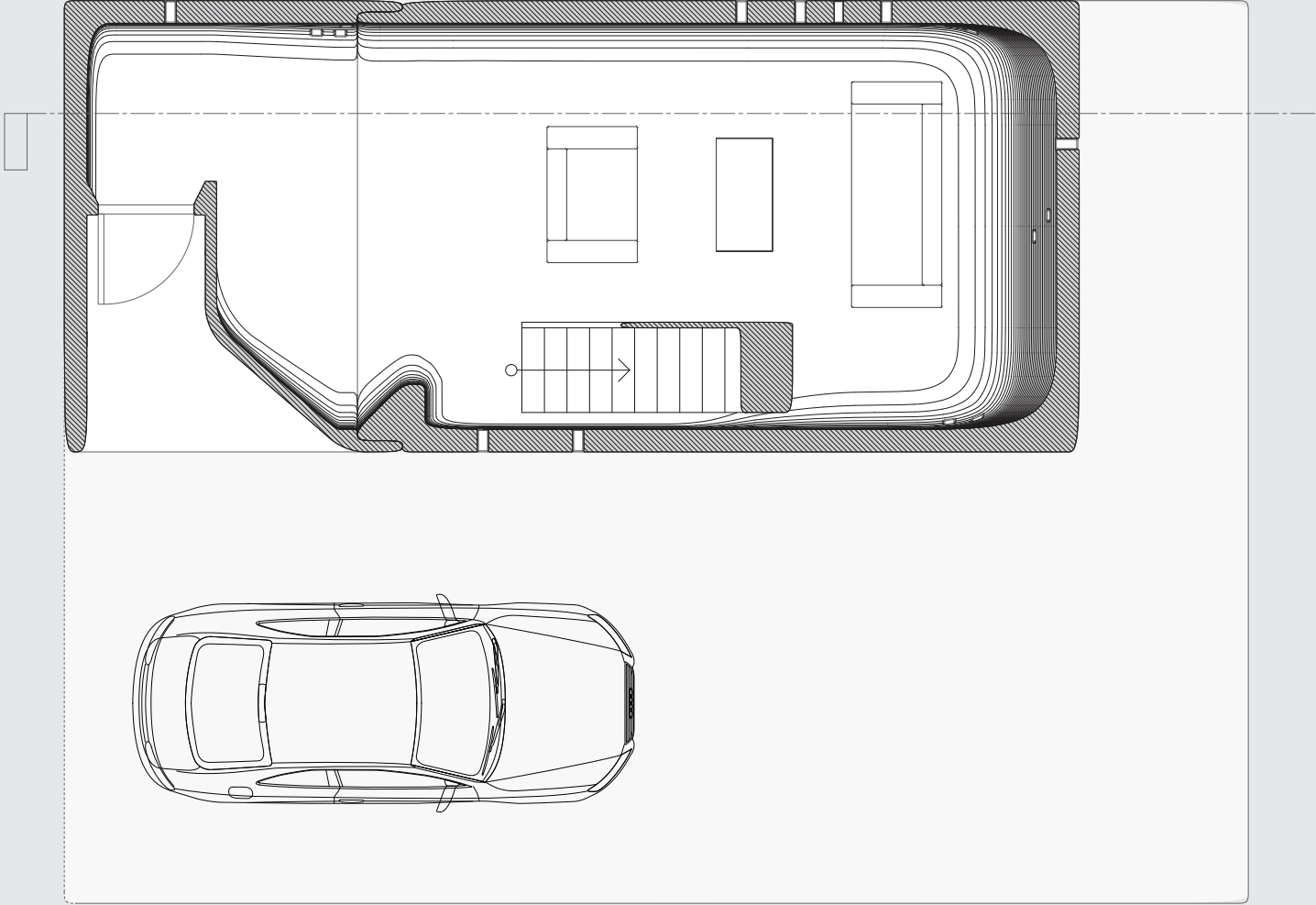



SECOND FLOOR PLAN

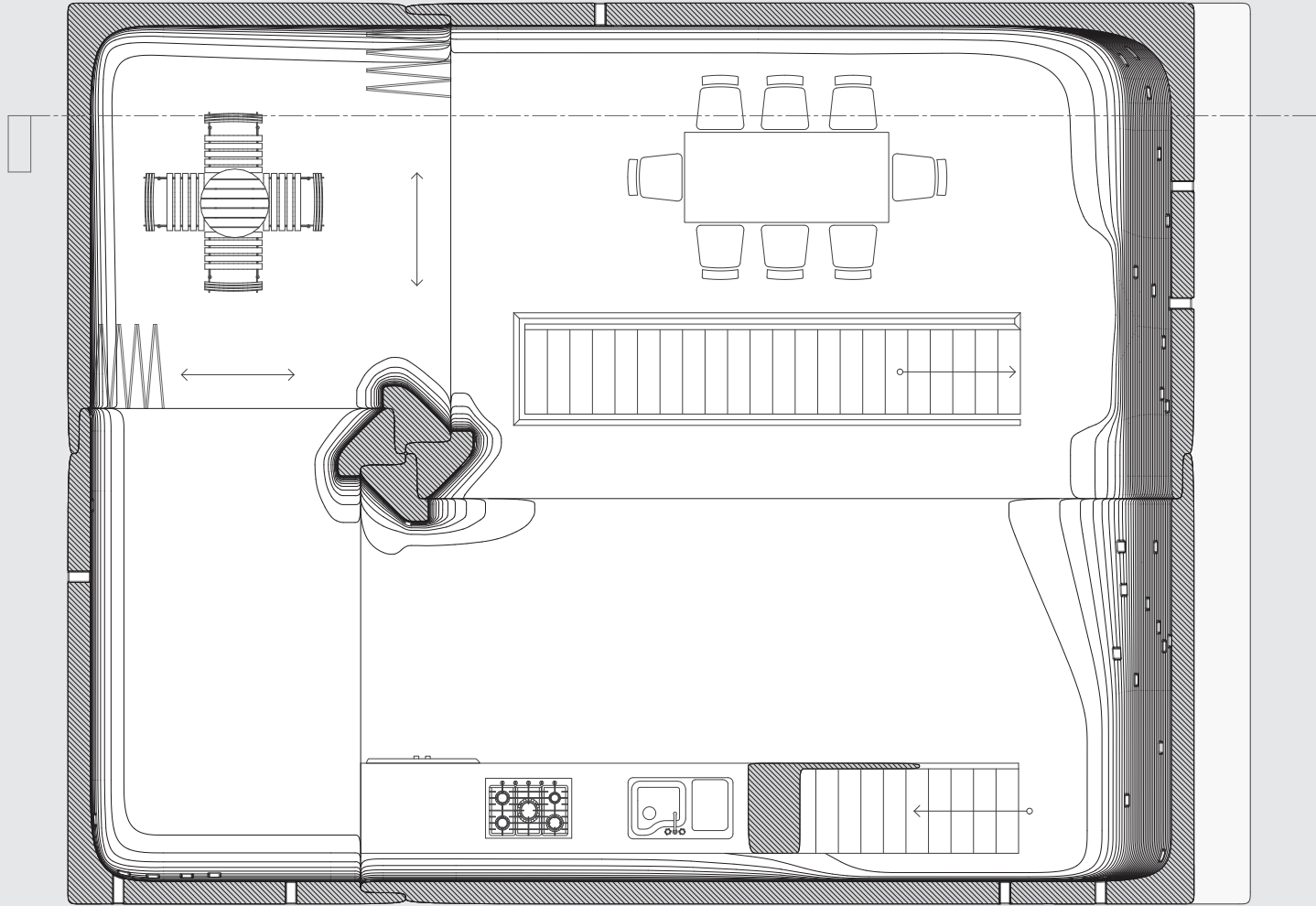

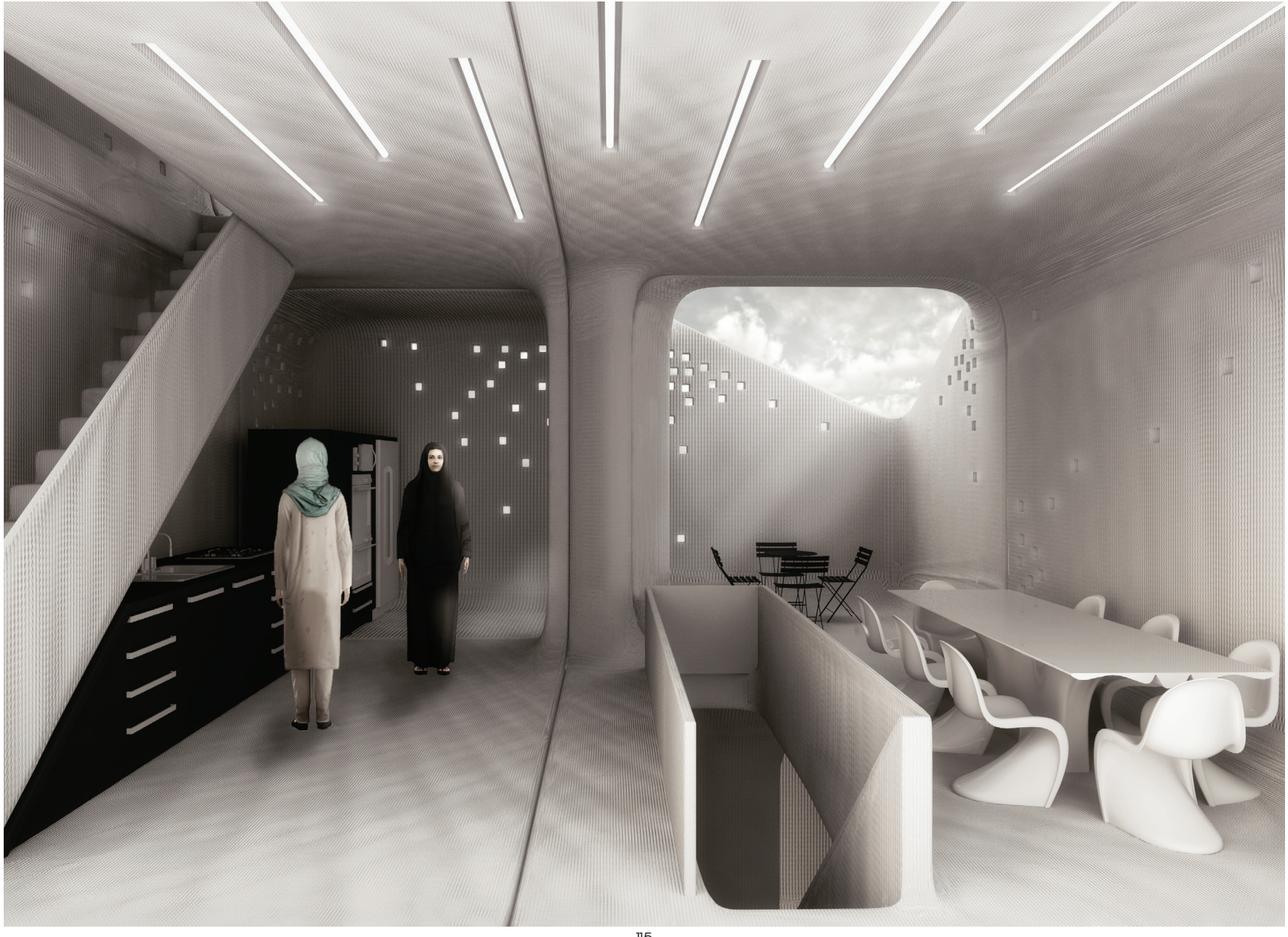

THRID FLOOR PLAN

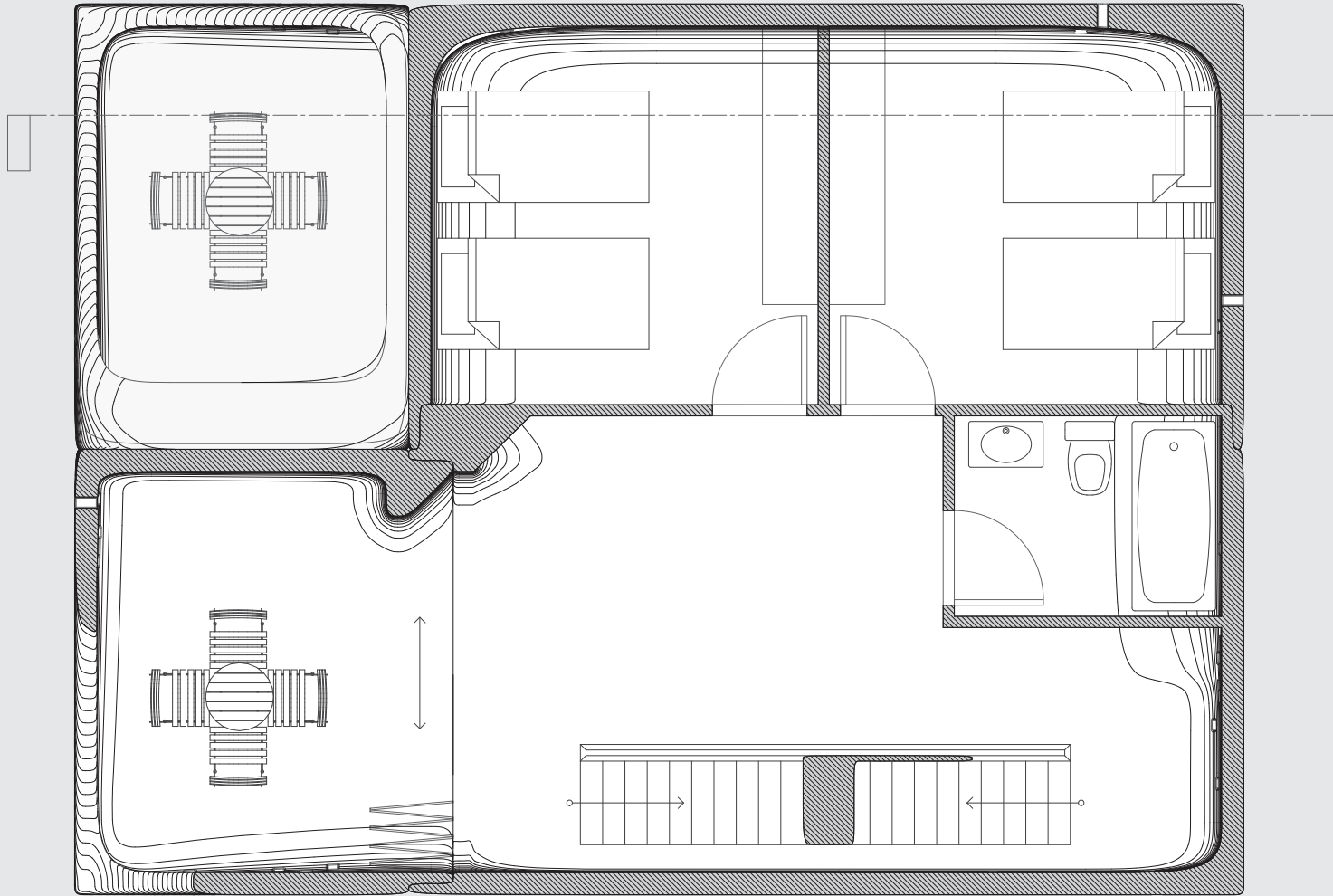

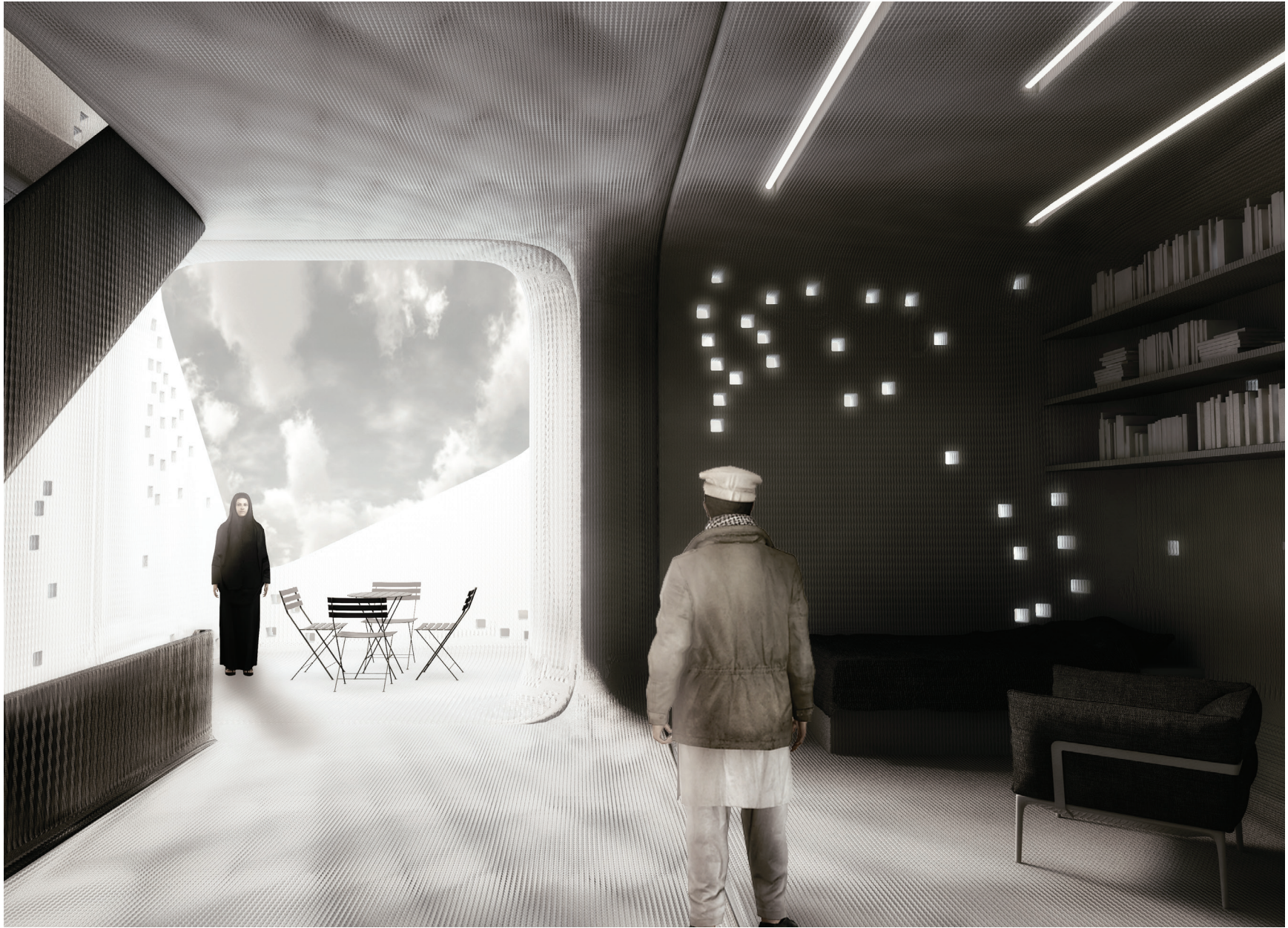

FOURTH FLOOR PLAN

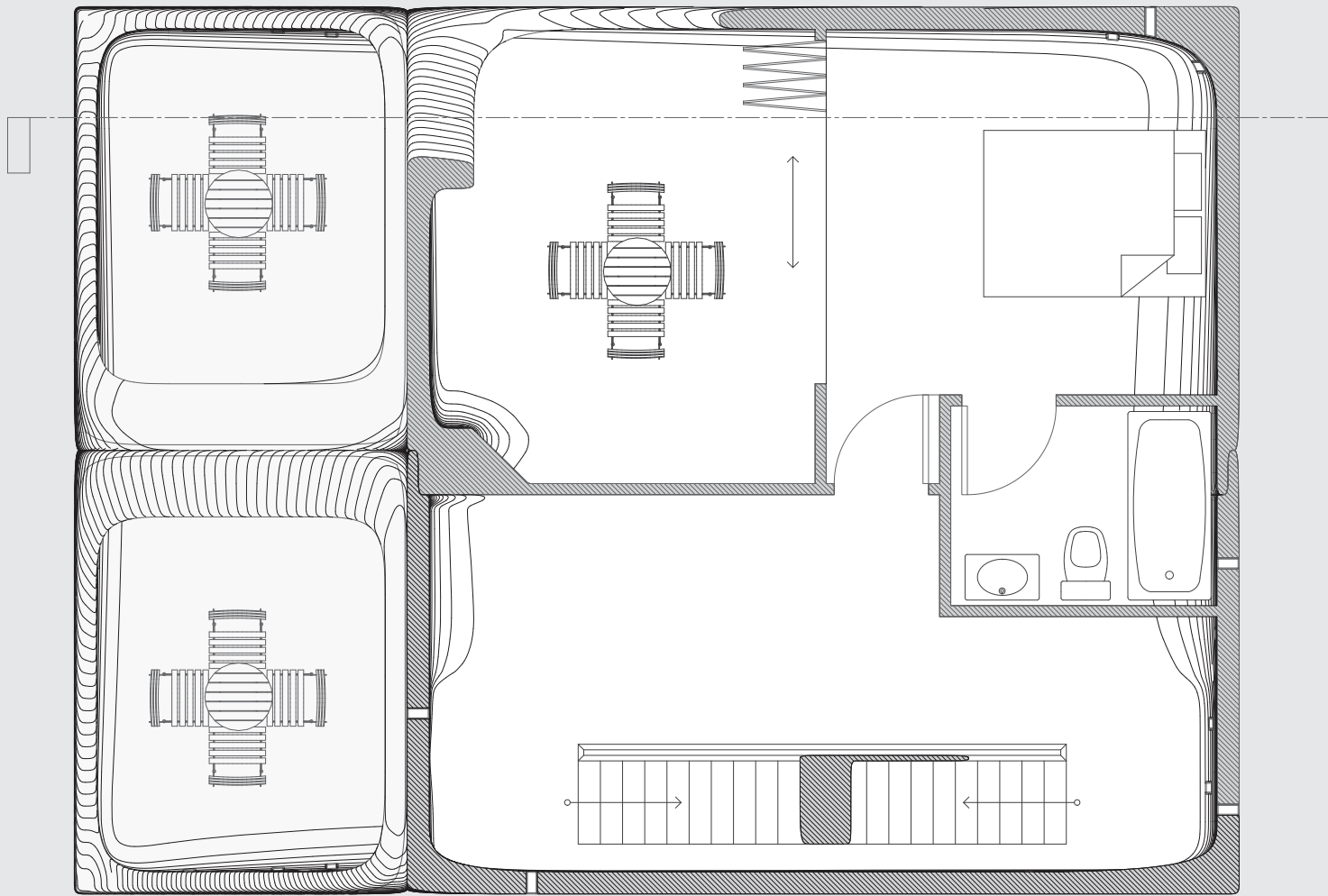





CONCLUSION

As Iraq struggles to come to terms with a housing crisis that has plagued the country since before the 2003 American invasion and concluding war, the country's immense oil reserves hold the key to restoring balance. By utilizing associated gas, the by-product of extracting crude oil, as plastic, Iraq can domestically produce and construct 100% petroleum based homes, and eradicate the displacement of 2.3 million Iraqis.

With Royal Dutch Shell already committed to capturing around "700 million cubic feet of associated gas" with the intention of also "utilis[ing] the gas surplus"¹ and the aforementioned housing need, it is a ripe time to reconsider the importance of the "Monsanto House of the Future" and explore the potentials of composites within architecture.

By using plastics as a building material, many new potentials come into play including a long life span, possibly one hundred years or more; an extreme strength to weight ratio that allows for prefabrication of a number of intelligent parts that can be easily transported and rapidly assembled on site. Plastics also allow for an increased capacity to facilitate a much taller dwelling, radically reducing the required land needed to construct a home.

Plastics coupled with Iraq's unique form of domesticity as well as cultural and religious factors shape a new type of dwelling. Made up of four petro based tubes, each mold-

ed with plugs and sockets that incorporate quick intelligent assembly, capped with shaded courtyards that double as light wells, serve to blur the boundaries between interior and exterior effectively doubling the livable space. The dwelling presents an alternative way to conceive of the reconstruction needed to rebuild the country. Utilizing what is in its own soil, Iraq can allow millions of Iraqis to finally return home to their families, communities, and lives.

¹ Unknown. Shell Plans Venture to Expand Presence in Iraq. The National. 2011. Web. 2012



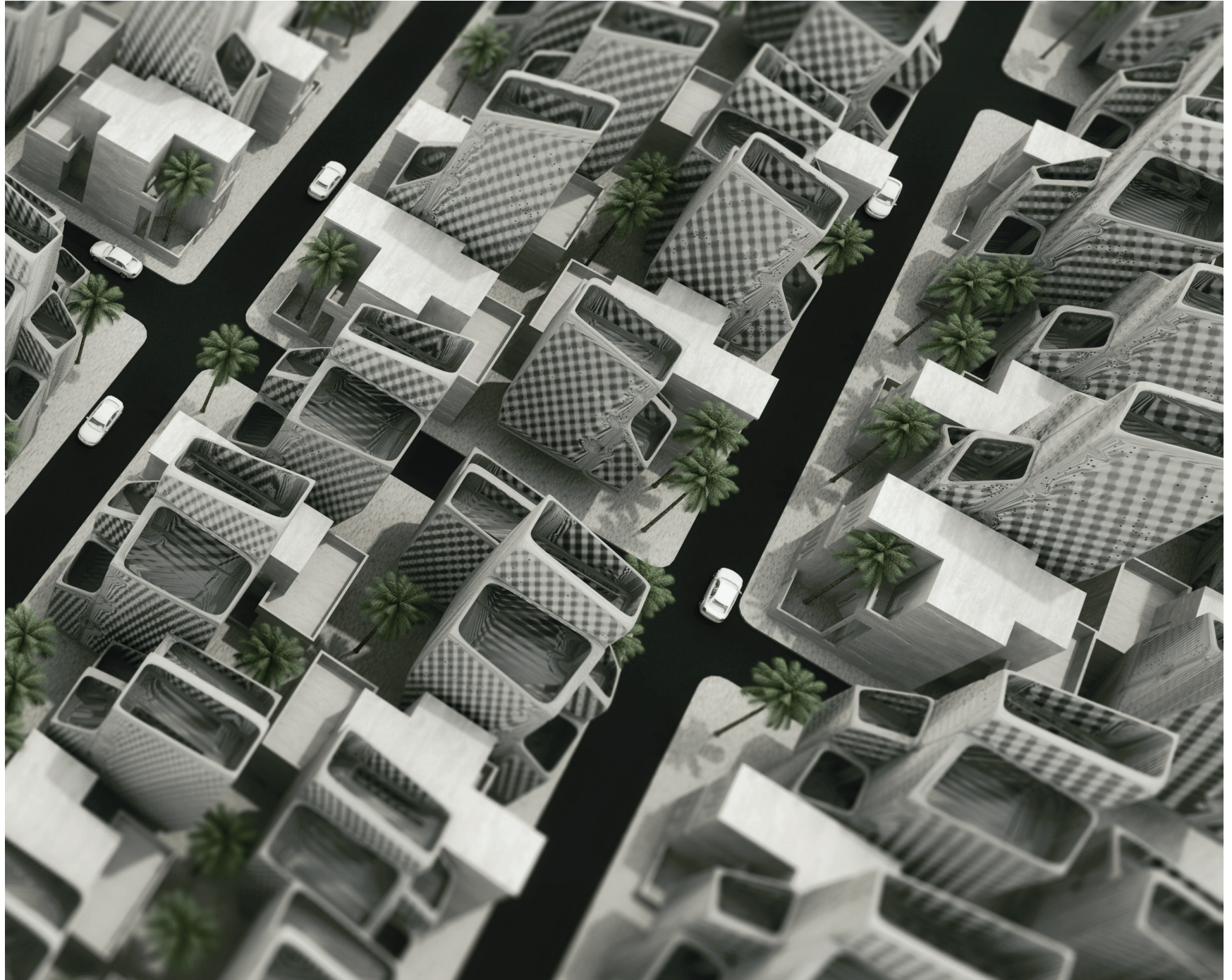

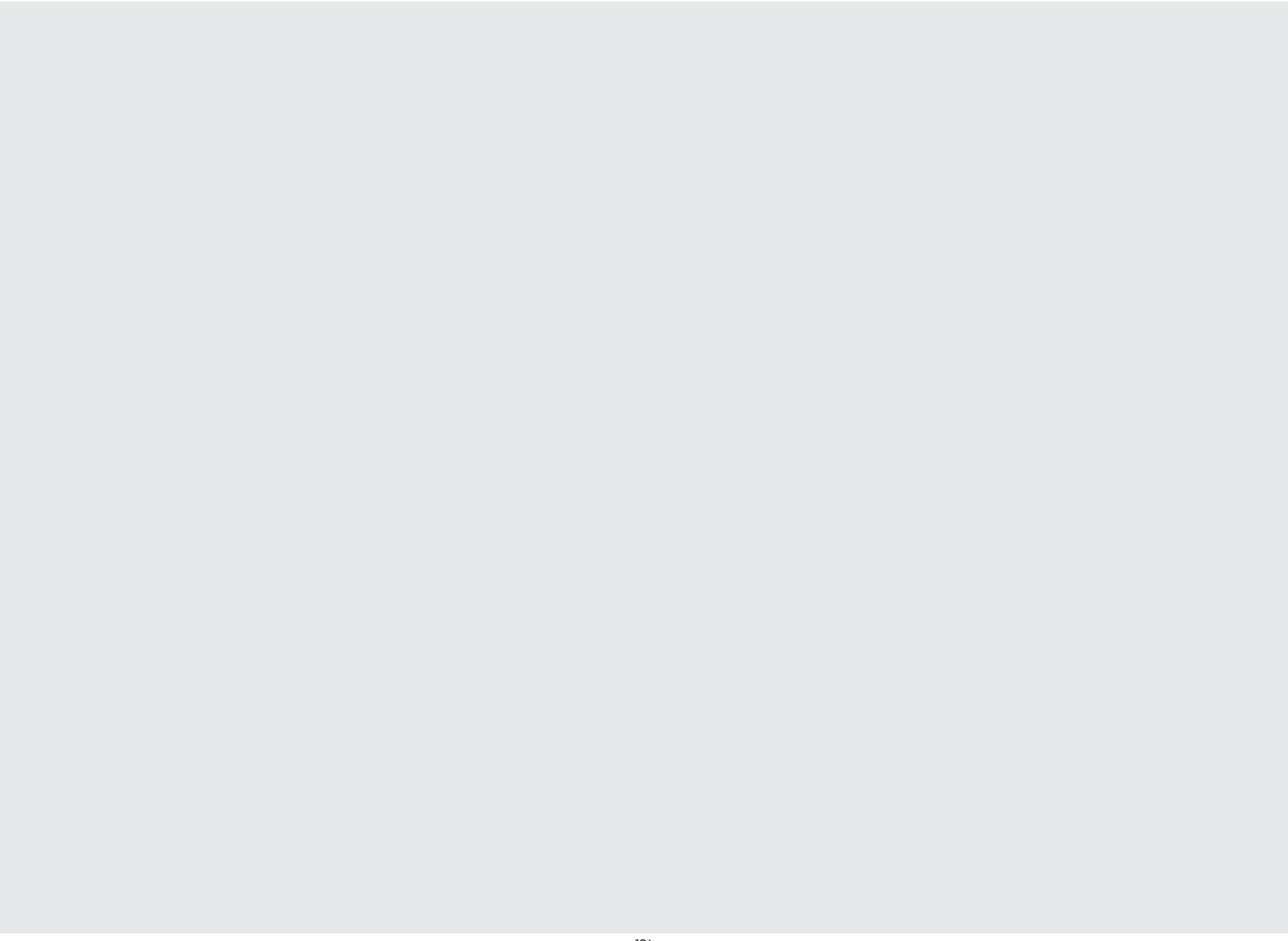

O5 // BIBLIOGRAPHY

Branko, Kolarevic. *Manufacturing Material Effects : rethinking design and making in architecture*. New York: Routledge, 2008.

Branko, Kolarevic. *Architecture in the digital age : design and manufacturing*. New York: Taylor & Francis, 2005.

Lynn, Greg & Mark Foster Gage. *Composites, surfaces, and software : high performance architecture*. New Haven, Conn. New York: Yale School of Architecture Distributed by W.W. Norton & Co, 2010.

Meredith, Michael. *From Control to Design : Parametric/Algorithmic Architecture*. Barcelona New York: Actar, 2008.

Brownell, Blaine. *Material strategies : innovative applications in architecture*. New York: Princeton Architectural Press, 2012.

Bell, Victoria. *Materials for design*. New York: Princeton Architectural Press, 2006.

Oxman, Rivka & Robert Oxman. *The new structuralism : design, engineering and architectural technologies*. Hoboken, N.J. Chichester: Wiley John Wiley distributor, 2010.

Iwamoto, Lisa. *Digital fabrications : architectural and material techniques*. New York: Princeton Architectural Press, 2009.

Farrelly, Lorraine. *Construction and materiality*. Lausanne Worthing: AVA Academia, 2009.

Moussavi, Farshid. *The function of form*. Barcelona New York Cambridge, Mass: Actar Harvard University, Graduate School of Design, 2009.

Brownell, Blaine. *Transmaterial a catalog of materials that redefine our physical environment*. New York: Princeton Architectural Press, 2006.

Brownell, Blaine. *Transmaterial 2 : a catalog of materials that redefine our physical environment*. New York: Princeton Architectural Press, 2008.

Brownell, Blaine. *Transmaterial 3 : a catalog of materials that redefine our physical environment*. New York, N.Y: Princeton Architectural Press, 2010.

Republic of Iraq Ministry of Housing. *Iraq National Housing Policy*. UN Habitat. 2010. Web. 2012

Unknown. *Internally displaced population*. Internal Displacement Monitoring Centre. 2011. Web. 2012.

Republic of Iraq Ministry of Housing and Construction. *Iraq Housing Market Study*. Rep. PADCO, 2006. Web. 2012.

Unknown. *Iraq Eyes OPEC Top Spot, Seeks India Pact*. United Press International. 2011. Web. 2012.

Unknown. *Shell Plans Venture to Expand Presence in Iraq*. The National. 2011. Web. 2012.

David, Morgan. *Iraq Petrochemicals & Plastics Sector*. Global Arab Network. 2009. Web. 2012.

© 2013 David Nicholas COSTANZA. All rights reserved.